

DA425HA: 99900682: 19980223



Model DA425HA Air Compressor

(Dual Cooler - 10GPM)

(Replaces Model 1143)



IOWA MOLD TOOLING CO., INC.

BOX 189, 500 HWY 18 WEST, GARNER, IA 50438

TEL: 515-923-3711

TECHNICAL SUPPORT FAX: 515-923-2424

MANUAL PART NUMBER 99900682

PRECAUTIONS

Read before operating your compressor!



71393886



DANGER

EXPLODING TANK WILL CAUSE DEATH, SERIOUS INJURY OR PROPERTY DAMAGE

- Drain air tank after each use to prevent moisture build-up and corrosion which leads to tank failure.
- Assure that tank and compressor relief valves work properly, and are at correct pressure settings.
- **DO NOT** modify or repair air tank.
- **NEVER** drive vehicle with pressure in air tank.



Failure to follow operating and maintenance procedures as outlined in this manual could result in equipment damage, personal injury or death. Follow all maintenance procedures and intervals.



Do not use air from this compressor for breathing or food processing. Air from this compressor will cause severe injury or death if used for breathing or food processing.



Maintenance must be performed only by trained and qualified personnel, using correct tools, specified torques and approved replacement parts.

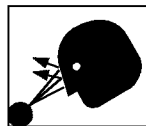

Hot oil under pressure can cause severe injury or death. Shut down, let cool and relieve pressure in compressor before servicing.



All electrical components and cable wiring must be installed and grounded in accordance with NFPA, national electrical codes and applicable state and local codes.



Do not overfill the compressor with oil. Use correct quantity of manufacturer's lubricant. Repair leaks and clean spills immediately.



Before removing guards or servicing the compressor, disconnect all power supplies. Display warning signs and lock out electrical circuits.



Compressors generate high temperatures. Do not touch or otherwise come in contact with hot surfaces. Doing so can cause severe personal injury.



All guards must be in position and secure before and during operation.

TABLE OF CONTENTS

PARA	TITLE	PAGE
GENERAL INFORMATION		
	INTRODUCTION	1-1
	ORDERING INFORMATION	1-1
Section 1. SPECIFICATIONS		
1-1.	GENERAL	1-1
1-2.	SPECIFICATIONS	1-1
Section 2. INSTALLATION		
2-1.	GENERAL	2-1
2-2.	PTO AND PUMP INSTALLATION	2-1
2-2-1.	PTO INSTALLATION	2-1
2-2-2.	DRIVELINE AND PUMP INSTALLATION	2-2
2-3.	COMPRESSOR INSTALLATION	2-2
Section 3. OPERATION		
3-1.	GENERAL	3-1
3-2.	OPERATION	3-1
Section 4. MAINTENANCE & PARTS		
4-1.	GENERAL	4-1
Section 5. REPAIR		
5-1.	GENERAL	5-1
5-2.	PISTON RING REPLACEMENT	5-1
5-3.	OIL PUMP REPLACEMENT	5-2
5-4.	CRANKSHAFT AND BEARING REPLACEMENT	5-2
5-5.	CLUTCH REPLACEMENT	5-3
5-6.	TROUBLESHOOTING	5-4
Section 6. RELAY BOARD OPERATION		
6-1.	INTRODUCTION	6-1
6-2.	OPERATION	6-1
6-2-1.	IGNITION "ON"	6-1
6-2-2.	REMOTE STARTING THE VEHICLE	6-1
6-2-3.	REMOTE ENGINE STOP	6-1
6-2-4.	REMOTE ENGINE SPEED (FROM CRANE)	6-3
6-2-5.	COMPRESSOR ENGINE SPEED CONTROL(COMPRESSOR ONLY)	6-3
6-2-6.	ENGINE SPEED CONTROL(CRANE&COMPRESSOR USED SIMULTANEOUSLY)	6-3
6-3.	INSTALLATION	6-7

LIST OF ILLUSTRATIONS

FIGURE	TITLE	PART NUMBER	PAGE
B-1.	PTO INSTALLATION		2-1
B-2.	DRIVELINE AND PUMP INSTALLATION		2-2
B-3.	COMPRESSOR MOUNTING HOLE DIMENSIONS		2-2
	ROUTINE MAINTENANCE CHECKLIST		4-1
	MOUNTING HARDWARE KIT	51712642	4-2
	OPTION-RELAY BOARD KIT	51711092	4-3
	COMPRESSOR ASSEMBLY WITH ENCLOSURE	51709571	4-3
	DA425 AIR COMPRESSOR	51707079	4-5
	OPTIONAL HYDRAULIC INSTALLATION KIT	91707052	4-8
	OPTIONAL INSTALLATION KIT WITH CRANE	93710121	4-8
	OPTION-AIR FILTER KIT	95709998	4-9
	DRIVELINE MOUNTING OPTION	31701761	4-10
	REPAIR KITS		4-10
	CRANKCASE & CRANKSHAFT ASM	51705811	4-11
	COMPRESSOR ASSEMBLY W/O COOLER	51712285	4-12
E-1.	PISTON RING ORIENTATION		5-1
E-2.	CYL HEAD TORQUE SEQUENCE		5-1
E-3.	BEARING HOUSING TORQUE SEQUENCE		5-3
E-4.	ROD ALIGNMENT		5-3
E-5.	TROUBLESHOOTING CHART		5-4
F-1.	BOTTOM VIEW OF RELAY		6-1
F-2.	INTERNAL WIRING		6-1
F-3.	RELAY BOARD-COMPONENTS & WIRING		6-2
F-4.	IGNITION "ON"		6-4
F-5.	REMOTE CONTROL HANDLE-TYPICAL		6-4
F-6.	REMOTE STARTING OF VEHICLE-IGNITION "ON"		6-5
F-7.	SPEED CONTROL-COMPRESSOR ONLY		6-6
F-8.	RELAY BOARD (77041378) WIRING INSTRUCTIONS		6-7

GENERAL INFORMATION

INTRODUCTION

This manual provides information on the installation, operation and repair of the IMT Model DA425HA Hydraulic Air Compressor.

Three means are used throughout this manual to gain the attention of operating and service personnel. They are NOTES, CAUTIONS and WARNINGS and are defined as follows:

NOTE

A NOTE IS USED TO EITHER CONVEY ADDITIONAL INFORMATION OR TO PROVIDE FURTHER EMPHASIS FOR A PREVIOUS POINT.

CAUTION

A CAUTION IS USED WHEN THERE IS THE STRONG POSSIBILITY OF DAMAGE TO THE EQUIPMENT OR PREMATURE EQUIPMENT FAILURE.

WARNING

A WARNING IS USED WHEN THERE IS THE POTENTIAL FOR PERSONAL INJURY OR DEATH.

Operate this equipment with respect and service it regularly for a safer working environment and longer equipment life.

ORDERING INFORMATION

When placing orders or requesting assistance, refer to the information below:

TO BE COMPLETED BY DEALER	
CHASSIS INFORMATION	
TRANSMISSION MAKE:	MODEL:
PTO NUMBER:	PTO %:
COMPRESSOR AND HYDRAULIC PUMP INFORMATION	
COMPRESSOR MODEL:	SERIAL NUMBER:
PUMP MAKE:	MODEL:
RESERVOIR CAPACITY:	ENGINE RPM:

SECTION 1. SPECIFICATIONS

1-1. GENERAL

The IMT DA425HA air compressor is a single stage, air cooled, 4-cylinder, pressure lubricated, hydraulically driven unit, with a delivery rate of 25 CFM at 100 PSI.

CAUTION

OPERATING THE COMPRESSOR AT PRESSURES ABOVE 150 PSI WILL SHORTEN THE SERVICE LIFE AND VOID THE WARRANTY.

1-2. SPECIFICATIONS

Power Source	Hydraulic Motor
Bore	2-5/8"
Stroke	2"
Cylinder Configuration	V4
Dimensions	26"L x 18"H* x 18"W
Displacement	37.5 CFM*
Delivery	25 CFM*
Cooling	Air
Fan Diameter	14"
Operating Speed	1400 RPM maximum
Lubrication	Oil Pump
Oil Capacity	1-1/3 qts
Weight	200 lbs.
Reservoir requirement	12 Gallon minimum

* @ 1400 RPM - 100 PSI

SECTION 2. INSTALLATION

2-1. GENERAL

This section pertains to the installation of the IMT DA425HA compressor, PTO and pump. The instructions are intended as a guide to assist you with your particular installation. These instructions will provide only general information.

2-2. PTO AND PUMP INSTALLATION

The pump may either be installed directly on the PTO (see Figure B-1) or, as an optional method, it may be driven by a driveline (see Figure B-2).

2-2-1. PTO INSTALLATION

Power take-off manufacturers provide specific installation instructions for their products. Those instructions should be followed when installing a PTO. Some trucks may require modification of the transmission cross-member to provide clearance and the exhaust pipe may need modification. Check with the PTO manufacturer's representative for specific instructions regarding your particular make, model and year of vehicle. The following instructions are a guide in this application.

1. If the vehicle is new, drain the transmission oil into a clean container for reuse. If the vehicle is used, drain and dispose of the transmission oil properly.

2. Temporarily install the PTO with the proper gaskets and only two studs. Snug the PTO down and check the backlash for maximum allowance of 1/32" to 1/16". If the backlash is excessive, remove gaskets and check backlash again until it is corrected.

3. Remove the PTO and apply Permatex® to the gaskets. If the holes for the studs are tapped through the transmission housing, apply Permatex to the studs and tighten them down. Make certain that the studs do not interfere with the transmission gears.

CAUTION

AVOID CONTACT OF PERMATEX® WITH TRANSMISSION FLUID.

4. Install the PTO and gaskets. Torque the nuts to 30 - 35 ft-lbs (4.14 - 4.84 kg-m) for a 6-bolt PTO and 45 - 50 ft-lbs (6.22 - 6.91 kg-m) for 8-bolt PTO's. Recheck the backlash.

5. Install the shifter cable to suit conditions. Always allow for a slight overshift on lever or knob to ensure the PTO is fully disengaged.

CAUTION

IT IS IMPORTANT THAT ADEQUATE SPACE BE ALLOWED FOR FULL ENGAGEMENT OF THE PTO. MODIFY THE EXHAUST OR OTHER OBSTRUCTIONS AS NEEDED.

CAUTION

AVOID SHARP BENDS IN THE SHIFTER CABLE. ALL BENDS SHOULD HAVE AT LEAST A 6" RADIUS. TIGHTER BENDS WILL CAUSE DIFFICULT OPERATION OF THE SHIFTER KNOB.

6. Replace the transmission oil. If the PTO is located below the transmission oil level, an additional quantity of oil will be required.

7. Start the engine, engage the PTO and allow it to run for 5 - 10 minutes. Check for leaks, unusual noise and proper operation.

8. Retorque the mounting bolts.

® REGISTERED TRADEMARK OF PERMATEx CO., INC., KANSAS CITY, KANSAS

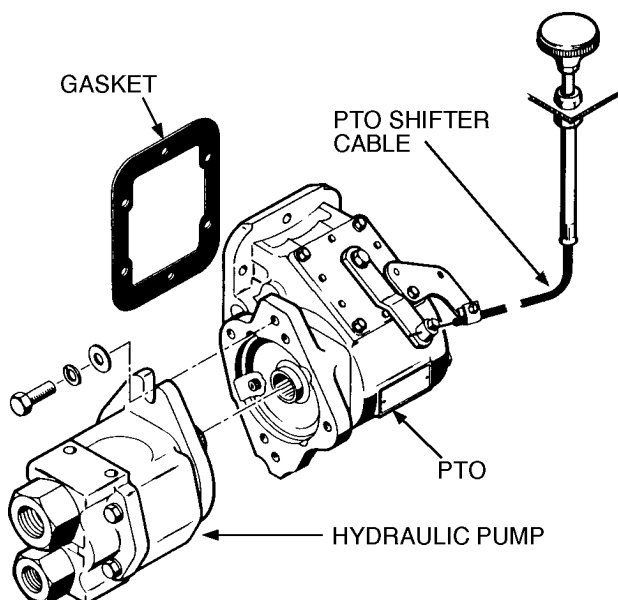

FIGURE B-1. PTO INSTALLATION

2-2-2. DRIVELINE AND PUMP INSTALLATION

The pump may be driven as shown in Figure B-2 as an optional method to the one shown in Figure B-1. The following steps are a guide in this application.

1. Install the PTO (refer to Paragraph 2-2-1).
2. Loosely bolt the pump mounting bracket (A) to the adjustable bracket (B) in Figure B-2.
3. Bolt the adjustable bracket to the frame at a point that will not exceed 48" (122cm) from the PTO and will not cause a joint angle greater than 3°.
4. Check the pump rotation and install pump, pump end yoke and PTO end yoke.
5. Size, cut and weld the driveline to the necessary length. Ensure driveline balance. Allow 1" (2.54cm) extra for PTO end yoke.
6. Install driveline, lock set screws and lubricate U-joints.
7. Ensure all mounting bolts are tight.

WARNING

THE INSTALLER OF THE DRIVELINE MUST INSPECT THE FINAL POSITION OF THE DRIVELINE TO DETERMINE WHETHER ITS LOCATION PROVIDES SUFFICIENT PROTECTION TO AN OPERATOR, OR OTHER PERSONNEL, FROM HAZARDS ASSOCIATED WITH A ROTATING DRIVELINE. IF PROTECTION IS INSUFFICIENT, THE INSTALLATION OF A GUARD IS REQUIRED. IF YOU ARE UNSURE OF METHODS TO GUARD A ROTATING DRIVELINE, CALL IOWA MOLD TOOLING CO., INC. FOR INSTRUCTIONS. FAILURE TO DO SO MAY RESULT IN SERIOUS INJURY OR DEATH.



2-3. COMPRESSOR INSTALLATION

1. Prepare the mounting location of the compressor by locating and drilling four (4) holes, 7/16" diameter, as shown in Figure B-3.

2. Position the rubber bumpers on these holes and lift the compressor into place.
3. Using the four (4) 3/8-16x2-1/2" cap screws and 3/8" wrought washers, secure the compressor in place by inserting the cap screws from below the mounting surface as shown in Figure D-1.
4. Electrical Connections:
 - A. Connect the black wire to the vehicle frame or other suitable ground.
 - B. Mount the single throw toggle switch in a convenient location. Connect the red wire from the compressor switch. Connect the other terminal of the switch to the fuse holder and then to a 12-volt power supply as shown in Figure D-1.
 - C. The blue wire is to be connected to the speed control through a relay.

CAUTION

DAMAGE MAY OCCUR IF THE COMPRESSOR IS NOT CONNECTED TO A SPEED CONTROL.

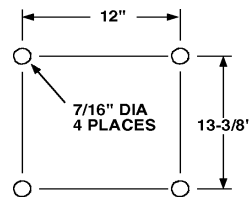

FIGURE B-3. MOUNTING HOLE DIMENSIONS

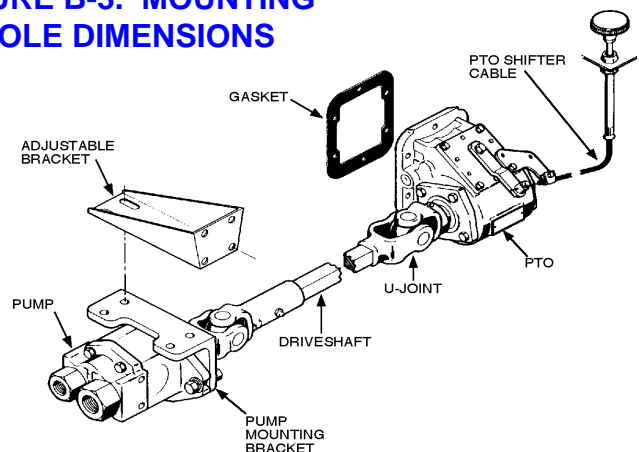

FIGURE B-2. DRIVELINE & PUMP INSTALLATION

SECTION 3. OPERATION

3-1. GENERAL

Each compressor is bench tested under load at the factory to ensure proper break-in and operation. While it is not necessary to follow any break-in procedure, the following checks should be made before putting the unit into service, as well as, periodically during use.

1. Before start-up:
 - A. Check the oil level in the compressor crankcase with the dipstick on the unit. If oil is needed, use only IMT's synthetic compressor oil.

 - B. Check the air intake filters on each head to make certain that they are clean and unobstructed. Dirty filters are a possible cause of reduced air output.

2. With the compressor engaged:

Adjust engine speed to ensure that compressor speed does not exceed 1400 RPM (max) under load.

3-2. OPERATION

To use the compressor, start the vehicle engine and engage the compressor by operating the compressor switch. The system will now function automatically. It will engage the compressor clutch when the air pressure is below 120 psi, and disengage when the air pressure reaches 150 psi.

NOTE

ON UNITS WITH MANUAL ENGINE SPEED CONTROL, THE ENGINE RPM WILL INCREASE WHEN THE COMPRESSOR CLUTCH DISENGAGES.

CAUTION

OPERATING THIS UNIT IN EXCESS OF 1400 RPM, WILL VOID THE WARRANTY, AND WILL SHORTEN THE NORMAL SERVICE LIFE OF THE COMPRESSOR.

Section 4. MAINTENANCE & PARTS

4-1. GENERAL

The following table is a list of routine maintenance items, including service intervals. It also includes a parts list and assembly drawing of the compressor.

MAINTENANCE OPERATION	SERVICE INTERVALS			
	DAILY	WEEKLY	250/3	500/6
AIR INTAKE - INSPECT AND CLEAN				
CRANKCASE OIL LEVEL - CHECK, ADD IF NEEDED				
CRANKCASE OIL - CHANGE (SEE NOTE 1)				
CHECK CYLINDER HEAD BOLT TORQUE (SEE NOTE 2)				
COOLING VANES (FINS) - CLEAN				
SAFETY VALVES - CHECK OPERATION				
SAFETY VALVES - CLEAN				
BELT TENSION - CHECK				
ELECTRIC CLUTCH - CHECK OPERATION				
AIR RECEIVER - DRAIN CONDENSATION				
RECEIVER SAFETY VALVES - CHECK OPERATION				
TIGHTEN AND CHECK ALL VALVES				
CHECK ALL ELECTRICAL CONNECTIONS				
CHECK FITTINGS AND AIR LINES FOR LEAKS				
INSPECT CHECK VALVES FOR PROPER OPERATION				
INSPECT CHECK VALVES FOR CARBON BUILDUP				

Service intervals are listed as hours/months, whichever occurs first.

Use only IMT's synthetic compressor oil. The use of any other oil causes excessive carbon buildup, and will void the warranty on the compressor.

NOTE 1. Under normal operating conditions, oil changes are required every 3 months. When operating in a dirty environment, change the oil more frequently as your particular operating conditions dictate. Oil capacity is 1-1/3 quarts.

NOTE 2. Cylinder head bolt torque MUST be checked after the initial 8-10 hours of operation. The compressor must be cold (room temperature) before retorquing of bolts. Torque bolts to 180 in-lbs plus or minus 10 in-lbs.

FIGURE D-1. ROUTINE MAINTENANCE CHECKLIST

MOUNTING HARDWARE KIT (51712642)

ITEM	PART NO.	DESCRIPTION	QTY
1.	51709571	COMPRESSOR 10GPM(see dwg)	1REF
	51709573	COMPRESSOR 8GPM (see dwg)	1REF
2.	60110673	FILTER BRACKET	2
3.	72060023	CAP SCR 5/16-18X3/4 HHGR5	4
4.	73052012	FILTER-HYD SUCTION 100-MESH	1
5.	72060050	CAP SCR 3/8-16X2 HHGR5	4
7.	72063003	WASHER 3/8 WRT	4
8.	73052000	FILTER 10-MICRON	1
9.	76391527	RUBBER BUMPER	4

10.	77040048	BUTT CONNECTOR 16-14GA	2
11.	77040000	TERMINAL SPD #10 16-14GA	2
12.	77041345	TOGGLE SWITCH	1
13.	77041056	IN-LINE FUSE 20AMP	1
14.	89044233	CABLE 14GA BRN	24"
15.	89044371	CABLE 14GA 3WIRE	25"
16.	77040052	TERMINAL RING 3/8 12-10GA	1
17.	89044274	WIRE 14GA BLK	24"
18.	60103535	SWITCH BRACKET	1
19.	77044237	BULLET PLUG 18-14GA	3
20.	77044238	BULLET PLUG 18-14GA	3

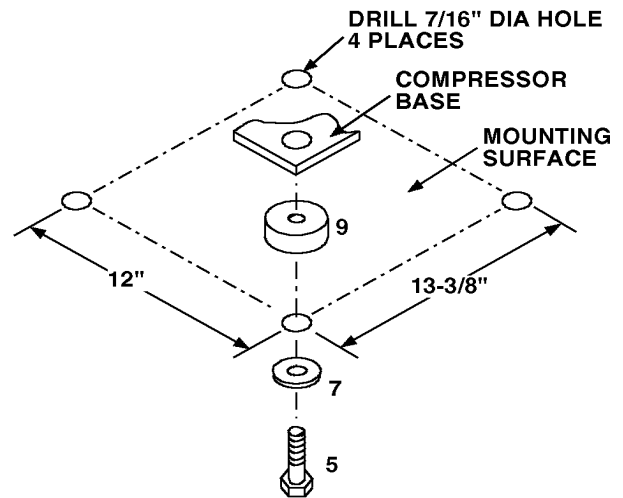
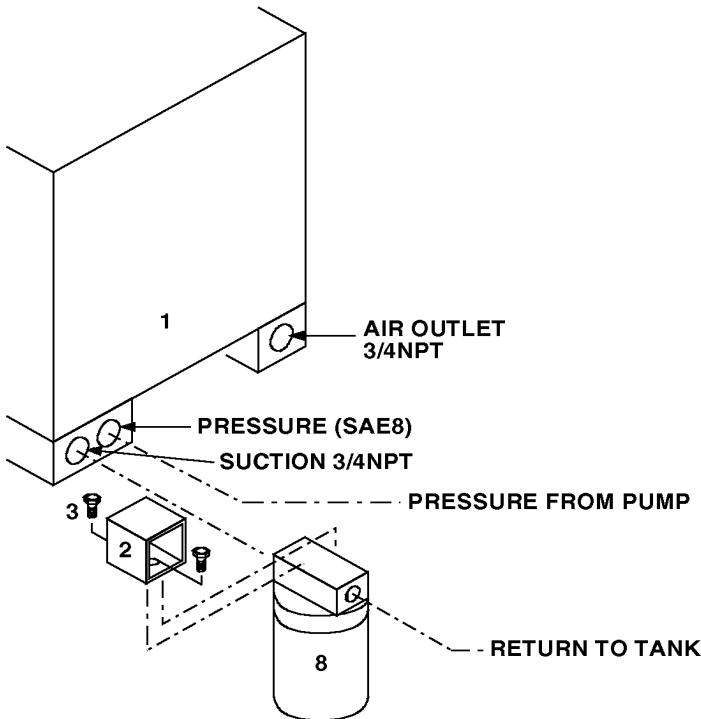
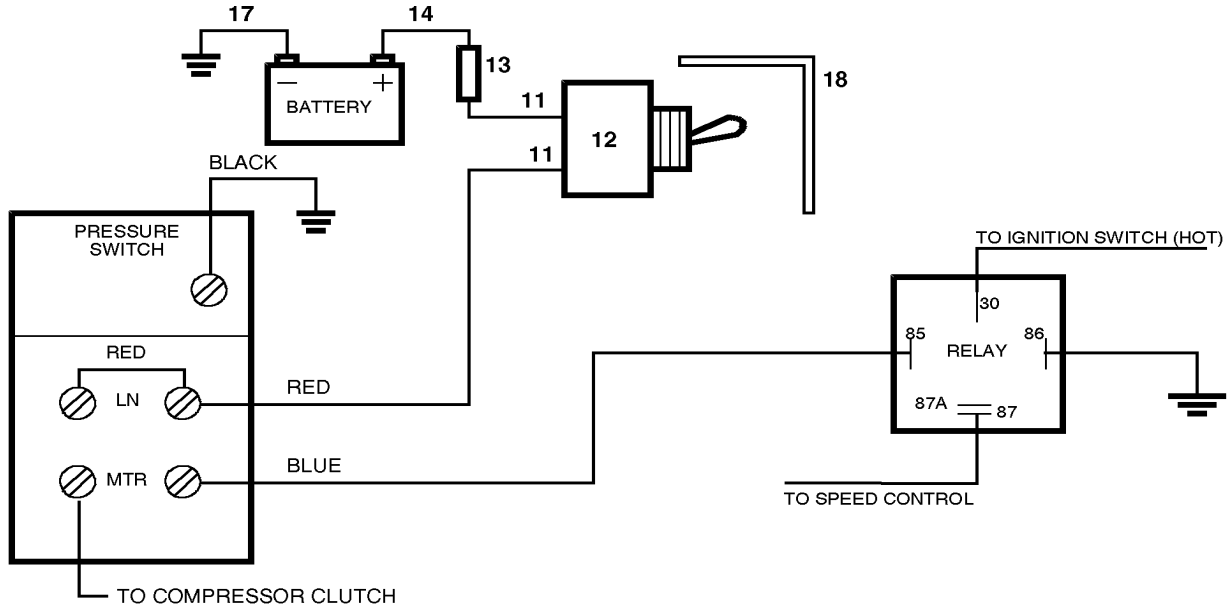

OPTION-RELAY BOARD KIT (51711092)

ITEM	PART NO.	DESCRIPTION	QTY
	77041378	RELAY BOARD	1
	77041383	RELAY	8
	77041100	FUSE 20AMP	1
	72601576	SHT MTL SCR #10X1-1/2	4
	99900661	INSTALLATION INSTRUCTIONS	1

CONTINUED ON FOLLOWING PAGE

DA425HA10 COMPRESSOR ASM W/ENCLOSURE (51709571-1)

ITEM	PART NO.	DESCRIPTION	QTY	ITEM	PART NO.	DESCRIPTION	QTY
1.	52709542	REAR COOLER MTG PLATE	1	48.	72532360	ADAPTER 1-1/16MSTR 3/4MJIC	1
3.	72053535	STREET ELBOW 3/4NPT 45°	3	49.	72533116	ELBOW 3/4MPT 3/4BARB	2
4.	72053645	ADAPTER 3/4MP 3/4FPT SWVL	1	50.	72533117	BARB NIPPLE	1
5.	72060046	CAP SCR 3/8-16X1 HHGR5	5	51.	73054583	RELIEF VALVE	1
6.	72066000	HOSE CLAMP 1/2-1 1/4 #12	10	52.	60350006	HOSE 3/4 100R4 X 4-1/2	1
7.	60110273	CLUTCH-SGL GROOVE	1	53.	52706924	MOTOR MOUNT	1
8.	72532832	HOSE FITTING 3/4NPT 3/4HOSE	4	54.	60015015	FAN	1
9.	77041369	PRESSURE SWITCH	1REF	55.	60025506	CLUTCH ADAPTER	1
11.	89392349	HOSE 3/4 300PSI X 7	1	56.	60110379	MOTOR ADAPTER	1
12.	52707036	BASE	1	57.	70143145	SPIDER	1
13.	70034293	PLUG 3/4NPT	2	58.	72060030	CAP SCR 5/16-18X2-1/4 HHGR5	4
14.	70394268	PLUG 1/2STR	1	59.	72053556	ST ELBOW 3/4NPT 90° (part of 62)	1REF
15.	72053241	PIPE PLUG 1/4NPT HOLHEX	1	60.	72062038	NUT 7/16-20 HEX (PART OF 64)	1REF
16.	72053243	PIPE PLUG 1/2NPT HOLHEX	1	61.	72062103	NUT 3/8-16 LOCK	6
17.	72060025	CAP SCR 5/16-18X1 HHGR5	12	62.	51713112	PRESSURE SWITCH ASM	
18.	72063050	WASHER 5/16 LOCK	8		(INCL:3,6,8,9,34,36,38,40,42,44,46,59,66,76-79)		1
19.	72063002	WASHER 5/16 WRT	20	64.	73051505	MOTOR 10GPM	1
20.	76391173	GROMMET	1	65.	52713084	FRONT ENCLOSURE PANEL	2
21.	76393038	GROMMET 7/16	1	66.	72532952	BRASS INSERT	2REF
22.	51707079	COMPRESSOR (SEE DRAWING)	1	67.	76392227	GROMMET	1
23.	70039124	TAG-SYNTHETIC OIL	1	68.	72661301	POP RIVET .156	2
24.	70143495	BREATHER CAP	1REF	69.	70029117	IDENT PLACARD	1
25.	72053713	ELBOW 3/4MPT 3/4FPT 90°	1	70.	89086089	SYNTHETIC OIL	2QTS
26.	72053559	REDUCER BUSHING 1-3/4NPT	1	71.	70143144	OIL COOLER	2
27.	72053819	PIPE CAP 3/8NPT	1	73.	72601652	MACH SCR 1/4-20X3/4 TRHORXSS	18
28.	72060048	CAP SCR 3/8-16X1-1/2 HHGR5	10	74.	72062109	NUT 5/16-18 LOCK	8
29.	72063051	WASHER 3/8 LOCK	9	76.	51712189	CHECK VALVE ASM	1REF
30.	72531856	REDUCER COUPLING 3/4-1/2NPT	1REF	77.	89392349	HOSE 3/4 300PSI X9	1REF
31.	72532555	HOSE FITTING 3/8 3/8	2	78.	51711410	WIRE ASM 14GA BLK 6"	1REF
32.	89392426	HOSE 3/8 200PSI X 10	1	79.	77044467	3/16 BULLET RECEPT 16-14GA	1REF
33.	52713082	FAN SHROUD	1	80.	60119135	TOP ENCLOSURE	181.
34.	89044232	WIRE 14GA RED X 3"	1	60119137	PANEL-RH SIDE	1	
35.	60350008	HOSE 3/4 100R4 X 31"	1	82.	60119138	PANEL-LH SIDE	1
36.	72531130	ELBOW 1/2STR 90°	1REF	83.	76393107	O-RING (PART OF 76)	1REF
37.	60350007	HOSE 3/4 100R4 X 17	1	84.	60106933	CAP (PART OF 76)	1REF
38.	89044371	CABLE 14GA 3WIRE	24"	85.	70029468	SHIM (PART OF 76)	1REF
39.	72063003	WASHER 3/8 WRT	10	86.	70073017	O-RING (PART OF 76)	1REF
40.	72053720	ADAPTER 1/4MPT 1/8MPT	1REF	87.	76393085	O-RING (PART OF 76)	1REF
41.	70143157	TUBE ASM	1	88.	70029593	INSERT (PART OF 76)	1REF
42.	77040050	TERMINAL-SPD #10 STUD	6REF	89.	72066426	BALL (PART OF 76)	1REF
43.	72053458	BARB NIPPLE 3/4NPT 3/4BARB	3	90.	72053404	PLUG (PART OF 76)	1REF
44.	89034176	TUBING 1/4	1REF	91.	72053405	PLUG (PART OF 76)	1REF
45.	72053559	REDUCER BUSHING 1-3/4NPT	4	92.	89044274	WIRE 14GA BLK (PART OF 62)	1REF
46.	72531042	ELBOW 1/8-1/4NPT 90° BRASS	1REF	93.	52712190	CHECK VALVE (PART OF 76)	1REF
47.	72532358	ADAPTER 3/4MSTR 3/4MJIC	1				

DA425HA10 COMPRESSOR ASM W/ENCLOSURE (51709571-2)

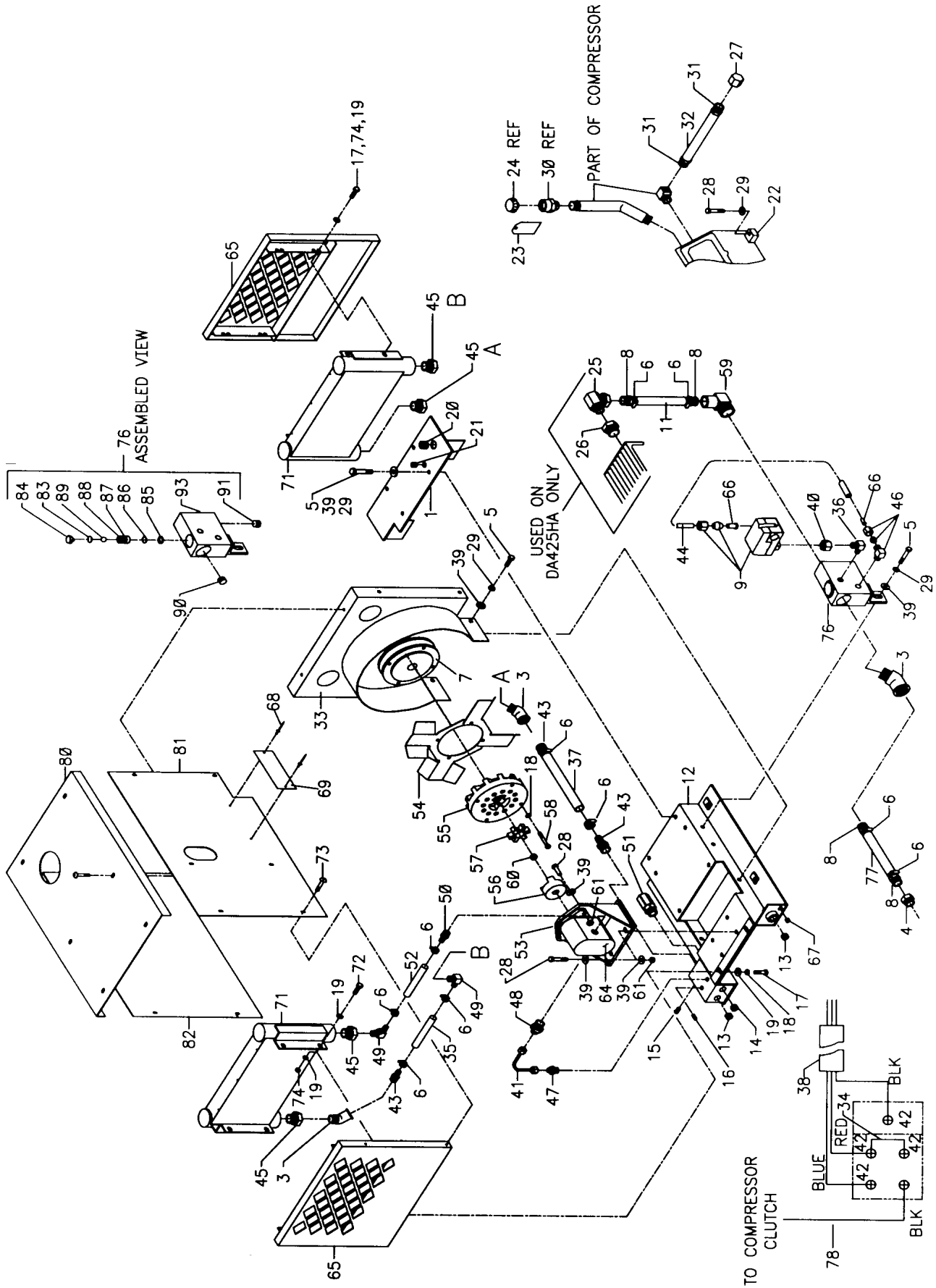

**DA425HA AIR COMPRESSOR
(51707079-1)**

CONTINUED ON FOLLOWING PAGE

ITEM	PART NO.	DESCRIPTION	QTY	ITEM	PART NO.	DESCRIPTION	QTY
1.	60025012	CRANKCASE (PART OF 83)	1REF	54.	60101269	OIL PUMP COLLAR (PART OF 84)	1REF
2.	60025010	CYLINDER BLOCK	2	55.	72066307	ROLL PIN .16X.44 (PART OF 84)	1REF
3.	60025008	HEAD	2	56.	70055010	BEARING - CUP (PART OF 82)	1REF
4.	60025009	PULSATION TANK	1	57.	60025005	REAR BRG HSG (PART OF 82)	1REF
5.	70073031	REED VALVE ASM	2	58.	70014583	SPRING	1
6.	73731843	DIPSTICK ASM	1	59.	60101505	PLUNGER TRANSFER BUSHING	1
7.	70143153	DIPSTICK TUBE	1	60.	70051006	OIL PUMP	1
8.	60120238	OIL SCREEN TUBE (PART OF 83)	1REF	61.	60025006	REAR BRG HSG COVER	1
9.	60120289	OIL SCREEN (PART OF 83)	1REF	63.	72053411	PIPE PLUG 1/8NPT SQHD	2
10.	72066008	OIL SCREEN CLAMP (PART OF 83)	1REF	64.	72060731	CAP SCR 5/16-18X3/4 SH	
11.	60101507	OIL FILL BREATHER PIPE	1		(PART OF 83)	5REF	
12.	70143495	BREATHER ASM (INCL:89,90)	1	65.	72060731	CAP SCR 5/16-18X3/4 SH	4
13.	76393085	O-RING (PART OF 77)	1REF	66.	51029296	CONNECTING ROD ASM	4
14.	72053403	PLUG 3/8NPT SH (PART OF 83)	1REF	67.	70029062	PISTON (PART OF 88)	4REF
15.	72053413	PLUG 3/8NPT SQHD(PART OF 83)	1REF	68.	70014627	PISTON PIN (PART OF 88)	4REF
16.	70039300	DECAL - COMPRESSOR PATENT	1	69.	72066018	RETAINING RING(PART OF 88)	8REF
17.	70014626	CLIP-AIR FILTER	8	70.	70014600	OIL RING (PART OF 87)	4REF
18.	76039141	FILTER-FOAM	2	71.	70014599	COMPRESSION RING (PART OF 87)	8REF
19.	73054026	DRAIN COCK VALVE 1/8	1	73.	76039093	PUMP COVER GASKET	1
20.	72053406	PIPE PLUG 1"NPT SH	1	74.	76039112	FRT BRG HSG GSKT(PART OF 83)	2 REF
21.	72060032	CAP SCR 5/16-18X2-3/4 HH GR5	12	75.	72063050	WASHER 5/16 LOCK	1
22.	72060062	CAP SCR 7/16-14X1 HH GR5	4	76.	72053404	PIPE PLUG 1/2 SH	1
23.	72060025	CAP SCR 5/16-18X1 HH GR5	12	81.	51705709	FRT BRG HSG ASM(INCL:47,49)	
24.	72063001	WASHER 1/4 WRT	12		(PART OF 83)	1REF	
25.	70024122	WASHER .33X.50X.03	12	82.	51705710	REAR BRG HSG ASM(INCL:56,57)	
26.	72063052	WASHER 7/16 LOCK	4		(PART OF 83)	1REF	
27.	72053590	STREET ELBOW 3/8 90°	1	83.	51705811	CRANKCASE /CRANKSHAFT ASM	1
28.	7Q072212	O-RING	2	84.	51704321	CRANKSHAFT(INCL:50,51,53-55)	1REF
29.	76039113	VALVE COVER GASKET	2	85.	72063050	WASHER 5/16 LOCK (PART OF 83)	5 REF
30.	76039114	CYL BLOCK TOP GASKET	2	86.	72060025	CAP SCR 5/16-18X1 HHGR5	
31.	76039111	CYL BLOCK BOTTOM GASKET	2		(PART OF 83)	5REF	
32.	72531856	REDUCER COUPLING 3/4-1/2NPT	1	87.	51014947	RING SET-THREE (INCL:70,71)	1
33.	76393802	FILTER SCREEN	4	88.	51029285	PISTON ASM	4
38.	72053558	PIPE NIPPLE 3/4NPT X 2	1	91.	70039124	DECAL-OIL FILL	1
39.	72053376	REDUCER BUSHING 1X3/4	1	92.		PULLEY	1REF
45.	72661487	DRIVE PIN	1	93.	77044419	CLUTCH FIELD	1
47.	76039119	SEAL (PART OF 81)	1REF	94.	72066537	J-CLIP	2
48.	60025007	FRT BRG HSG (PART OF 81)	1REF	95.	70732444	CLUTCH HARDWARE	1
49.	70055011	BEARING-CUP (PART OF 81)	1REF	101.	76039144	GASKET-REAR BRG .020	AR
50.	70055012	BRG-FRT CONE (PART OF 84)	1REF		76039143	GASKET-REAR BRG .015	AR
51.	60101271	CRANKSHAFT	1		76039094	GASKET-REAR BRG .010	AR
52.	72066267	KEY #6 WOODRUFF	1		76039092	GASKET-REAR BRG .006	AR
53.	70055009	CONE BEARING (PART OF 84)	1REF				

DA425HA AIR COMPRESSOR (51707079-2)

CONTINUED ON FOLLOWING PAGE

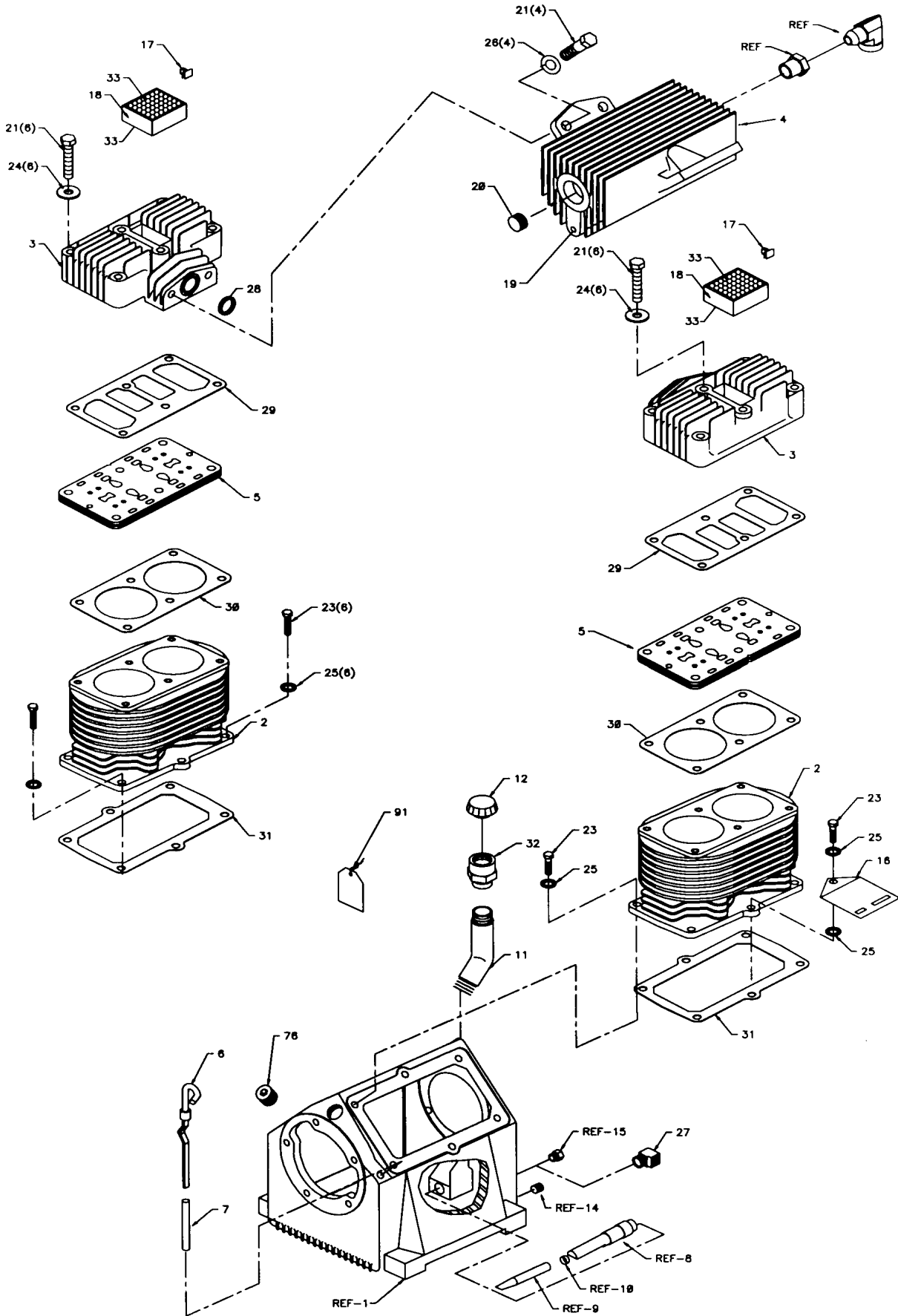

DA425HA AIR COMPRESSOR (51707079-3)

CONTINUED ON FOLLOWING PAGE

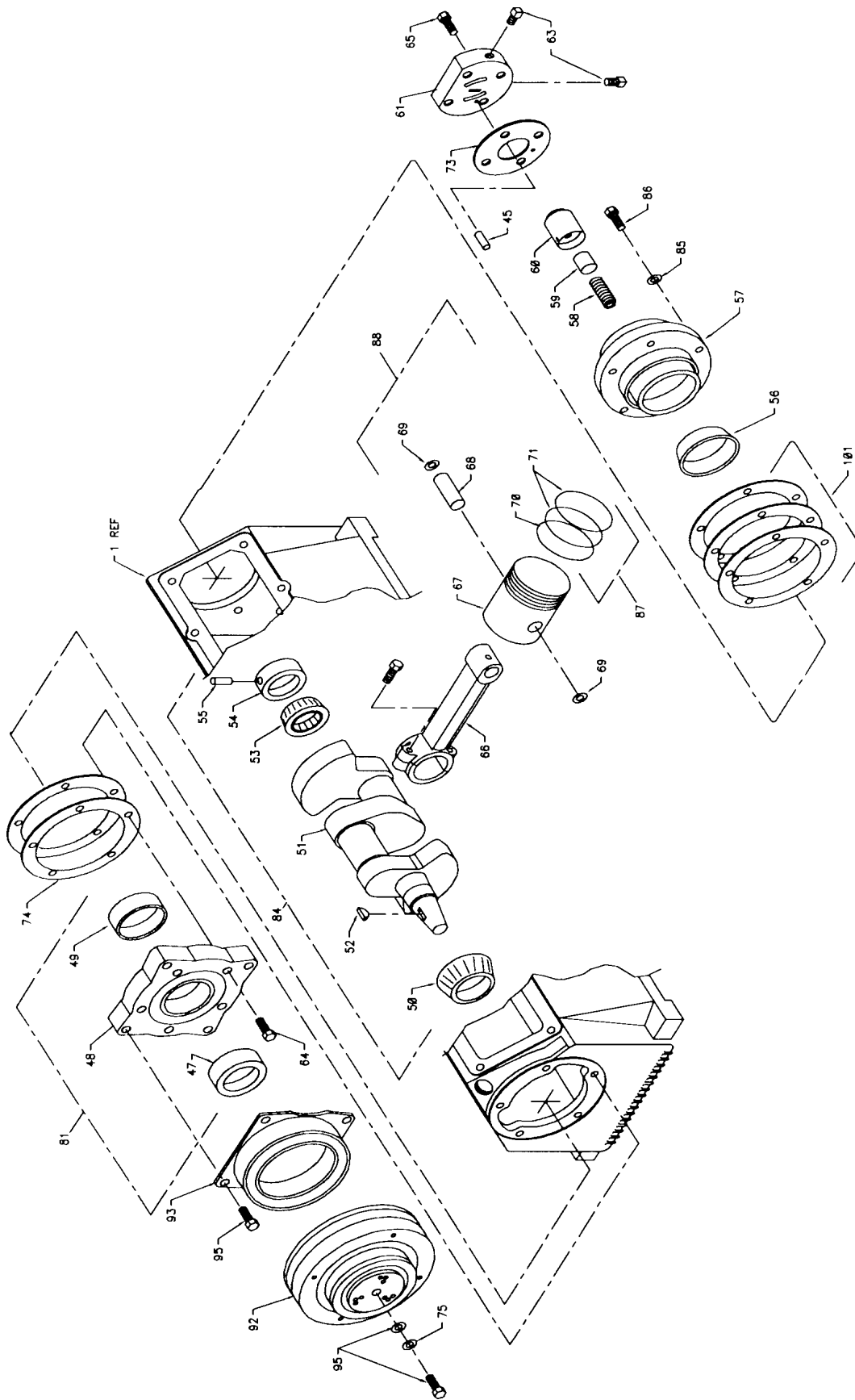

OPTIONAL HYDRAULIC INSTALLATION KIT (91707052)
OPTIONAL INSTALLATION KIT W/CRANE (93710121)

ITEM	PART NO.	DESCRIPTION	QTY	ITEM	PART NO.	DESCRIPTION	QTY
1.	72531427	ELBOW 3/4NPT #12MJIC	1	18.	72532712	BEAD NIPPLE #16MSTR 1" 45°	1
2.	72053676	ADAPTER 3/4MPT #12MJIC	6	20.	51706981	HOSE ASM 1/2X35	1
3.	51707317	HOSE ASM 3/4X100	1	21.	72532358	ADAPTER #8MSTR #8MJIC	1
4.	51703585	HOSE ASM 1/2X220 FF	1	22.	72532666	ELBOW #8MSTR #8MJIC XLG	1
5.	72053141	PIPE NIPPLE 3/4NPT X CLOSE	1	23.	51704576	HOSE ASM 3/4X72 FF	1
6.	73054129	GATE VALVE 3/4NPT	1	24.	51703945	HOSE ASM 3/4X17 FF	1
7.	73052000	RETURN FILTER 10-MICRON	1REF	25.	72532696	ELBOW #12MJIC #12FJIC SW	1
8.	72053180	REDUCER BUSHING 1-1/4 3/4	1	26.	73054685	ROTARY FLOW DIVIDER(part of 31)	1REF
9.	72532658	ELBOW #8MJIC #8FJIC(not shown)	2	27.	72532358	ADAPTER (PART OF 31)	3REF
10.	72053377	REDUCER BUSHING 1-1/4 1	3	28.	72532376	HOSE FITTING (PART OF 31)	4REF
11.	72431549	BARB NIPPLE 1MPT 1HOSE	3	29.	72532695	TEE MJIC (PART OF 31)	1REF
12.	89039481	HOSE 1" 100R4	14'	30.	51711092	KIT-RELAY BRD (PART OF 31)	1REF
13.	72066515	HOSE CLAMP 1" 2-BOLT	4	31.	93710121	INSTALLATION KIT W/CRANE (INCL:26-30)	1REF
14.	73054001	GATE VALVE 1NPT	1	32.	72532672	UNION-BULKHD #8JIC	1
15.	72053185	PIPE NIPPLE 1NPT X CLOSE	1	33.	72533371	UNION-BULKHD #12JIC	1
16.	51706446	HOSE ASM 3/4X35 FF	1				
17.	51709743	FILTER ASM 100-MESH	1REF				

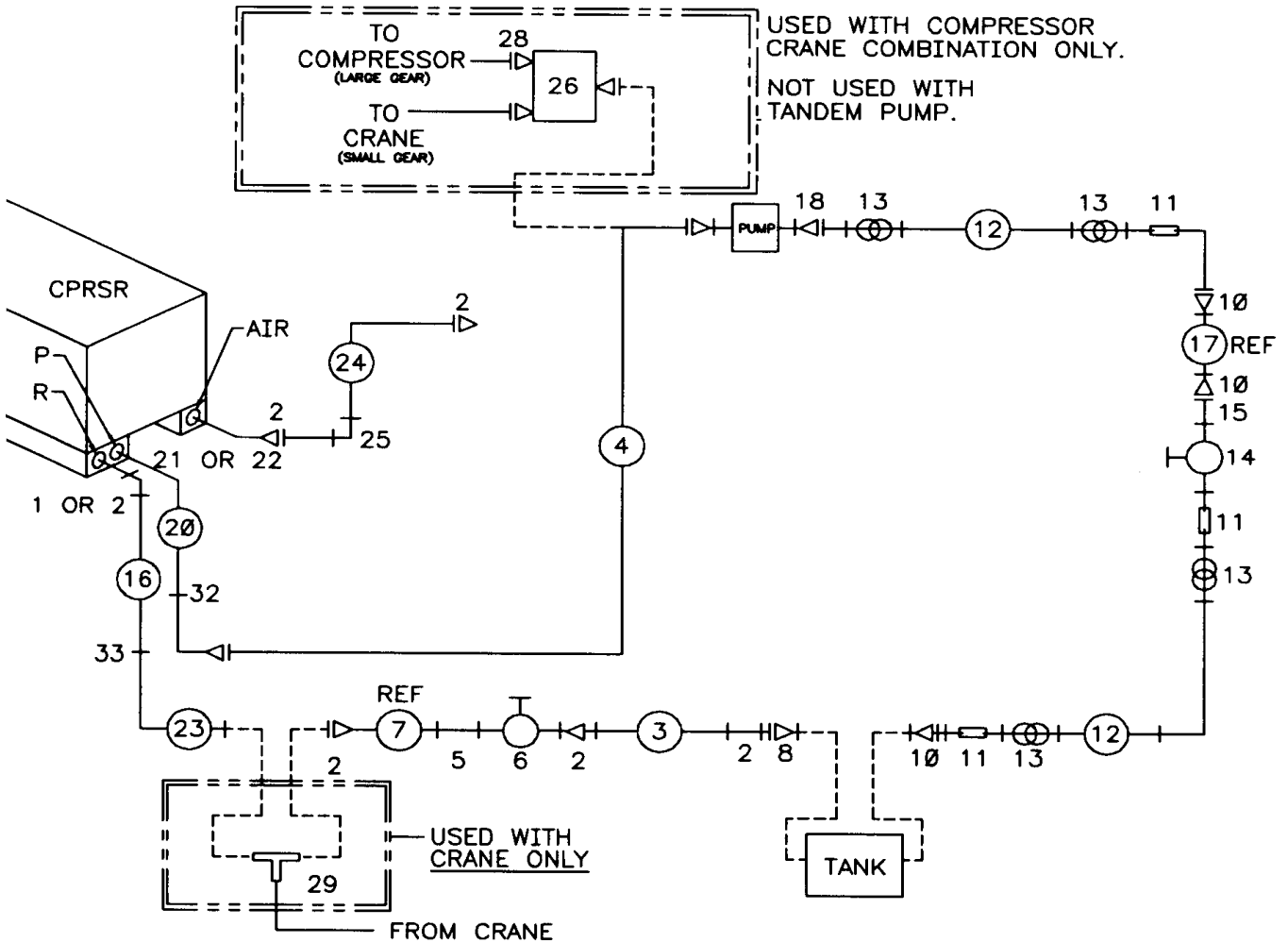

OPTION-AIR FILTER KIT (95709998)

ITEM	PART NO.	DESCRIPTION	QTY
1.	70029546	BREATHER MANIFOLD	2
2.	70048117	AIR FILTER CONE	2
3.	76392274	GASKET	2
4.	60106236	SLEEVE	4
5.	72063049	WASHER 1/4 LOCK	2
6.	72060270	CAP SCR 1/4-28X1/2 HHGR5	2
8.	72060035	CAP SCR 5/16-18X3-1/2 HHGR5	4
9.	72063001	WASHER 1/4 FLAT	4
10.	70024122	WASHER .33X.50X.03 COPPER	4

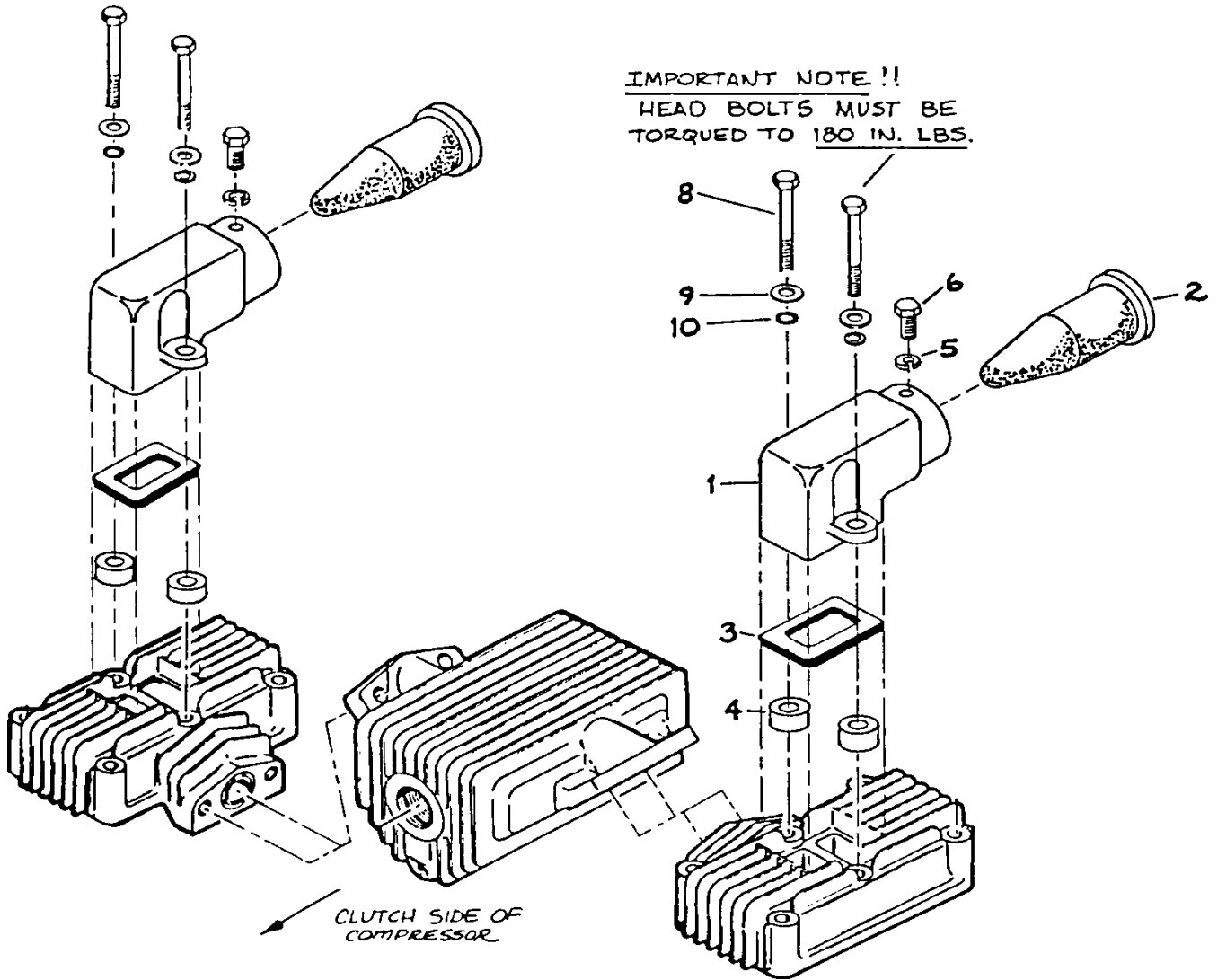

DRIVELINE MTG OPTION (31701761)

ITEM	PART NO.	DESCRIPTION	QTY
1.		POWER TAKE-OFF	REF
2.	70058146	END YOKE	1
3.	72060578	SET SCR 3/8-16X3/8 HH	1
4.	70058195	DRIVESHAFT ASM	1
5.	70058094	END YOKE	1
6.	60101988	MOUNTING BRACKET	1
7.	72063005	WASHER 1/2 WRT	4
8.	72060093	CAP SCR 1/2-13X1/2 HHGR5	4
9.	52703382	PUMP MOUNTING BRACKET	1
10.	72063053	WASHER 1/2 LOCK	8
11.	72062004	NUT 1/2-13 HEX	8
12.		HYDRAULIC PUMP	REF
13.	72060094	CAP SCR 1/2-13X1-3/4 HHGR5	4

WARNING

THE INSTALLER OF THE DRIVELINE MUST INSPECT THE FINAL POSITION OF THE DRIVELINE TO DETERMINE WHETHER ITS LOCATION PROVIDES SUFFICIENT PROTECTION TO AN OPERATOR, OR OTHER PERSONNEL, FROM HAZARDS ASSOCIATED WITH A ROTATING DRIVELINE. IF PROTECTION IS INSUFFICIENT, THE INSTALLATION OF A GUARD IS REQUIRED. IF YOU ARE UNSURE OF METHODS TO GUARD A ROTATING DRIVELINE, CALL IOWA MOLD TOOLING CO., INC. FOR INSTRUCTIONS. FAILURE TO DO SO MAY RESULT IN SERIOUS INJURY OR DEATH.

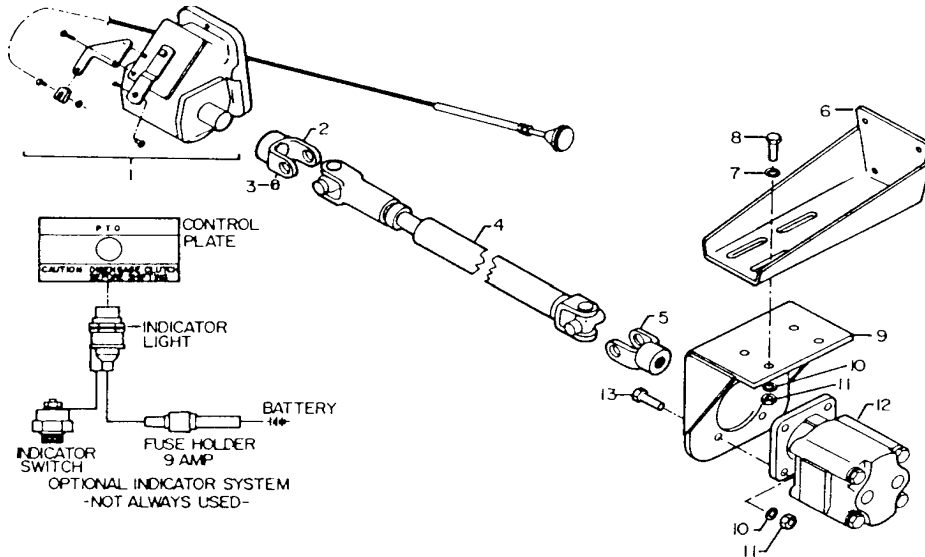

⚠ DANGER

CONTACT WITH A ROTATING DRIVELINE
WILL CAUSE
DEATH OR SERIOUS INJURY
KEEP AWAY

- Keep clear of rotating drive shaft.
- Never work on or near an installed power take-off or driveline with the engine running.

70392891

REPAIR KITS

GASKET KIT - 51039013

7Q072212	O-RING - CYL HEAD	2
76039092	GASKET-REAR BRG HSG .006	2
76039093	GASKET-PUMP COVER	1
76039094	GASKET-REAR BRG HSG .010	2
76039111	GASKET-CYL BLOCK BOTTOM	2
76039112	GASKET-FRT BRG HSG	2
76039113	GASKET-VALVE COVER	2
76039114	GASKET-CYL BLOCK TOP	2
76039119	SEAL	1
76039143	GASKET-REAR BRG HSG .015	2
76039144	GASKET-REAR BRG HSG .020	2

CHECK VALVE KIT - 51704358

7Q073017	O-RING	1
70029377	CHECK VALVE INSERT	1
70029468	SHIM .53 ID X .94 OD X .005 THK	1
72066426	BALL .594 DIA	1
76393085	O-RING	1

CLUTCH REPLACEMENT KIT - 51712861

60110273	CLUTCH	1
70732444	CLUTCH HARDWARE	1
72044419	CLUTCH ELECTRICAL FIELD	1
72063050	WASHER 5/16 LOCK	1

CRANKSHAFT KIT - 51070708

51705655	CRANKSHAFT ASM (INCL: KEY & CRANK)	1
70055010	BEARING-REAR CUP	1
70055011	BEARING-FRT CUP	1
70055012	BEARING-FRT CONE	1
70055009	BEARING-REAR CONE	1
72066307	DRIVE PIN	1
60101269	OIL PUMP COLLAR	1

PISTON RING SET - 51014947

70014599	COMPRESSION RING	8
70014600	OIL RING	4

CRANKSHAFT & CRANKSHAFT ASM (51705811)

ITEM	PART NO.	DESCRIPTION	QTY
1.	51704321	CRANKSHAFT	1
2.	60101269	COLLAR-OIL PUMP (PART OF 1)	1REF
3.	60101271	CRANKSHAFT (PART OF 1)	1REF
4.	70055009	BEARING-CONE (PART OF 1)	1REF
5.	70055012	BEARING-CONE (PART OF 1)	1REF
6.	72066307	ROLL PIN (PART OF 1)	1REF
7.	51705709	HOUSING ASM-FRT BRG	1
8.	60025007	HOUSING (PART OF 7)	1REF
9.	70055011	BEARING-CUP (PART OF 7)	1REF
10.	76039119	SEAL (PART OF 7)	1REF
11.	51705710	HOUSING ASM-REAR BRG	1
12.	60025005	HOUSING (PART OF 11)	1REF

13.	70055010	BEARING-CUP (PART OF 11)	1REF
14.	60025012	CRANKCASE	1
15.	72053413	PIPE PLUG	1
16.	60120238	TUBE-OIL SCREEN	1
17.	60120289	SCREEN-OIL	1
18.	72053403	PIPE PLUG 3/8 SH	1
19.	72060025	CAP SCR 5/16-18X1 HHGR5	5
20.	72060731	CAP SCR 5/16-18X3/4 SH	5
21.	72063050	WASHER 5/16 LOCK	5
22.	72066008	CLAMP-OIL SCREEN	1
23.	76039112	GASKET-FRT BRG HSG	2
24.	76039092	GASKET-REAR BRG HSG .006	AR
25.	76039094	GASKET-REAR BRG HSG .010	AR
26.	76039143	GASKET-REAR BRG HSG .015	AR
27.	76039144	GASKET-REAR BRG HSG .020	AR

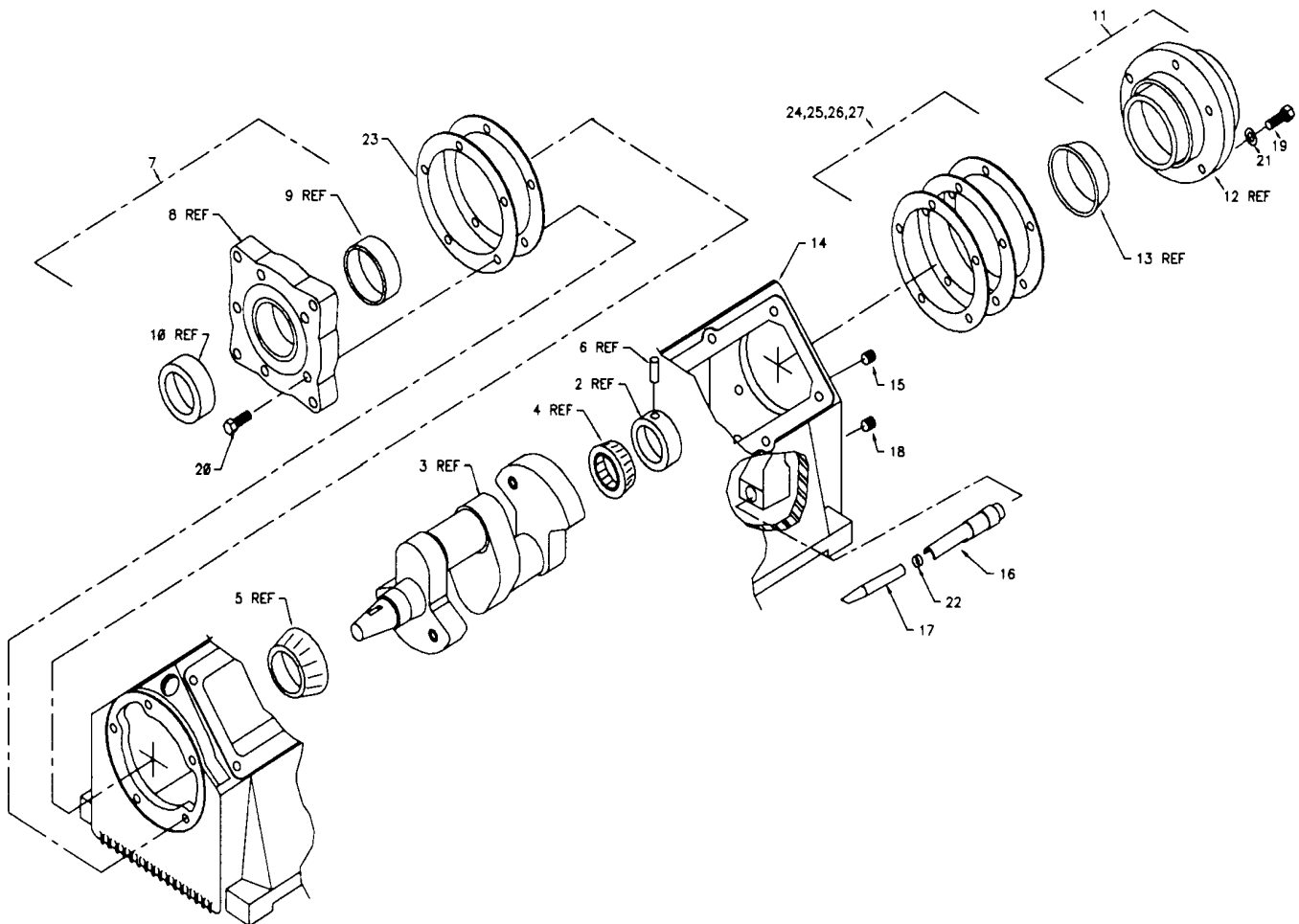

DA425HA10 COMPRESSOR ASM W/O COOLER (51712285-1)

CONTINUED ON FOLLOWING PAGE

ITEM	PART NO.	DESCRIPTION	QTY	ITEM	PART NO.	DESCRIPTION	QTY
1.	52709542	REAR COOLER MTG PLATE	1	49.	72533116	ELBOW 3/4MPT 3/4BARB	2
3.	72053535	STREET ELBOW 3/4NPT 45°	1REF	50.	72533117	BARB NIPPLE	1
4.	72053645	ADAPTER 3/4MP 3/4FPT SWVL	1	51.	73054583	RELIEF VALVE	1
5.	72060046	CAP SCR 3/8-16X1 HHGR5	5	53.	52706924	MOTOR MOUNT	1
6.	72066000	HOSE CLAMP 1/2-1 1/4 #12	4REF	54.	60015015	FAN	1
7.	60110273	CLUTCH-SGL GROOVE	1	55.	60025506	CLUTCH ADAPTER	1
8.	72532832	HOSE FITTING 3/4NPT 3/4HOSE	4REF	56.	60110379	MOTOR ADAPTER	1
9.	77041369	PRESSURE SWITCH	1REF	57.	70143145	SPIDER	1
11.	89392349	HOSE 3/4 300PSI X 7	1REF	58.	72060030	CAP SCR 5/16-18X2-1/4 HHGR5	4
12.	52713405	BASE	1	59.	72053556	ST ELBOW 3/4NPT 90° (part of 62)	1REF
13.	70034293	PLUG 3/4NPT	2	60.	72062038	NUT 7/16-20 HEX (PART OF 64)	1REF
14.	70394268	PLUG 1/2STR	1	61.	72062103	NUT 3/8-16 LOCK	6
15.	72053241	PIPE PLUG 1/4NPT HOLHEX	1	62.	51713112	PRESSURE SWITCH ASM	
16.	72053405	PIPE PLUG 3/4NPT HOLHEX	1		(INCL:3,6,8,9,34,36,38,40,42,44,46,59,66,76-79)	1	
17.	72060025	CAP SCR 5/16-18X1 HHGR5	4	64.	73051505	MOTOR 10GPM	1
18.	72063050	WASHER 5/16 LOCK	8	65.	52713084	FRONT ENCLOSURE PANEL	2
19.	72063002	WASHER 5/16 WRT	4	66.	72532952	BRASS INSERT	2REF
20.	76391173	GROMMET	1	67.	76392227	GROMMET	1
21.	76393038	GROMMET 7/16	1	68.	72661301	POP RIVET .156	2
22.	51707079	COMPRESSOR (SEE DRAWING)	1	69.	70029117	IDENT PLACARD	1
23.	70039124	TAG-SYNTHETIC OIL	1	70.	89086089	SYNTHETIC OIL	2QTS
24.	70143495	BREATHER CAP	1REF	73.	72601652	MACH SCR 1/4-20X3/4 TRHORXSS	18
25.	72053713	ELBOW 3/4MPT 3/4FPT 90°	1	76.	51712189	CHECK VALVE ASM	1REF
26.	72053559	REDUCER BUSHING 1-3/4NPT	1	77.	89392349	HOSE 3/4 300PSI X9	1REF
27.	72053819	PIPE CAP 3/8NPT	1	78.	51711410	WIRE ASM 14GA BLK 6"	1REF
28.	72060048	CAP SCR 3/8-16X1-1/2 HHGR5	10	79.	77044467	3/16 BULLET RECEPT 16-14GA	1REF
29.	72063051	WASHER 3/8 LOCK	7	80.	60119135	TOP ENCLOSURE	1
30.	72531856	REDUCER COUPLING 3/4-1/2NPT	1REF	81.	60119137	PANEL-RH SIDE	1
31.	72532555	HOSE FITTING 3/8 3/8	2	82.	60119138	PANEL-LH SIDE	1
32.	89392426	HOSE 3/8 200PSI X 10	1	83.	76393107	O-RING (PART OF 76)	1REF
33.	52713082	FAN SHROUD	1	84.	60106933	CAP (PART OF 76)	1REF
34.	89044232	WIRE 14GA RED X 3"	1REF	85.	70029468	SHIM (PART OF 76)	1REF
36.	72531130	ELBOW 1/2STR 90°	1REF	86.	70073017	O-RING (PART OF 76)	1REF
38.	89044371	CABLE 14GA 3WIRE	24"	87.	76393085	O-RING (PART OF 76)	1REF
39.	72063003	WASHER 3/8 WRT	12	88.	70029593	INSERT (PART OF 76)	1REF
40.	72053720	ADAPTER 1/4MPT 1/8MPT	1REF	89.	72066426	BALL (PART OF 76)	1REF
41.	70143157	TUBE ASM	1	90.	72053404	PLUG (PART OF 76)	1REF
42.	77040050	TERMINAL-SPD #10 STUD	6REF	91.	72053405	PLUG (PART OF 76)	1REF
44.	89034176	TUBING 1/4	1REF	93.	52712190	CHECK VALVE (PART OF 76)	1REF
46.	72531042	ELBOW 1/8-1/4NPT 90° BRASS	1REF	95.	72053676	ADAPTER 3/4MPT #12MJIC	1
47.	72532358	ADAPTER 3/4MSTR 3/4MJIC	1	96.	51712396	HOSE ASM 3/4X24 FF	1
48.	72532360	ADAPTER 1-1/16MSTR 3/4MJIC	1	97.	72053767	ELBOW #12MSTR #12MJIC 90°	1

DA425HA10 COMPRESSOR ASM W/O COOLER (51712285-2)

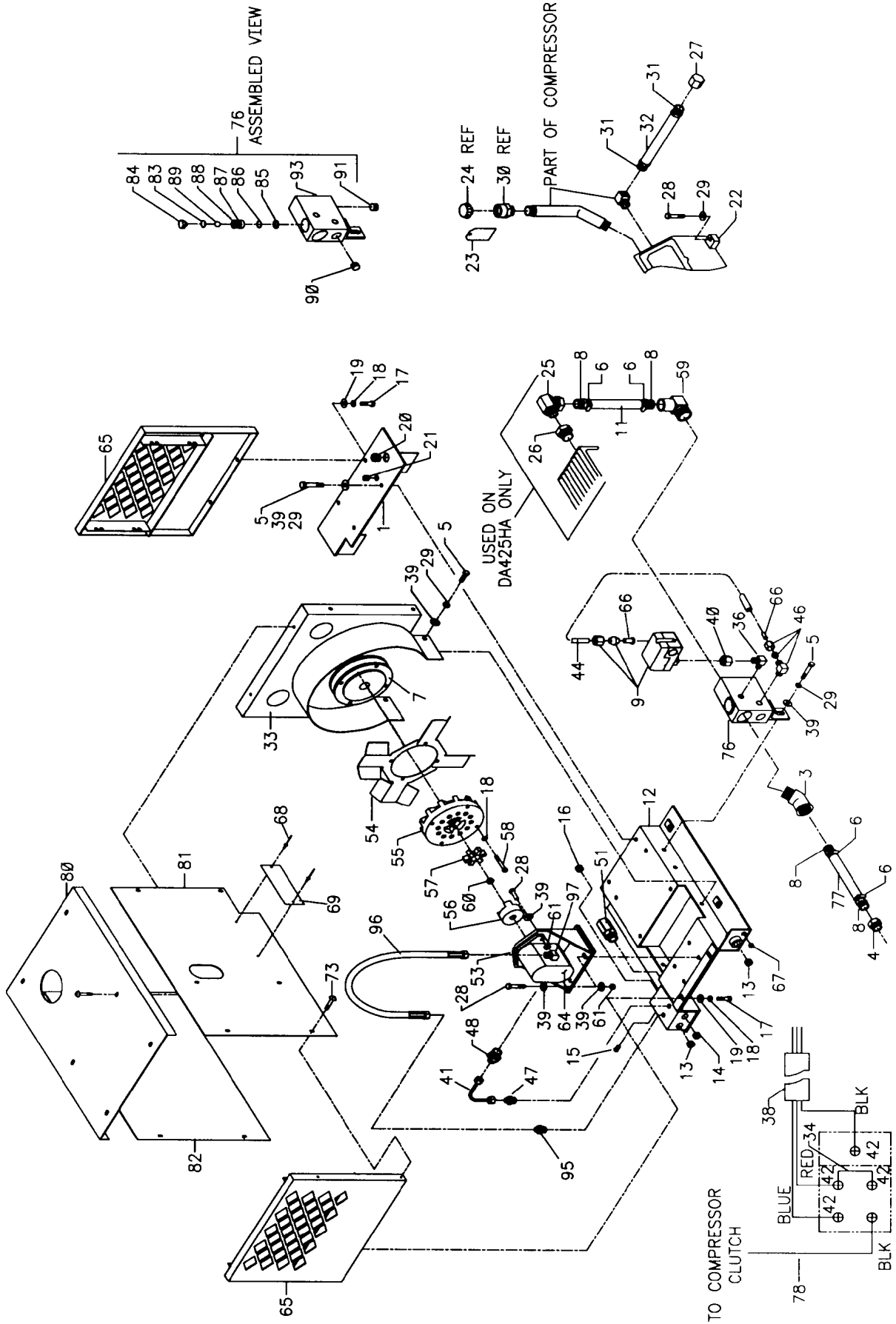

SECTION 5. REPAIR

5-1. GENERAL

This section describes the disassembly and assembly procedures for the air compressor. In all cases, remove the compressor from the vehicle before proceeding with disassembly and repair within a clean environment. Refer to the parts drawing in section 4 of this manual for parts locations.

5-2. PISTON RING REPLACEMENT

1. Remove the pulsation tank.
2. Unscrew the head bolts and remove the heads.

NOTE

A RUBBER FACED Mallet will help when removing the head. Tap the sides of the head carefully until the head is loose. Lift off the heads.

3. Remove the cylinder bolts. Tap the sides of the cylinder several times to break it loose from the gasket. Rock the cylinder back and forth and lift until it is free. Lift it off the pistons.

4. Use a single edged razor blade, or sharp putty knife, to remove the old gasket material.

CAUTION

DO NOT ALLOW THE GASKET MATERIAL TO FALL INTO THE CRANKCASE. DO NOT NICK THE HEAD, CYLINDER, OR CRANKCASE MATING FACES WHILE REMOVING THE OLD GASKET. REMOVE ALL OF THE OLD GASKET MATERIAL TO PROVIDE A SMOOTH, CLEAN SURFACE FOR THE NEW GASKET. FAILURE TO FOLLOW THIS PROCEDURE MAY RESULT IN THE NEED TO RESEAL THE UNIT LATER.

5. Hone the cylinder to break the glaze and to remove the buildup at the top of the cylinders.
6. Measure the inside diameter of the cylinder for roundness and excessive wear. The bore should be 2.625" (0.0025" tolerance). If the bore is oversized, the cylinder must be replaced.

7. With a ring expander, remove the compression and oil rings.

8. With the ring expander, install the new ring kit. Make certain that the oil ring is on the bottom and the beveled inside edge of the compression ring is toward the top of the piston.

9. Position the cylinder base gasket on the crankcase. Use a few drops of oil to hold it in position. Install the cylinder block spacer and gasket on the crankcase.

10. Rotate the rings so that the gaps of the three rings are 120° apart. Lightly lubricate the inside of the cylinder. Rotate the crankshaft so that a piston is at the top of the stroke. Compress the rings with a ring compressor, and slide the cylinder over the piston. Repeat for the other piston.

CAUTION

DO NOT LUBRICATE THE RINGS. USE A LIGHT LUBRICANT, SUCH AS WD-40 ONLY, ON THE CYLINDER WALLS. OILING THE RINGS WILL PREVENT THEM FROM SEATING AND CAUSE EXCESSIVE OIL CONSUMPTION.

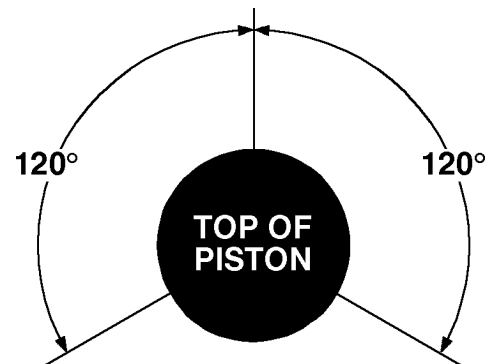

FIGURE E-1. PISTON RING ORIENTATION



FIGURE E-2. CYLINDER HEAD TORQUE SEQUENCE

11. Slide the cylinder down until it mates with the crankcase. Start all cylinder mounting bolts, until they are snug. Torque the bolts to 180 in-lbs in the sequence shown. Do not torque to the full 180 in-lbs all at once, but in 25-50 in-lb increments.

12. Position the gaskets and valve plate on top of the cylinder. Position the head on the cylinder and turn studs finger tight. Torque the studs/nuts to 240 in-lbs in 25-50 pound increments per Figure E-2.

NOTE

INSTALL THE VALVE PLATE WITH THE MARKED SURFACE FACING UP.

13. Install the pulsation tank, and torque to 180 in-lbs.

14. Install the compressor, connect the wiring and the air lines. Test the unit.

NOTE

IF PRESSURE FAILS TO BUILD AND THE COMPRESSOR IS EXCESSIVELY NOISY, CHECK THE VALVE PLATE. IT MAY HAVE BEEN INSTALLED UPSIDE DOWN.

5-3. OIL PUMP REPLACEMENT

1. Remove the bolts and lift off the pump cover.
2. With a single edged razor blade, or sharp putty knife, remove the old gasket material. Take care not to damage the machined surfaces.
3. Lift the pump out of the cavity.
4. Position a new gasket on the rear bearing housing.
5. Insert the pump into the cavity. Position the pump slightly to one side, using a common screwdriver. Wedge the pump into position so that it partially compresses the spring. Note that the driver pin and slot in pump must be in line.
6. Place the pump cover into position and start two bolts (bolts must be diagonally opposed). Strike the pump cover with a rubber faced mallet to jar the pump loose. When the tension spring can be felt against the pump cover, the pump is loose.

7. Insert the two remaining bolts and torque to 180 in-lbs. The bolts should be torqued in a diagonal pattern.

8. Install the air compressor in the vehicle. Connect the air lines and wiring.

5-4. CRANKSHAFT AND BEARING REPLACEMENT

If it is necessary to replace the crankshaft, related components must also be replaced. Replace both bearings, both races, the key, pump collar and pump drive pin.

NOTE

DEPENDING ON THE CONDITION OF THE CRANKSHAFT, BEARING MAY BE REPLACED WITHOUT REPLACING THE CRANKSHAFT. REPLACE THE BEARING RACES WHENEVER THE BEARINGS ARE REPLACED.

1. Remove the pulsation tank, both heads, cylinders, and pistons.
2. Remove the bolts on the connecting rods, and lift them out. Reassemble the connecting rods to be certain that the matched parts remain together on the same crankshaft journals.
3. Remove the pump cover, oil pump, sleeve, spring, and rear bearing housing.
4. Remove the hydraulic motor hub (#301266), and the front bearing housing.
5. Pull the crankshaft from the crankcase.
6. Remove all gasket material with a single edged razor blade, or sharp putty knife.

CAUTION

DO NOT GOUGE THE MACHINED SURFACES WHEN REMOVING THE GASKETS. THIS MAY CAUSE LEAKS.

7. Press the bearing races out of the bearing housing.
8. Press the tapered roller bearings off of the crankshaft if only the bearings are being replaced. If the crankshaft is to be replaced, discard the entire assembly.
9. Press the new bearings into position.

NOTE

THE CRANKSHAFT SHOULD HAVE NEW BEARINGS INSTALLED. IF NOT, PRESS THE NEW BEARINGS INTO POSITION ON THE CRANKSHAFT.

10. Generously oil the front bearing race and install the front bearing housing with gasket. Torque the bolts to 180 in-lbs. Torque the bolts as shown in the pattern below.

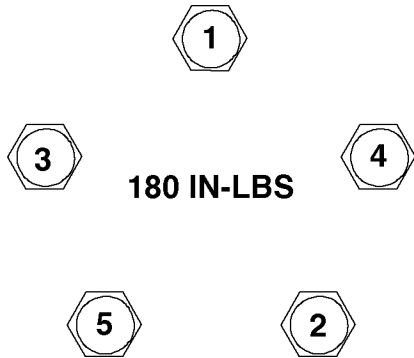

FIGURE E-3. BEARING HOUSING TORQUE SEQUENCE

11. Slide the crankshaft into the crankcase. Generously lubricate the bearing race and install the rear bearing housing and gaskets.

NOTE

GASKET KITS ARE SUPPLIED WITH TWO (2) EACH OF .006, .010, .015, AND .020 GASKETS. USE THESE REAR BEARING GASKETS IN ANY COMBINATION AND QUANTITY TO LIMIT ALL PLAY FRONT TO REAR, BUT STILL ALLOW THE CRANKSHAFT TO TURN FREELY.

12. Install the oil pump (See paragraph 5-3).

13. Install the connecting rods. Thoroughly oil the crankshaft and rods before installing them. When installing the rods, make certain that the tabs are aligned on the same side of the rod as shown below.

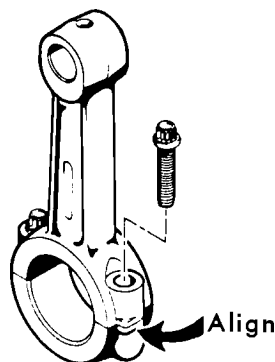

FIGURE E-4. ROD ALIGNMENT

14. Install the pistons, rings, heads and pulsation tank.

5-5. CLUTCH REPLACEMENT

CAUTION

CLUTCH FAILURE MAY BE DUE TO A LEAKING CHECK VALVE. MAKE CERTAIN THAT THE CHECK VALVES ARE FUNCTIONING PROPERLY BEFORE INSTALLING THE NEW CLUTCH. THE CHECK VALVES MAY BE CHECKED BY PRESSURIZING THE TANK AND SHUTTING OFF THE COMPRESSOR. THERE SHOULD BE NO AIR ESCAPING FROM THE UNLOADER VALVE. IF THERE IS AIR ESCAPING, THE CHECK VALVES ARE FAULTY.

The clutch assembly can be removed while the compressor is still on the vehicle. The following procedure should be used.

WARNING

ATTEMPTING TO START THE ENGINE WHILE THE CLUTCH IS BEING REMOVED WILL CAUSE SERIOUS INJURY.

1. Turn on the ignition switch, and move the compressor switch to the on position. This will engage the clutch, and make for easier removal.
2. Remove the bolt in the center of the pulley and insert a 5/8-11 bolt.
3. Tighten the 5/8-11 bolt until the pulley is forced off the crankshaft.
4. Loosen the drive belt and remove the pulley.

NOTE

IF THE DRIVE BELT IS LOOSE BEFORE THE PULLEY IS LOOSE, IT WILL BE DIFFICULT TO HOLD THE PULLEY STATIONARY WHILE TIGHTENING THE 5/8-11 BOLT.

CAUTION

DO NOT USE A WHEEL PULLER ON THE OUTER RIM OF THE PULLEY. THIS CAN RESULT IN DAMAGE TO THE CLUTCH BEARING.

5. Remove the four (4) bolts holding the coil assembly to the front of the compressor.

To reinstall the clutch:

1. Position the magnetic coil assembly over the front bearing housing and secure the assembly with the 1/4-20 bolts. Torque to 85 - 120 in-lbs.
2. Insert the woodruff key into the crankshaft slot.
3. Slide the pulley, spacer, and lock washer onto the end of crankshaft. Be certain that the pulley slot aligns with the woodruff key. Secure them with the 5/16-18 bolts.
4. Rotate the pulley assembly manually to check for interference between the pulley and the coil. If there is interference, disassemble the clutch and repeat the procedure.
5. Install and tighten the drive belts.

6. Connect the coil wire to the air pressure switch.
7. Move the compressor switch in the cab to the on position to activate the clutch. Tighten the center bolt in the pulley.
8. Test the unit for proper operation.

5-6. TROUBLESHOOTING

LOW OIL PRESSURE	LOW OIL LEVEL
	LOOSE PIPE PLUG ON OIL PUMP COVER
	WORN OR DEFECTIVE OIL PUMP
	CRACK OR SCRATCH ON OIL PUMP COVER
NO OIL PRESSURE	DEFECTIVE OIL PUMP
	BLOCKED OIL PASSAGE
	DAMAGED OIL PUMP DRIVE PIN
COMPRESSOR WILL NOT ENGAGE	NO POWER SUPPLIED TO COMPRESSOR
	INTERNAL CIRCUIT BREAKER TRIPPED
	PTO SWITCH NOT ENGAGED
	DEFECTIVE PRESSURE SWITCH OR UNDERHOOD SWITCH
COMPRESSOR ENGAGES BUT WILL NOT PRESSURIZE TANK	COMPRESSOR RELIEF VALVE ENGAGED
	AIR LEAK IN PLUMBING
	WORN PISTON RINGS OR VALVE PLATES
COMPRESSOR DOES NOT RECOVER PRESSURE AS FAST AS IT SHOULD	DEFECTIVE CHECK VALVE / VALVES
	DIRTY FILTER
	AIR LEAK IN PLUMBING
	WORN VALVE PLATES OR PISTON RINGS

FIGURE E-5. TROUBLESHOOTING CHART

SECTION 6. RELAY BOARD OPERATION

6-1. INTRODUCTION

To understand how the relay board operates, it is necessary to understand how the individual relays function.

The Bosch relay (part number 77041251) is a normally open relay between terminals 30 and 87 and normally closed between terminals 30 and 87a. Terminals 85 and 86 energize the relay through the coil. See Figure F-1 and F-2.

Figure F-3 shows the relay board with eight relays identified with the letters “A” through “G” and by their basic function. Example: Relay “A” is the “Power ON/OFF” relay, “C” is the “Compressor Speed Control”, etc. The small numbers shown on the individual terminals of the relay indicate where that terminal is connected through the circuit board, to the terminal bar. Example: Relay “A” top terminal (#9) is connected to terminal 9 of the terminal bar. The terminal bar is provided with 16 individual terminals of which the last two (15 and 16) are not used. Wires connected to the terminal bar have been identified according to their function in the circuit. The number of terminals used vary with each application. Solid lines between relay terminals indicate existing wiring connections, through the circuit board.

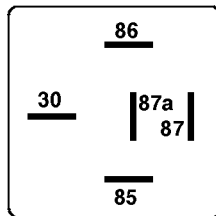

FIGURE F-1. BOTTOM VIEW OF RELAY

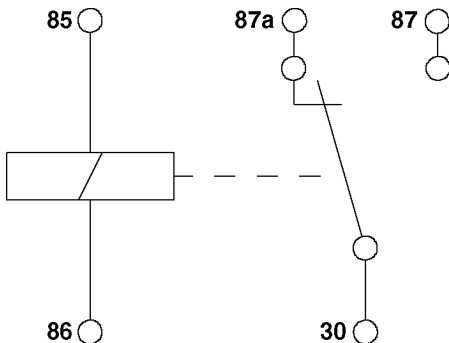

FIGURE F-2. INTERNAL WIRING

The relay board is primarily used on vehicles with remote controlled cranes and remote control cranes and compressors. The circuitry prevents remote starting of the truck engine unless the brakes are applied and the PTO is engaged. It also isolates the crane speed control from the compressor speed control.

6-2. OPERATION

6-2-1. IGNITION “ON”

When the ignition switch of the vehicle is turned “ON”, terminal 9 of the terminal bar is “HOT”. The coil of relay “A” is energized and voltage from terminal 1 of the terminal bar becomes present at terminals “A” of relays “A”, “B”, “E” and “H”. See Figure F-4.

6-2-2. REMOTE STARTING THE VEHICLE

The vehicle can be remotely started from the remote control handle after the power is turned “ON” at the handle.

To start the vehicle, the engine start switch at the handle must be depressed. When this is accomplished, terminal 11 of the terminal block becomes “HOT”. See Figure F-6.

The truck starter is energized when terminals 11 and 12 of the terminal bar are connected through the relay board. When terminal 11 is “HOT”, the coil in relay “F” is energized connecting relay terminal 12 and “B” on relays “F” and “G”. If terminal 14 of relay “H” and terminal 13 of relay “G” are grounded (brakes and PTO engaged) terminals “B” of relays “F” and “G” are “HOT”. Since terminal “B” of relay “F” is “HOT”, the truck starter solenoid is activated. Energized circuits are shown as bold in Figure F-6.

6-2-3. REMOTE ENGINE STOP

When the engine stop button is depressed on the remote control handle, voltage is applied to terminal 6 of the terminal block and of relay “D”. The coil in relay “D” is energized and the ground of the fuel solenoid/distributor coil is interrupted because current can no longer flow from terminal 7 to 8. Relay “D” is normally closed between terminals 7 and 8. See Figure F-3.

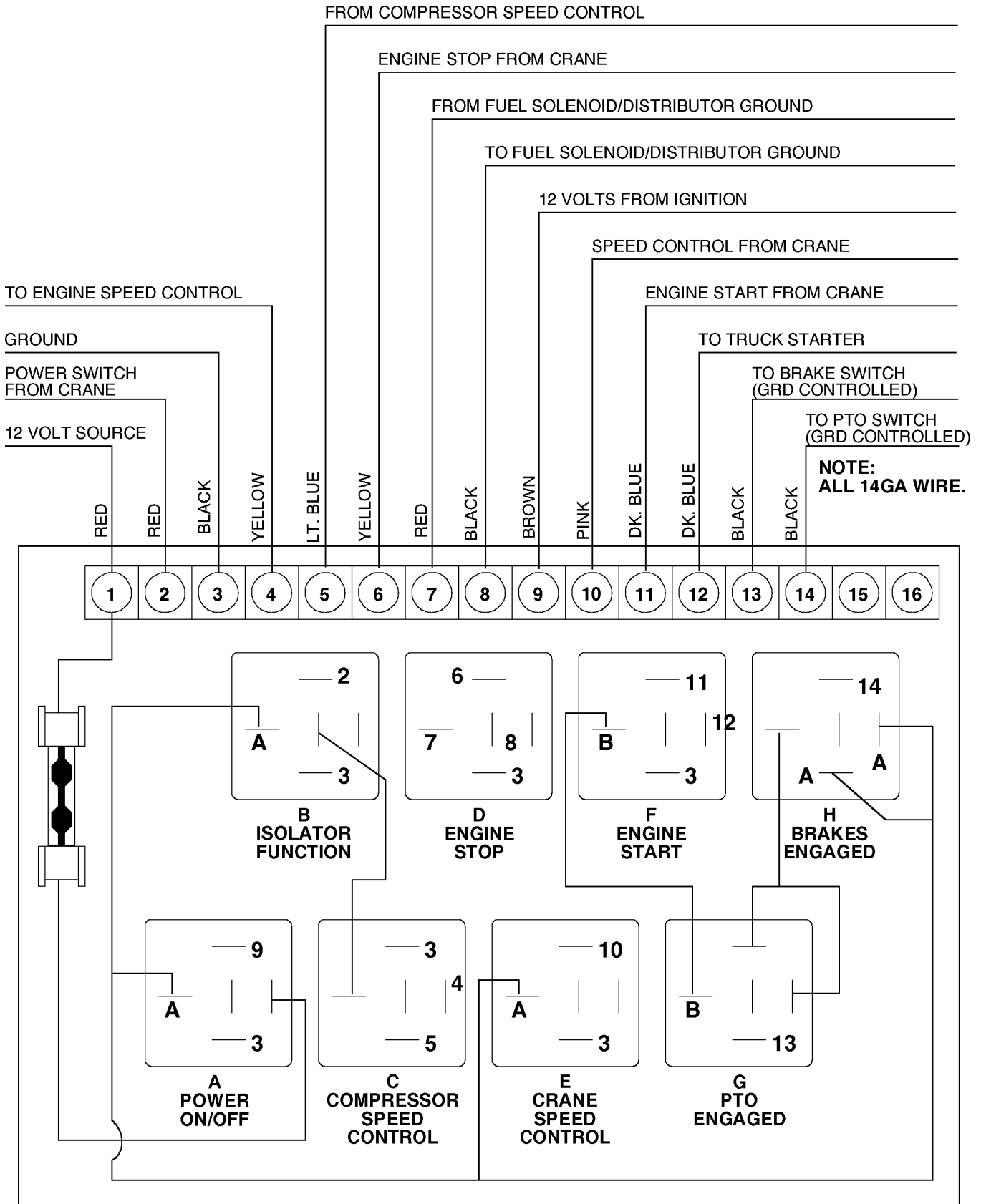

FIGURE F-3. RELAY BOARD - COMPONENTS & WIRING

6-2-4. REMOTE ENGINE SPEED (FROM CRANE)

Engine speed can be controlled from the remote control handle. When the engine speed switch is activated, voltage is applied at terminal 10 of relay "E". The coil of relay "E" is energized and current is allowed to flow to the speed control coil. The speed of the engine will remain higher as long as the engine speed switch in the remote control handle is allowed to remain in the same position. If this switch is returned to its original position, the engine speed control coil will be de-energized through relay "E".

6-2-5. COMPRESSOR ENGINE SPEED CONTROL (COMPRESSOR ONLY)

When the compressor "kicks in" or goes into the charging mode, the engine speed of the vehicle is increased; when it "kicks out" or goes in the unloading mode, the engine speed is reduced.

When the compressor goes into the charging mode, terminal 5 of relay "C" energizes the coil in the relay, connecting terminal 4 to terminal "C" of the relay which is "HOT" from relay "B". Reference Figure F-7 showing circuits energized (in bold) when engine speed is increased by the compressor.

6-2-6. ENGINE SPEED CONTROL WHEN BOTH CRANE AND COMPRESSOR ARE USED SIMULTANEOUSLY

When the engine speed has been increased from the remote control handle to operate the crane, it (the speed) will remain unchanged regardless of the speed signals received from the compressor.

If, however, the crane is operated at slow engine speed simultaneously with the compressor, the speed increase signals from the compressor will increase engine speed. To prevent the compressor from unexpectedly increasing the engine speed when handling a load with the crane, an isolator (relay "B") has been placed in the circuit. This relay "B" is energized separately from the crane compartment.

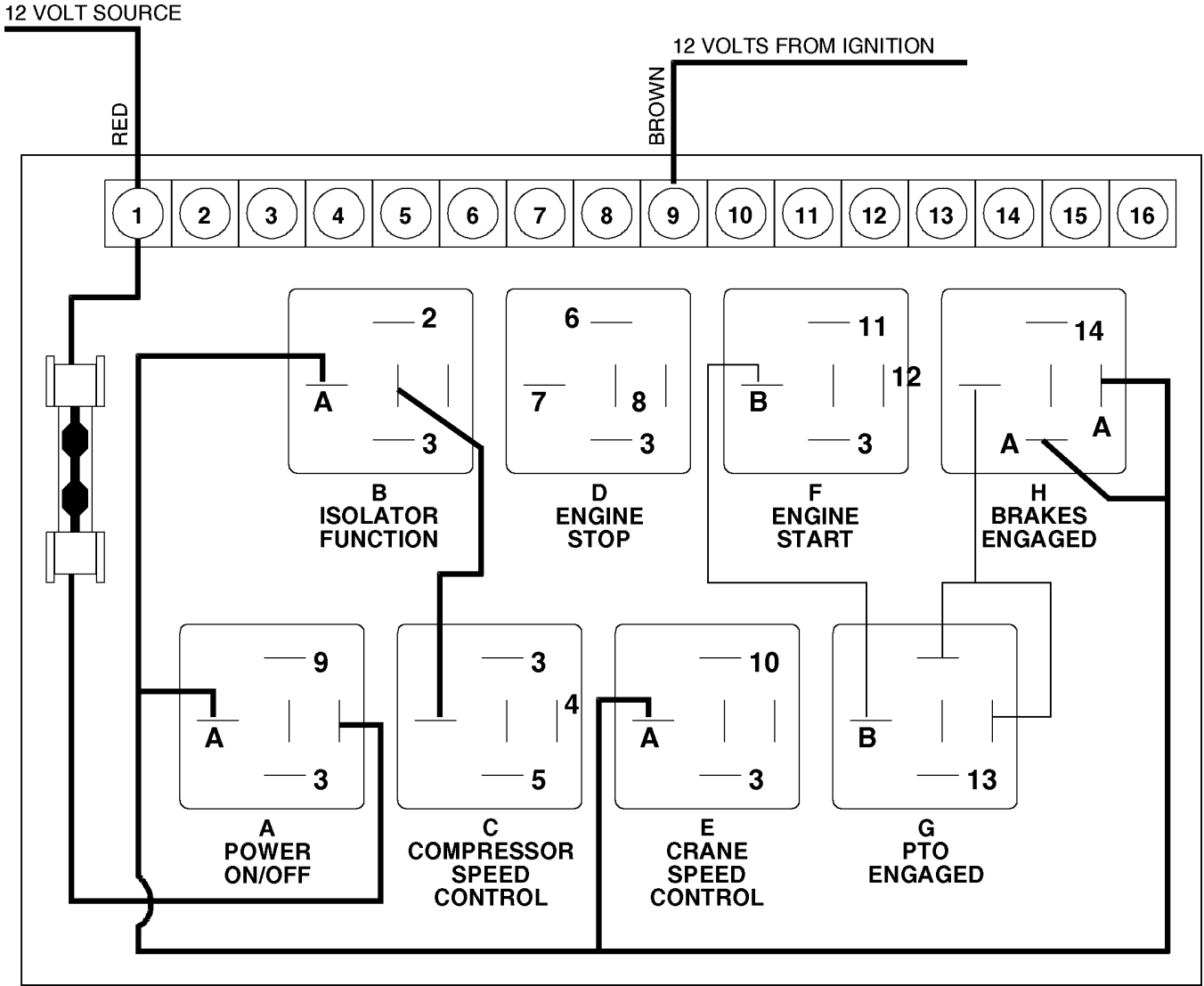

FIGURE F-4. IGNITION "ON"

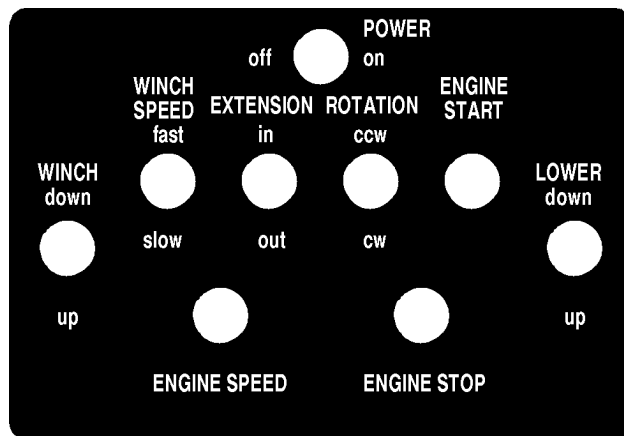

FIGURE F-5. REMOTE CONTROL HANDLE - TYPICAL

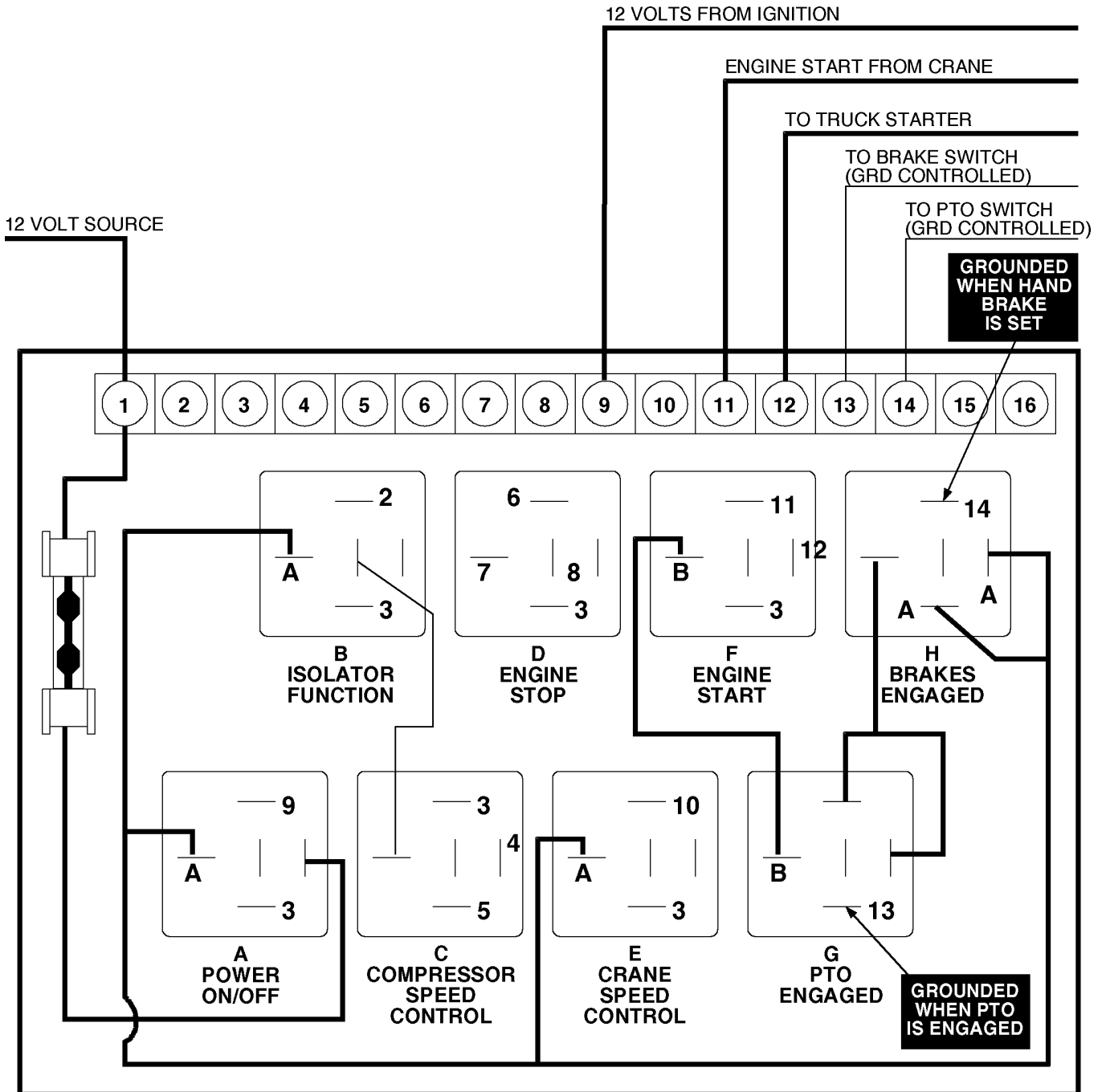

FIGURE F-6. REMOTE STARTING OF VEHICLE - IGNITION "ON"

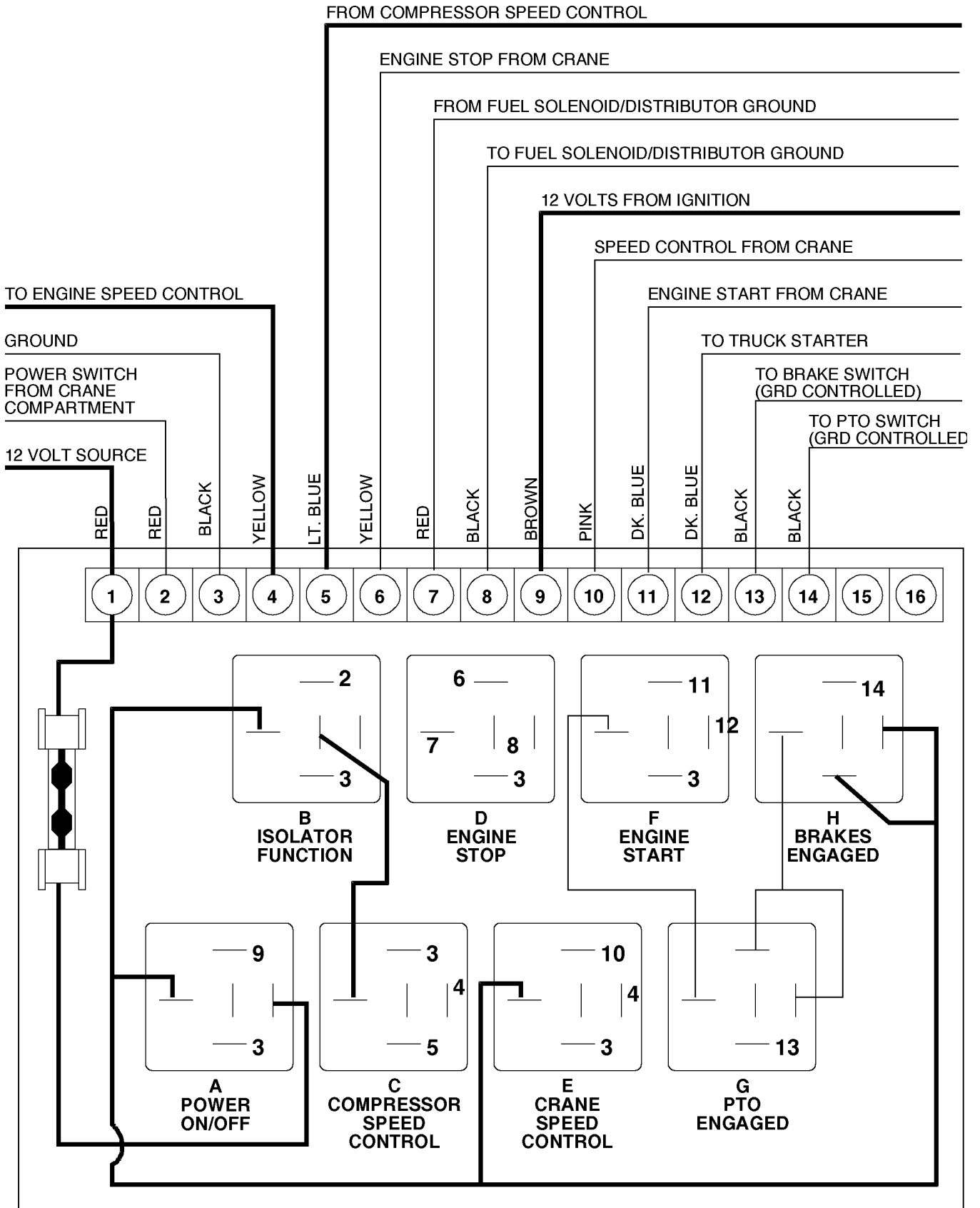

FIGURE F-7. SPEED CONTROL - COMPRESSOR ONLY

6-3. INSTALLATION

1. Locate an area in the engine compartment that will both provide some protection against damage and accessibility for wiring.
2. Provide adequate space between the mounting surface and the back of the circuit board in order to prevent electrical contact. Failure to do so will cause erratic operation and/or circuit board failure.
3. Connect control wiring as indicated in Wiring Chart.
4. Jumper wires connections:

4-1. Jumper wires must connect J to K, and L to M for 12 volts excited systems. Remove the connecting wires between I to J and M to N.

4-2. Jumper wires must connect I to J, and M to N for ground excited systems*. Remove the connecting wires between J to K and L to M.

WIRING CHART

TERM	WIRING CONNECTION
1	12-VOLT
2	POWER SWITCH FROM CRANE
3	GROUND
4	TO SPEED CONTROL
5	SPEED CONTROL FROM COMPRESSOR
6	ENGINE STOP FROM CRANE
7	FROM FUEL SOLENOID / DISTRIBUTOR GRD
8	TO FUEL SOLENOID / DISTRIBUTOR GRD
9	12-VOLT FROM IGNITION
10	SPEED CONTROL FROM CRANE
11	ENGINE START FROM CRANE
12	TO TRUCK STARTER
13	TO BRAKE SWITCH, CONTROLLED
14	TO PTO SWITCH, CONTROLLED
15	NC
16	NC

RELAY	FUNCTION
A	ON / OFF, POWER
B	ISOLATION, SPEED CONTROL
C	COMPRESSOR, SPEED CONTROL
D	ENGINE STOP
E	CRANE SPEED CONTROL
F	ENGINE START
G	BRAKE SWITCH, CONTROLLED
H	PTO SWITCH

WARNING

Failure to remove the extra connecting wire will cause the relay board to fail. Check jumper wire connections of relay board being replaced. (Most relay boards are wired as stated in item 4-1.)

* NOTES

- Circuits that could be ground excited are 6 - 10 & 11.
- Quick Check: (Before connecting wires to circuit board) Activate the engine stop switch from the crane. If terminal 6 is hot, wire per 4-1. If not, wire per 4-2.

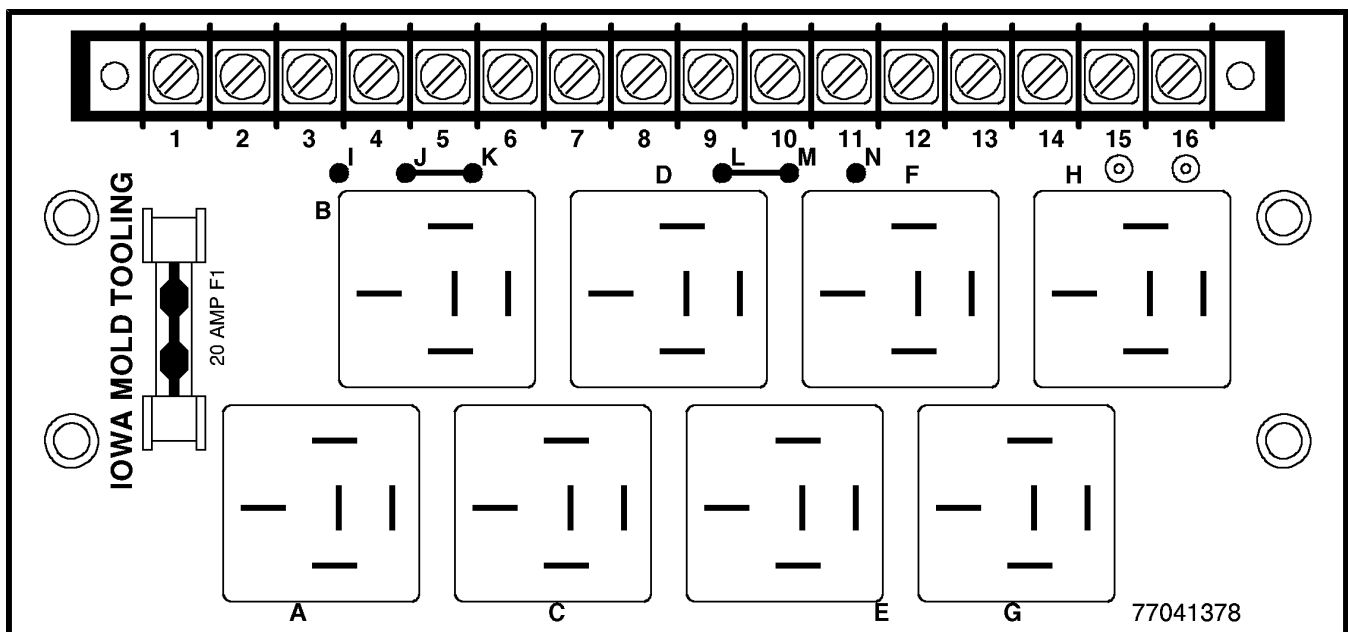

FIGURE F-8. RELAY BOARD (77041378) WIRING INSTRUCTIONS

The information within this manual has been compiled and checked but errors do occur. To provide our customers with a method of communicating those errors we have provided the Manual Change Request form below. In addition to error reporting, you are encouraged to suggest changes or additions to the manual which would be of benefit to you. We cannot guarantee that these additions will be made but we do promise to consider them. When completing the form, please write or print clearly. Submit a copy of the completed form to the address listed below.

MANUAL CHANGE REQUEST

DATE	PRODUCT MANUAL	MANUAL PART NO.
SUBMITTED BY		
COMPANY		
ADDRESS		
CITY, STATE, ZIP		
TELEPHONE		

ERROR FOUND

LOCATION OF ERROR (page no.): _____

DESCRIPTION OF ERROR: _____

REQUEST FOR ADDITION TO MANUAL

DESCRIPTION OF ADDITION: _____

REASON FOR ADDITION: _____

MAIL TO: IOWA MOLD TOOLING Co., Inc.
Box 189,
Garner IA 50438-0189
ATTN: Technical Publications

LIMITED WARRANTY

WARRANTY COVERAGE - Products manufactured by Iowa Mold Tooling Co., Inc. (IMT) are warranted to be free from defects in material and workmanship, under proper use, application and maintenance in accordance with IMT's written recommendations, instructions and specifications as follows:

1. Ninety (90) days; labor on IMT workmanship from the date of shipment to the end user.
2. One (1) year; original IMT parts from the date of shipment to the end user.

IMT's obligation under this warranty is limited to, and the sole remedy for any such defect shall be the repair or replacement (at IMT's option) of unaltered parts returned to IMT, freight prepaid, and proven to have such defect, provided such defect occurs within the above stated warranty period and is reported within fourteen (14) days of its occurrence.

IMPLIED WARRANTY EXCLUDED - This is the only authorized IMT warranty and is in lieu of all other express or implied warranties or representations, including any implied warranties of merchantability or fitness for any particular purpose or of any other obligations on the part of IMT.

ITEMS EXCLUDED - The manufacturer gives no warranty on any components purchased by the manufacturer, and such components as are covered only by the warranties of their respective manufacturers.

WARRANTY CLAIMS - Warranty claims must be submitted and shall be processed in accordance with IMT's established warranty claim procedure.

WARRANTY SERVICE - Warranty service will be performed by any IMT distributor authorized to sell new IMT products of the type involved or by any IMT Service Center authorized to service the type of product involved or by IMT in the event of direct sales made by IMT. At the time of requesting warranty service, the purchaser must present evidence of the date of delivery of the product. The purchaser shall pay any premium for overtime labor requested by the purchaser, any charge for making service calls and for transporting the equipment to the place where warranty work is performed.

WARRANTY VOIDED - All obligations of IMT under this warranty shall be terminated: (1) if service other than normal maintenance or normal replacement of service items is performed by someone other than an authorized IMT dealer, (2) if product is modified or altered in ways not approved by IMT.

PURCHASER'S RESPONSIBILITY - This warranty covers only defective material and workmanship. It does not cover depreciation or damage caused by normal wear, accident, improper protection in storage, or improper use. The purchaser has the obligation of performing the care and maintenance duties discussed in IMT's written recommendations, instructions and specifications. Any damage which results because of purchaser's failure to perform such duties shall not be covered by this warranty. The cost of normal maintenance and normal replacement of service items such as filters, belts, etc. shall be paid by the purchaser.

CONSEQUENTIAL DAMAGES - The only remedies the purchaser has in connection with the breach or performance of any warranty on IMT products are those set forth above. In no event will the dealer, IMT or any company affiliated with IMT, be liable for business interruptions, loss of sales and/or profits, rental or substitute equipment, costs of delay or for any other special, indirect, incidental or consequential losses, costs or damages.

REPRESENTATIONS EXCLUDED - IMT products are subject to no expressed, implied or statutory warranty other than herein set forth, and no agent, representative or distributor of the manufacturer has any authority to alter the terms of this warranty in any way whatsoever or to make any representations or promises, express or implied, as to the quality or performance of IMT products other than those set forth above.

CHANGE IN DESIGN - IMT reserves the right to make changes in design or improvements upon its products without imposing any obligation upon itself to install the same upon its products theretofore manufactured.

Effective January, 1985

This parts manual is provided to the user to assist in servicing the equipment. It is the property of Iowa Mold Tooling Co., Inc and, as such, may not be reproduced either whole or in part, whether by chemical, electrostatic, mechanical or photographic means without the expressed written permission of an officer of Iowa Mold Tooling Co., Inc. One manual is provided with each piece of new equipment and additional manuals may be obtained at a nominal price.



IOWA MOLD TOOLING CO., INC.
BOX 189, GARNER, IA 50438-0189
TEL: 515-923-3711
TECHNICAL SUPPORT FAX: 515-923-2424