

DA425EA: 99900679: 19990121



**Model DA425EA**  
**Underhood Air Compressor**  
(Replaces Model HD750)



**IOWA MOLD TOOLING CO., INC.**  
BOX 189, 500 HWY 18 WEST, GARNER, IA 50438  
TEL: 515-923-3711  
TECHNICAL SUPPORT FAX: 515-923-2424  
MANUAL PART NUMBER 99900679

# PRECAUTIONS

## Read before operating your compressor!



71393886



DANGER

**EXPLODING TANK WILL CAUSE DEATH, SERIOUS INJURY OR PROPERTY DAMAGE**

- Drain air tank after each use to prevent moisture build-up and corrosion which leads to tank failure.
- Assure that tank and compressor relief valves work properly, and are at correct pressure settings.
- **DO NOT** modify or repair air tank.
- **NEVER** drive vehicle with pressure in air tank.

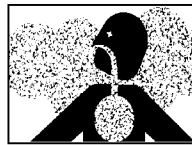

Failure to follow operating and maintenance procedures as outlined in this manual could result in equipment damage, personal injury or death. Follow all maintenance procedures and intervals.



Do not use air from this compressor for breathing or food processing. Air from this compressor will cause severe injury or death if used for breathing or food processing.



Maintenance must be performed only by trained and qualified personnel, using correct tools, specified torques and approved replacement parts.

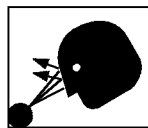

Hot oil under pressure can cause severe injury or death. Shut down, let cool and relieve pressure in compressor before servicing.



All electrical components and cable wiring must be installed and grounded in accordance with NFPA, national electrical codes and applicable state and local codes.



Do not overfill the compressor with oil. Use correct quantity of manufacturer's lubricant. Repair leaks and clean spills immediately.



Before removing guards or servicing the compressor, disconnect all power supplies. Display warning signs and lock out electrical circuits.



Compressors generate high temperatures. Do not touch or otherwise come in contact with hot surfaces. Doing so can cause severe personal injury.



All guards must be in position and secure before and during operation.

# TABLE OF CONTENTS

PARA	TITLE	PAGE
<b>SPARE PARTS LIST</b>		
<b>Section 1. SPECIFICATIONS</b>		
1-1.	GENERAL .....	1-1
1-2.	SPECIFICATIONS .....	1-1
<b>Section 2. INSTALLATION</b>		
2-1.	GENERAL .....	2-1
2-2.	AIR COMPRESSOR .....	2-1
2-3.	UNDERDASH SWITCH .....	2-1
2-4.	UNDERHOOD SWITCH .....	2-1
<b>Section 3. OPERATION</b>		
3-1.	GENERAL .....	3-1
3-2.	OPERATION .....	3-1
<b>Section 4. MAINTENANCE &amp; PARTS</b>		
4-1.	GENERAL .....	4-1
	PRESSURE SWITCH INSTALLATION INSTRUCTIONS .....	4-5
<b>Section 5. REPAIR</b>		
5-1.	GENERAL .....	5-1
5-2.	PISTON RING REPLACEMENT .....	5-1
5-3.	OIL PUMP REPLACEMENT .....	5-2
5-4.	CRANKSHAFT AND BEARING REPLACEMENT .....	5-2
5-5.	CLUTCH REPLACEMENT .....	5-3
5-6.	TROUBLESHOOTING .....	5-4

# LIST OF ILLUSTRATIONS

FIGURE	TITLE (PART NUMBER)	PAGE
A-1.	OUTSIDE DIMENSIONS .....	1-1
C-1.	AUTOMATIC SPEED CONTROL OPTION .....	3-1
D-1.	ROUTINE MAINTENANCE CHECKLIST .....	4-1
D-2.	AIR COMPRESSOR - PARTS (51711330) .....	4-2
D-2A.	AIR COMPRESSOR - PARTS (51711330) .....	4-3
D-2B.	AIR COMPRESSOR - PARTS (51711330) .....	4-4
D-3.	PRESSURE SWITCH KIT & INSTALLATION INSTR (51710224) .....	4-5
D-4.	OPTION-SOLBERG AIR FILTER KIT (51709435) .....	4-6
D-5.	OPTION-AIR FILTER KIT (95709998) .....	4-6
	REPAIR KITS .....	4-6
E-1.	PISTON RING ORIENTATION .....	5-1
E-2.	CYLINDER HEAD TORQUE SEQUENCE .....	5-1
E-3.	BEARING HOUSING TORQUE SEQUENCE .....	5-3
E-4.	ROD ALIGNMENT .....	5-3
E-5.	TROUBLESHOOTING CHART .....	5-4

# RECOMMENDED SPARE PARTS LIST

**1 Year Supply**

**DA425EA AIR COMPRESSOR**

For Manual: 99900679

This spare parts list does not necessarily indicate that the items can be expected to fail in the course of a year. It is intended to provide the user with a stock of parts sufficient to keep the unit operating with minimal down-time waiting for parts. There may be parts failures not covered by this list. Parts not listed are considered as not being Critical or Normal Wear items during the first year of operations and you need to contact the distributor or manufacturer for availability.

ASSEMBLY DESIGNATION	ITEM NO.	PART NO.	DESCRIPTION	QTY	CODE	SHELF LIFE (MO)	ORDER QTY
51711330.01.19970619	<b>UNDERHOOD AIR COMPRESSOR</b>						
	2	60025010	CYLINDER BLOCK	2	W		
	3	60025008	CYLINDER HEAD	2	W		
	5	70073031	VALVE PLATE	2	C		
	18	76039141	AIR INTAKE FILTER-FOAM	2	P		
	33	76393802	FILTER SCREEN	4	P		
	44	51704023	INSERT ASM	1	C		
	66	51029296	CONNECTING ROD	4	W		
	84	51704321	CRANKSHAFT ASM	1	W		
	87	51014947	RING SET	1	W		
	92	70056437	PULLEY- 1 GROOVE	1	C		
		70056304	PULLEY- 2 GROOVE	1	C		
		70056441	PULLEY- 6 GROOVE	1	C		
		70056442	PULLEY- 7 GROOVE	1	C		
	93	77044419	CLUTCH FIELD	1	C		
	REF	51039013	GASKET SET	1	C		
	REF	77041369	PRESSURE SWITCH	1	C		
	REF	51086090	OIL-2 QTS	2	P		

# SECTION 1. SPECIFICATIONS

## 1-1. GENERAL

The IMT DA425EA air compressor is an underhood, engine mounted, single stage, air cooled, 4-cylinder, pressure lubricated unit, with a delivery rate of 25 CFM at 1400 RPM. The compressor is belt driven from the engine crankshaft, through a magnetic clutch. It is engaged and disengaged by use of an air pressure sensing, electric switch. The pressure switch is preset on factory installed units at approximately 120 PSI to engage, and 150 PSI to disengage.

**CAUTION**

OPERATING THE COMPRESSOR AT PRESSURES ABOVE 150 PSI WILL SHORTEN THE SERVICE LIFE AND VOID THE WARRANTY.

## 1-2. SPECIFICATIONS

Bore	2-5/8"
Stroke	2"
Cylinder Configuration	V4
Displacement	35 CFM*
Delivery	25 CFM*
Lubrication	Oil Pump
Oil Capacity	1-1/3 qts
Cooling	Air
Height	13-3/8"
Width	15-3/4"
Length	13-7/8"
Material	Aluminum Alloy
Weight	75 lbs.
* @ 1400 RPM - 100 PSI	

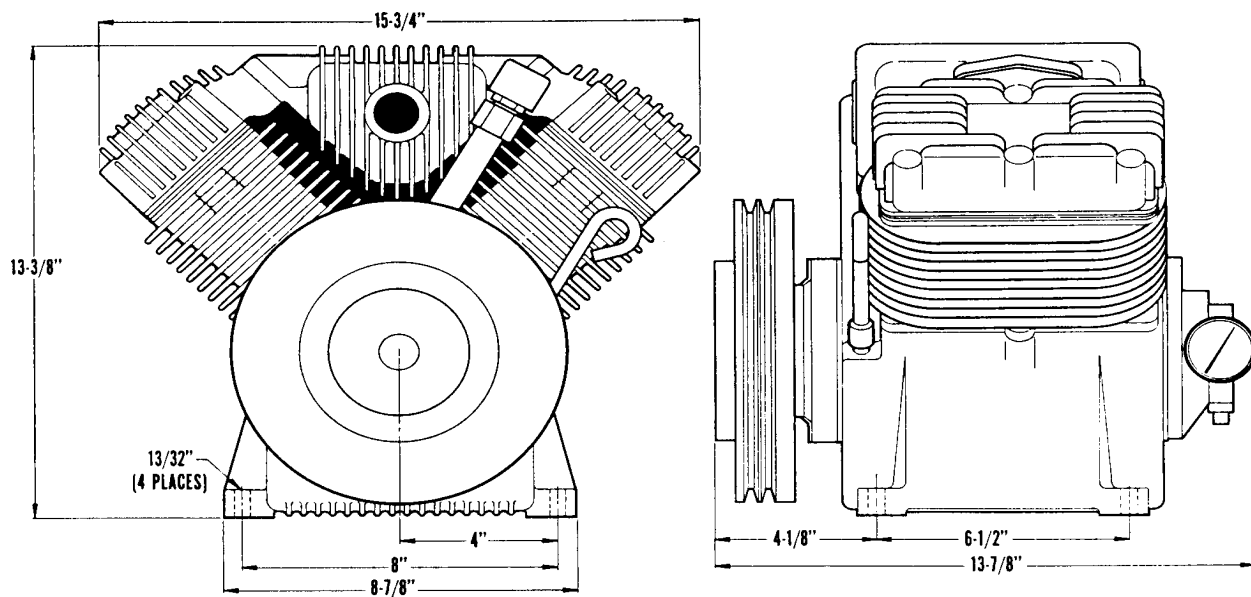

**FIGURE A-1. OUTSIDE DIMENSIONS**

## SECTION 2. INSTALLATION

### 2-1. GENERAL

This section pertains to the installation of the IMT DA425EA compressor and related components. Because installations will vary somewhat, dependent on the chassis, it will describe the installation in general terms only.

### 2-2. AIR COMPRESSOR

Each installation will differ dependent on the chassis make, model, year of manufacture, and optional equipment. Refer to the mounting kit for specific information relating to your application.

### 2-3. UNDERDASH SWITCH

The installation kit will include the correct bracket for the installation of the compressor, power switch and the engine speed control. The bracket may house switches for other functions, depending on the total system.

1. Drill mounting holes in the underside of the dash. It may be possible to utilize existing holes.
2. Install the switch, or switches, needed for your installation.
3. Route the needed wiring harness to the rear of the bracket and connect to the proper switches.
4. Securely fasten the assembled switch bracket to the dash with bolts, nuts, and washers provided.

#### NOTE

IF THE DASHBOARD IS PLASTIC, THE GROUND WIRE MUST BE CONNECTED TO CHASSIS GROUND. THE PLASTIC DASHBOARD IS NOT CONDUCTIVE AND WILL NOT PROVIDE A GROUND.

5. Connect the positive side of the compressor switch to the power switch. Connect the other side of the switch to the underhood safety switch and the indicator lamp.
6. Install the throttle cable mounting bracket to the underside of the dash, near the switch bracket. Install the cable and connect to the carburetor linkage. Make certain that there is enough free play to allow the engine to return to normal idle.

### 2-4. UNDERHOOD SWITCH

The purpose of the underhood switch is to prevent the compressor from running unless the vehicle's hood is raised. This will ensure sufficient air flow to the compressor during operation.

1. Select a location for the mercury switch that will provide protection for the glass envelope and keep the switch contacts open when the hood is closed. The mercury should not be in contact with the contacts to accomplish this.
2. Drill a 1/16 inch hole in the desired location and install the switch bracket. Install the switch in the bracket. Connect one lead to the underdash switch, the other to the compressor pressure switch. When wired properly, the switch in the cab must be "ON" and the hood must be raised in order for the compressor to operate.

#### CAUTION

WARRANTY ON THE COMPRESSOR WILL BE VOID IF THE UNDERHOOD SAFETY SWITCH IS NOT USED. FAILURE TO USE THIS SWITCH WILL ALLOW THE COMPRESSOR TO OPERATE WITH THE HOOD CLOSED AND WILL CAUSE OVERHEATING.

## SECTION 3. OPERATION

### 3-1. GENERAL

Each compressor is bench tested under load at the factory to ensure proper break-in and operation. While it is not necessary to follow any break-in procedure, the following checks should be made before putting the unit into service, as well as, periodically during use.

1. Before start-up:

A. Check the oil level in the compressor crankcase with the dipstick on the unit. If oil is needed, use only IMT's synthetic compressor oil.

B. Check the air intake filter pads on each head to make certain that they are clean and unobstructed. Dirty filters are a possible cause of reduced air output.

2. With the compressor engaged:

On units having the automatic speed control option, check the engine RPM for proper setting (1400 RPM max.) under compressor load.

### 3-2. OPERATION

To use the compressor, raise the hood to provide adequate ventilation, start the vehicle engine, and engage the compressor by operating the compressor switch in the cab. On systems without automatic engine speed control, adjust the engine RPM with the manual throttle cable to maintain the proper RPM setting while the compressor is pumping.

The system will now function automatically. It will engage the compressor clutch when the air pressure is below 120 psi, and disengage when the air pressure reaches 150 psi.

#### NOTE

ON UNITS WITH MANUAL ENGINE SPEED CONTROL, THE ENGINE RPM WILL INCREASE WHEN THE COMPRESSOR CLUTCH DISENGAGES.

#### CAUTION

THIS UNIT IS EQUIPPED WITH AN UNDERHOOD SAFETY SWITCH WHICH REQUIRES THAT THE HOOD BE RAISED WHILE THE COMPRESSOR IS IN OPERATION. THIS IS INSTALLED TO ENSURE THAT THE UNIT HAS ADEQUATE VENTILATION, AND THAT THE UNIT IS NOT INADVERTANTLY LEFT ON WHEN NOT IN USE AND THE VEHICLE IS IN MOTION. BYPASSING THIS SAFETY DEVICE, OR OPERATING THIS UNIT IN EXCESS OF 1400 RPM, WILL VOID THE WARRANTY, AND WILL SHORTEN THE NORMAL SERVICE LIFE OF THE COMPRESSOR.





## Section 4. MAINTENANCE & PARTS

### 4-1. GENERAL

The following table is a list of routine maintenance items, including service intervals. It also includes a parts list and assembly drawing of the compressor.

MAINTENANCE OPERATION	SERVICE INTERVALS			
	DAILY	WEEKLY	250/3	500/6
AIR INTAKE - INSPECT AND CLEAN				
CRANKCASE OIL LEVEL - CHECK, ADD IF NEEDED				
CRANKCASE OIL - CHANGE (SEE NOTE 1)				
CHECK CYLINDER HEAD BOLT TORQUE (SEE NOTE 2)				
COOLING VANES (FINS) - CLEAN				
SAFETY VALVES - CHECK OPERATION				
SAFETY VALVES - CLEAN				
BELT TENSION - CHECK				
ELECTRIC CLUTCH - CHECK OPERATION				
AIR RECEIVER - DRAIN CONDENSATION				
RECEIVER SAFETY VALVES - CHECK OPERATION				
TIGHTEN AND CHECK ALL VALVES				
CHECK ALL ELECTRICAL CONNECTIONS				
CHECK FITTINGS AND AIR LINES FOR LEAKS				
INSPECT CHECK VALVES FOR PROPER OPERATION				
INSPECT CHECK VALVES FOR CARBON BUILDUP				

Service intervals are listed as hours/months, whichever occurs first.

Use only IMT's synthetic compressor oil. The use of any other oil causes excessive carbon buildup, and will void the warranty on the compressor.

NOTE 1. Under normal operating conditions, oil changes are required every 3 months. When operating in a dirty environment, change the oil more frequently as your particular operating conditions dictate. Oil capacity is 1-1/3 quarts.

NOTE 2. Cylinder head bolt torque MUST be checked after the initial 8-10 hours of operation. The compressor must be cold (room temperature) before retorquing of bolts. Torque bolts to 180 in-lbs plus or minus 10 in-lbs.

**FIGURE D-1. ROUTINE MAINTENANCE CHECKLIST**

**FIGURE D-2. DA425EA UNDERHOOD AIR COMPRESSOR (51711330-1)**

ITEM	PART NO.	DESCRIPTION	QTY	ITEM	PART NO.	DESCRIPTION	QTY
1.	60025012	CRANKCASE (PART OF 83)	1REF	55.	72066307	DRIVE PIN (PART OF 84)	1REF
2.	60025010	CYLINDER BLOCK	2	56.	70055010	REAR BRG CUP (PART OF 82)	1REF
3.	60025008	CYLINDER HEAD	2	57.	60025005	REAR BRG HSG (PART OF 82)	1REF
4.	60025009	PULSATION TANK	1	58.	70014583	COIL SPRING	1
5.	70073031	VALVE PLATE	2	59.	60101505	SLEEVE	1
6.	70073030	DIPSTICK	1	60.	70051006	OIL PUMP	1
7.	70014613	DIPSTICK TUBE	1	61.	60025006	PUMP COVER	1
8.	60120238	OIL SCREEN TUBE (PART OF 83)	1REF	63.	72053411	PLUG 1/8NPT SQHD	2
9.	60120289	OIL SCREEN (PART OF 83)	1REF	64.	72060731	SCR 5/16-18X3/4 SH (PART OF 83)	5REF
10.	72066008	OIL SCREEN CLAMP (PART OF 83)	1REF	65.	72060731	SCR 5/16-18X3/4	4
11.	60101507	OIL FILL PIPE	1	66.	51029296	CONNECTING ROD	4
12.	51705310	BREATHER CAP ASM (INCL:89,90)	1	67.	70029062	PISTON (PART OF 88)	4REF
13.	76393085	O-RING (PART OF 44&77)	1REF	68.	70014627	PISTON PIN (PART OF 88)	4REF
14.	72053403	PLUG 3/8NPT SH (PART OF 83)	1REF	69.	72066018	RETAINING RING (PART OF 88)	8REF
15.	72053413	PLUG 3/8NPT SQHD (PAR OF 83)	1REF	70.	70014600	OIL RING (PART OF 87)	4REF
16.	70039300	IDENT PLATE	1	71.	70014599	COMPRESSION RING(PART OF 87)	8REF
17.	70014626	AIR FILTER CLIP	8	73.	76039093	PUMP COVER GASKET	1
18.	76039141	AIR INTAKE FILTER-FOAM	2	74.	76039112	FRT BRG HSG GASKET (PART OF 83)	2REF
19.	73054026	DRAIN COCK	1	75.	72063050	WASHER 5/16 LOCK	1
20.	72053406	PLUG 1NPT SH	1	76.	72053404	PLUG 1/2NPT SH	1
21.	72060032	CAP SCR 5/16-18X2-3/4	12	77.	70029593	INSERT (PART OF 44)	1REF
22.	72060062	CAP SCR 7/16-14X1	4	78.	7Q073017	O-RING (PART OF 44)	1REF
23.	72060025	CAP SCR 5/16-18X1 HHGR5	12	79.	51704827	MANIFOLD CHECK VALVE ASM (INCL:32,36,37,41-44,77,78)	1
24.	72063001	WASHER 1/4 WRT	12	81.	51705709	FRT BRG HSG ASM (INCL:47-49,PART OF 83)	1REF
25.	70024122	WASHER 5/16 FLAT COPPER	12	82.	51705710	REAR BRG HSG ASM (INCL:56,57,PART OF 83)	1REF
26.	72063052	WASHER 7/16 LOCK	4	83.	51705811	CRANKCASE/CRANKSHAFT ASM	1
28.	7Q072212	O-RING	2	84.	51704321	CRANKSHAFT ASM (INCL:50,51,53-55,PART OF 83)	1REF
29.	76039113	HEAD GASKET	2	85.	72063050	WASHER 5/16 LOCK (PART OF 83)	5REF
30.	76039114	GASKET-CYL BLOCK/VLV PLT	2	86.	72060025	CAP SCR 5/16-18X1(PART OF 83)	5REF
31.	76039111	GASKET-CRNCASE/CYL BLOCK	2	87.	51014947	RING SET (INCL:70,71)	1
32.	60025229	MANIFOLD BLOCK (PART OF 79)	1REF	88.	51029285	PISTON ASM (INCL:67-69)	4
33.	76393802	FILTER SCREEN	4	89.	60107276	CAP 1/2HEX MOD (PART OF 12)	1REF
36.	72053404	PLUG 1/2NPT SH(PART OF 79)	1REF	90.	70048080	BREATHER 1/4NPT (PART OF 12)	1REF
37.	72053405	PLUG 3/4NPT SH (PART OF 79)	1REF	91.	70039124	OIL FILL DECAL	1
38.	72053558	NIPPLE 3/4NPT X 2	1	92.	70056437	PULLEY 1-GROOVE 5/8"	1REF
39.	72053376	RED. BUSHING 3/4FPT 1MPT	1		70056304	PULLEY 2-GROOVE 1/2"	1REF
40.	72053295	STREET ELBOW 3/4NPT 90°	1		70056441	PULLEY 6-GROOVE SERPENTINE	1REF
41.	60106933	PLUG 3/4MPT (PART OF 79)	1REF		70056442	PULLEY 7-GROOVE SERPENTINE	1REF
42.	72066426	BALL 9/16 (PART OF 44)	1REF	93.	77044419	CLUTCH FIELD	1
43.	76393107	O-RING (PART OF 79)	1REF	94.	72066537	J-CLIP .19 VINYL	2
44.	51704023	INSERT ASM	1REF	95.	70732444	CLUTCH HARDWARE KIT	1
45.	72661487	DRIVE PIN	1	100.	70029468	SHIM (PART OF 44)	1REF
47.	76039119	SEAL (PART OF 81)	1REF	101.	76039092	REAR BRG GASKET .006	AR
48.	60025007	FRT BRG HSG (PART OF 81)	1REF		76039094	REAR BRGGASKET .010	AR
49.	70055011	FRT CUP BEARING (PART OF 81)	1REF		76039143	REAR BRG GASKET .015	AR
50.	70055012	FRT CONE BEARING (PART OF 84)	1REF		76039144	REAR BRG GASKET .020	AR
51.	60101271	CRANKSHAFT	1				
52.	72066267	WOODRUFF KEY #6	1				
53.	70055009	REAR CONE BRG (PART OF 84)	1REF				
54.	60101269	OIL PUMP COLLAR	1REF				

**FIGURE D-2A. DA425EA UNDERHOOD AIR COMPRESSOR (51711330-2)**

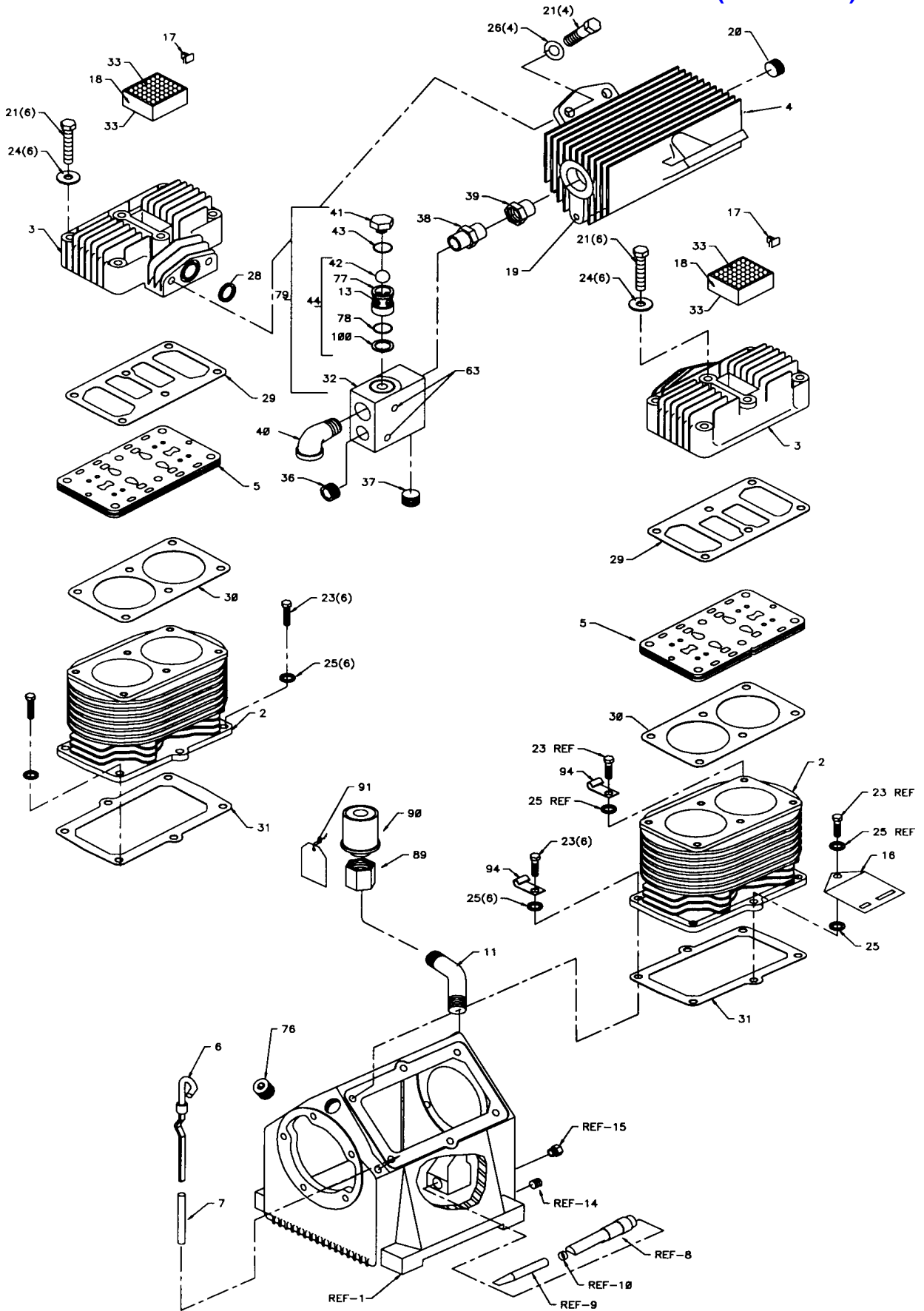

**FIGURE D-2B. DA425EA UNDERHOOD AIR COMPRESSOR (51711330-3)**

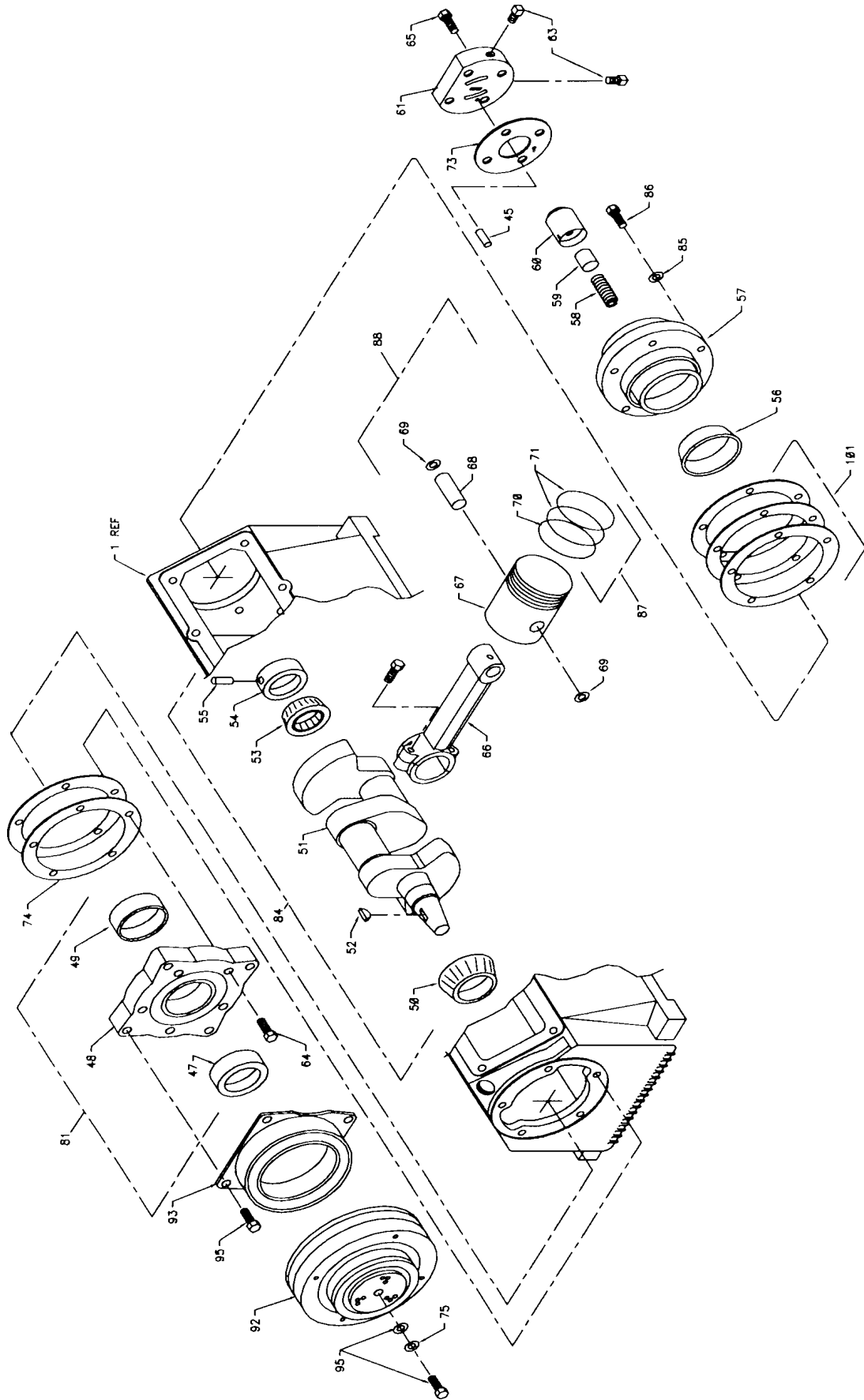

**REMOTE MOUNTED PRESSURE SWITCH  
INSTALLATION INSTRUCTIONS (99900501)**

1. Locate pressure switch mounting bracket (60119843) to the firewall or fender well of truck. Use the predrilled holes on the mounting bracket as a pattern to drill holes when mounting.
2. Assemble pressure switch and related hardware to the mounting bracket. Attach a 90° brass elbow (72531042) to the bottom side of the pressure switch mounting bracket.
3. Mount the pressure switch mounting bracket to the truck. Use the three (2) sheet metal screws provided in the kit.

4. Install the 1/8-1/4 adapter (72053832) in the check valve block and attach the 1/4" airline hose.
5. Continue assembly as shown on the installation assembly drawing.
6. See Electrical Wiring Diagram provided with the Pressure Switch Kit, for hook-up information.

**NOTE**

ON FORD LATE MODEL TRUCKS, MOUNTING BRACKET (60119843) CAN BE LOCATED ON THE PASSENGER SIDE OF THE RADIATOR AT TOP. USE EXISTING BOLTS.

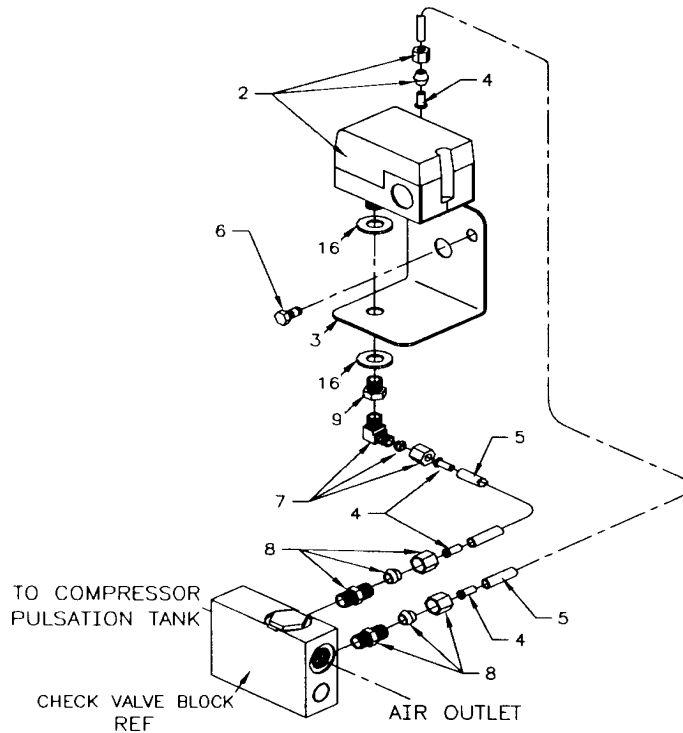

ITEM	PART NO.	DESCRIPTION	QTY	ITEM	PART NO.	DESCRIPTION	QTY
1.	51710224	KIT-RMT PR SW (INCL:2-17)	1	10.	89044274	WIRE 14GA BLK (4 FT)	REF
2.	77041369	PRESSURE SWITCH	1REF	11.	89044271	WIRE 14GA BLU (4 FT)	REF
3.	60119843	MOUNTING BRACKET	1REF	12.	89044234	WIRE 14GA YEL (4 FT)	REF
4.	72532952	BRASS INSERT	4REF	13.	77040051	TERMINAL SPADE 16-14GA	3REF
5.	89034176	AIR LINE 1/4" (10 FT)	REF	14.	89034048	SPIRAL WRAP (7")	REF
6.	72061004	SHT MTL SCR #14X3/4	2REF	15.	89034176	AIR LINE 1/4" (5 FT)	REF
7.	72531042	ELBOW 1/8-1/4NPT 90°	1REF	16.	72063005	WASHER 1/2 WRT	2REF
8.	72053832	ADAPTER 1/8MPT 1/4CPRSNTG	2REF	17.	99900169	WIRING DIAG-COMPRESSOR	1REF
9.	72531826	REDUCER BUSHING 1/4-1/8NPT	1REF				

**FIGURE D-3. PRESSURE SWITCH KIT & INSTALLATION INSTRUCTIONS (51710224)**

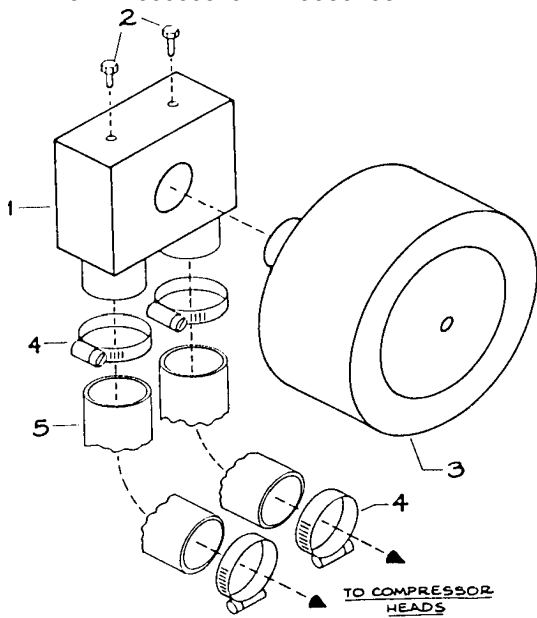

ITEM	PART NO.	DESCRIPTION	QTY
1.	51707706	AIR INTAKE MANIFOLD ASM	1
2.	72061004	SHT MTL SCR #14X3/4	2
3.	70048007	SOLBERG FILTER	1
4.	72066001	HOSE CLAMP #24	4
5.	76391332	HOSE	2

**FIGURE D-4. OPTION-SOLBERG AIR FILTER KIT (51709435)**

<b>REPAIR KITSGASKET KIT - 51039013</b>		
7Q072212	O-RING - CYL HEAD	2
76039092	GASKET-REAR BRG HSG .006	2
76039093	GASKET-PUMP COVER	1
76039094	GASKET-REAR BRG HSG .010	2
76039111	GASKET-CYL BLOCK BOTTOM	2
76039112	GASKET-FRT BRG HSG	2
76039113	GASKET-VALVE COVER	2
76039114	GASKET-CYL BLOCK TOP	2
76039119	SEAL	1
76039143	GASKET-REAR BRG HSG .015	2
76039144	GASKET-REAR BRG HSG .020	2
<b>CHECK VALVE KIT - 51704358</b>		
7Q073017	O-RING	1
70029377	CHECK VALVE INSERT	1
70029468	SHIM .53 ID X .94 OD X .005 THK	1
72066426	BALL .594 DIA	1
76393085	O-RING	1
<b>CRANKSHAFT KIT - 51070708</b>		
51705655	CRANKSHAFT ASM (INCL: KEY & CRANK)	1
70055010	BEARING-REAR CUP	1
70055011	BEARING-FRT CUP	1
70055012	BEARING-FRT CONE	1
70055009	BEARING-REAR CONE	1
72066307	DRIVE PIN	1
60101269	OIL PUMP COLLAR	1
<b>PISTON RING SET - 51014947</b>		
70014599	COMPRESSION RING	8
70014600	OIL RING	4

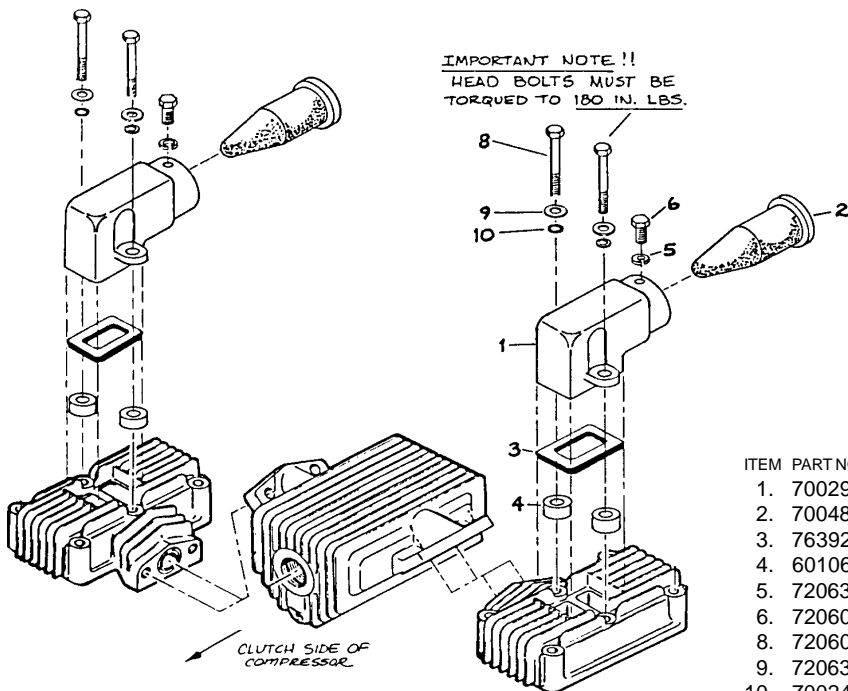

ITEM	PART NO.	DESCRIPTION	QTY
1.	70029546	BREATHER MANIFOLD	2
2.	70048117	AIR FILTER CONE	2
3.	76392274	GASKET	2
4.	60106236	SLEEVE	4
5.	72063049	WASHER 1/4 LOCK	2
6.	72060270	CAP SCR 1/4-28X1/2 HHGR5	2
8.	72060035	CAP SCR 5/16-18X3-1/2 HHGR5	4
9.	72063001	WASHER 1/4 FLAT	4
10.	70024122	WASHER .33X.50X.03 COPPER	4

**FIGURE D-5. OPTION-AIR FILTER KIT (95709998)**

## SECTION 5. REPAIR

### 5-1. GENERAL

This section describes the disassembly and assembly procedures for the air compressor. In all cases, remove the compressor from the frame, and provide a clean work environment before proceeding with disassembly. Refer to the parts drawing in section 4 of this manual for parts locations.

### 5-2. PISTON RING REPLACEMENT

1. Remove the pulsation tank.
2. Unscrew the head bolts and remove the heads.

**NOTE**

A RUBBER FACED Mallet WILL HELP WHEN REMOVING THE HEAD. TAP THE SIDES OF THE HEAD CAREFULLY UNTIL THE HEAD IS LOOSE. LIFT OFF THE HEADS.

3. Remove the cylinder bolts. Tap the sides of the cylinder several times to break it loose from the gasket. Rock the cylinder back and forth and lift until it is free. Lift it off the pistons.

4. Use a single edged razor blade, or sharp putty knife, to remove the old gasket material.

**CAUTION**

DO NOT ALLOW THE GASKET MATERIAL TO FALL INTO THE CRANKCASE. DO NOT NICK THE HEAD, CYLINDER, OR CRANKCASE MATING FACES WHILE REMOVING THE OLD GASKET. REMOVE ALL OF THE OLD GASKET MATERIAL TO PROVIDE A SMOOTH, CLEAN SURFACE FOR THE NEW GASKET. FAILURE TO FOLLOW THIS PROCEDURE MAY RESULT IN THE NEED TO RESEAL THE UNIT LATER.

5. Hone the cylinder to break the glaze and to remove the buildup at the top of the cylinders.
6. Measure the inside diameter of the cylinder for roundness and excessive wear. The bore should be 2.625" (0.0025" tolerance). If the bore is oversized, the cylinder must be replaced.
7. With a ring expander, remove the compression and oil rings.
8. With the ring expander, install the new ring kit. Make certain that the oil ring is on the bottom and the beveled inside edge of the compression ring is toward the top of the piston.

9. Position the cylinder base gasket on the crankcase. Use a few drops of oil to hold it in position. Install the cylinder block spacer and gasket on the crankcase.

10. Rotate the rings so that the gaps of the three rings are 120° apart. Lightly lubricate the inside of the cylinder. Rotate the crankshaft so that a piston is at the top of the stroke. Compress the rings with a ring compressor, and slide the cylinder over the piston. Repeat for the other piston.

**CAUTION**

DO NOT LUBRICATE THE RINGS. USE A LIGHT LUBRICANT, SUCH AS WD-40 ONLY, ON THE CYLINDER WALLS. OILING THE RINGS WILL PREVENT THEM FROM SEATING AND CAUSE EXCESSIVE OIL CONSUMPTION.

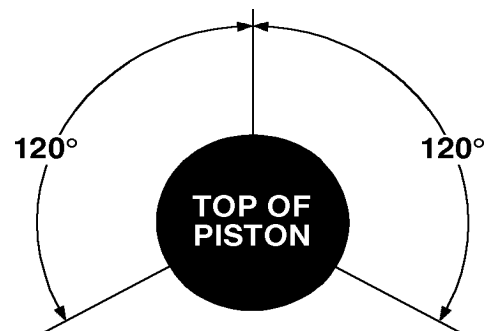

**FIGURE E-1. PISTON RING ORIENTATION**

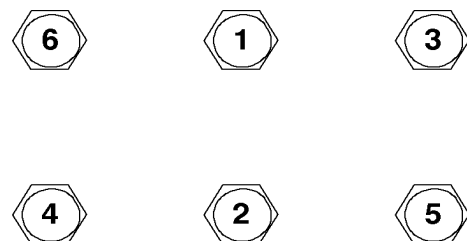

**FIGURE E-2. CYL HEAD TORQUE SEQUENCE**

DA425EA:99900679: 19951003

11. Slide the cylinder down until it mates with the crankcase. Start all cylinder mounting bolts, until they are snug. Torque the bolts to 180 inch pounds in the sequence shown. Do not torque to the full 180 inch pounds all at once. Torque in 25-50 pound increments.

12. Position the gaskets and valve plate on top of the cylinder. Position the head on the cylinder and turn all studs finger tight. Torque the studs/nuts to 240 in-lbs in 25-50 pound increments

**NOTE**

INSTALL THE VALVE PLATE WITH THE MARKED SURFACE FACING UP.

13. Install the pulsation tank, and torque to 180 inch-pounds.

14. Install the compressor, connect the wiring and the air lines. Test the unit.

**NOTE**

IF PRESSURE FAILS TO BUILD AND THE COMPRESSOR IS EXCESSIVELY NOISY, CHECK THE VALVE PLATE. IT MAY HAVE BEEN INSTALLED UPSIDE DOWN.

### 5-3. OIL PUMP REPLACEMENT

1. Remove the bolts and lift off the pump cover.
2. With a single edged razor blade, or sharp putty knife, remove the old gasket material. Take care not to damage the machined surfaces.
3. Lift the pump out of the cavity.
4. Position a new gasket on the rear bearing housing.
5. Insert the pump into the cavity. Position the pump slightly to one side, using a common screwdriver. Wedge the pump into position so that it partially compresses the spring. Note that the driver pin and slot in pump must be in line.
6. Place the pump cover into position and start two bolts (bolts must be diagonally opposed). Strike the pump cover with a rubber faced mallet to jar the pump loose. When the tension spring can be felt against the pump cover, the pump is loose.

5-2

7. Insert the two remaining bolts and torque to 180 inch-pounds. The bolts should be torqued in a diagonal pattern.

8. Install the air compressor On the frame. Connect the air lines and wiring.

### 5-4. CRANKSHAFT AND BEARING REPLACEMENT

If it is necessary to replace the crankshaft, related components must also be replaced. Replace both bearings, both races, the key, pump collar and pump drive pin.

**NOTE**

DEPENDING ON THE CONDITION OF THE CRANKSHAFT, BEARING MAY BE REPLACED WITHOUT REPLACING THE CRANKSHAFT. REPLACE THE BEARING RACES WHENEVER THE BEARINGS ARE REPLACED.

1. Remove the pulsation tank, both heads, cylinders, and pistons. Refer to the instructions in section 5, paragraph 2.
  2. Remove the bolts on the connecting rods, and lift them out. Reassemble the connecting rods to be certain that the matched parts remain together on the same crankshaft journals.
  3. Remove the pump cover, oil pump, sleeve, spring, and rear bearing housing.
  4. Remove the clutch and pulley assembly, and the front bearing housing.
  5. Pull the crankshaft from the crankcase.
  6. Remove all gasket material with a single edged razor blade, or sharp putty knife.
- CAUTION**
- DO NOT GOUGE THE MACHINED SURFACES WHEN REMOVING THE GASKETS. THIS MAY CAUSE LEAKS.
7. Press the bearing races out of the bearing housing.
  8. Press the tapered roller bearings off of the crankshaft if only the bearings are being replaced. If the crankshaft is to be replaced, discard the entire assembly.
  9. Press the new bearings into position.



**NOTE**

THE CRANKSHAFT SHOULD HAVE NEW BEARINGS INSTALLED. IF NOT, PRESS THE NEW BEARINGS INTO POSITION ON THE CRANKSHAFT.

10. Generously oil the front bearing race and install the front bearing housing with gasket. Torque the bolts to 180 inch- pounds. Torque the bolts as shown in the pattern below.

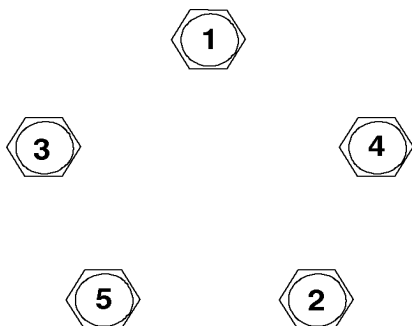

**FIGURE E-3. BRG HSG TORQUE SEQUENCE**

11. Slide the crankshaft into the crankcase. Generously lubricate the bearing race and install the rear bearing housing and gaskets.

**NOTE**

GASKET KITS ARE SUPPLIED WITH TWO (2) EACH OF .006, .010, .015, AND .020 GASKETS. USE THESE REAR BEARING GASKETS IN ANY COMBINATION AND QUANTITY TO LIMIT ALL PLAY FRONT TO REAR, BUT STILL ALLOW THE CRANKSHAFT TO TURN FREELY.

12. Install the oil pump as indicated in section 5, paragraph 3.

13. Install the connecting rods. Thoroughly oil the crankshaft and rods before installing them. When installing the rods, make certain that the tabs are aligned on the same side of the rod as shown below.

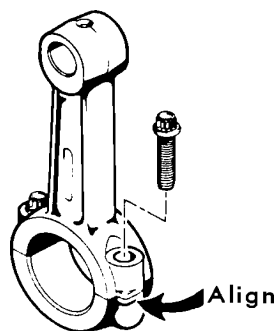

**FIGURE E-4. ROD ALIGNMENT**

14. Install the pistons, rings, heads and pulsation tank.

**5-5. CLUTCH REPLACEMENT**

**CAUTION**

CLUTCH FAILURE MAY BE DUE TO A LEAKING CHECK VALVE. MAKE CERTAIN THAT THE CHECK VALVES ARE FUNCTIONING PROPERLY BEFORE INSTALLING THE NEW CLUTCH. THE CHECK VALVES MAY BE CHECKED BY PRESSURIZING THE TANK AND SHUTTING OFF THE COMPRESSOR. THERE SHOULD BE NO AIR ESCAPING FROM THE UNLOADER VALVE. IF THERE IS AIR ESCAPING, THE CHECK VALVES ARE FAULTY.

The clutch assembly can be removed while the compressor is still on the vehicle. The following procedure should be used.

**WARNING**

ATTEMPTING TO START THE COMPRESSOR WHILE THE CLUTCH IS BEING REMOVED WILL CAUSE SERIOUS INJURY.

1. Turn on the ignition switch, and move the compressor switch to the on position. This will engage the clutch, and make for easier removal.
2. Remove the bolt in the center of the pulley and insert a 5/8-11 bolt.
3. Tighten the 5/8-11 bolt until the pulley is forced off the crankshaft.
4. Loosen the drive belt and remove the pulley.

**NOTE**

IF THE DRIVE BELT IS LOOSE, IT WILL BE DIFFICULT TO HOLD THE PULLEY STATIONARY WHILE TIGHTENING THE 5/8-11 BOLT.

**CAUTION**

DO NOT USE A WHEEL PULLER ON THE OUTER RIM OF THE PULLEY. THIS CAN RESULT IN DAMAGE TO THE CLUTCH BEARING.

5. Remove the four (4) bolts holding the coil assembly to the front of the compressor.

To reinstall the clutch:

1. Position the magnetic coil assembly over the front bearing housing and secure the assembly with the 1/4-20 bolts. Torque to 85-120 inch-pounds.
2. Insert the woodruff key into the crankshaft slot.
3. Slide the pulley, spacer, and lock washer onto the end of crankshaft. Be certain that the pulley slot aligns with the woodruff key. Secure them with the 5/16-18 bolts.
4. Rotate the pulley assembly manually to check for interference between the pulley and the coil. If there is interference, disassemble the clutch and repeat the procedure.
5. Install and tighten the drive belts.
6. Connect the coil wire to the air pressure switch.
7. Move the compressor switch in the cab to the on position to activate the clutch. Tighten the center bolt in the pulley.
8. Test the unit for proper operation.

**5-6. TROUBLESHOOTING**

SYMPTOM	PROBABLE CAUSE
<b>LOW OIL PRESSURE</b>	LOW OIL LEVEL
	LOOSE PIPE PLUG ON OIL PUMP COVER
	WORN OR DEFECTIVE OIL PUMP
	CRACK OR SCRATCH ON OILPUMP COVER
<b>NO OIL PRESSURE</b>	DEFECTIVE OIL PUMP
	BLOCKED OIL PASSAGE
	DAMAGED OIL PUMP DRIVE PIN
<b>COMPRESSOR WILL NOT ENGAGE</b>	VEHICLE HOOD CLOSED
	BLOWN FUSE
	DEFECTIVE CLUTCH/BELT
	DEFECTIVE PRESSURE SWITCH
<b>COMPRESSOR ENGAGES BUT WILL NOT PRESSURIZE TANK</b>	AIR LEAK IN PLUMBING
	WORN PISTON RINGS OR VALVE PLATES
	DEFECTIVE CHECK VALVE/VALVES
<b>COMPRESSOR DOES NOT RECOVER PRESSURE AS FAST AS IT SHOULD</b>	DEFECTIVE CHECK VALVE/VALVES
	DIRTY FILTERS
	LOOSE BELT
	AIR LEAK IN PLUMBING
	WORN VALVE PLATES OR PISTON RINGS

**FIGURE E-5. TROUBLESHOOTING CHART**

The information within this manual has been compiled and checked but errors do occur. To provide our customers with a method of communicating those errors we have provided the Manual Change Request form below. In addition to error reporting, you are encouraged to suggest changes or additions to the manual which would be of benefit to you. We cannot guarantee that these additions will be made but we do promise to consider them. When completing the form, please write or print clearly. Submit a copy of the completed form to the address listed below.

## MANUAL CHANGE REQUEST

DATE	PRODUCT MANUAL	MANUAL PART NO.
SUBMITTED BY		
COMPANY		
ADDRESS		
CITY, STATE, ZIP		
TELEPHONE		

ERROR FOUND

LOCATION OF ERROR (page no.): \_\_\_\_\_

DESCRIPTION OF ERROR: \_\_\_\_\_

---



---



---



---



---



---



---



---



---



---

REQUEST FOR ADDITION TO MANUAL

DESCRIPTION OF ADDITION: \_\_\_\_\_

---



---



---

REASON FOR ADDITION: \_\_\_\_\_

---



---



---

MAIL TO: IOWA MOLD TOOLING Co., Inc.  
Box 189,  
Garner IA 50438-0189  
ATTN: Technical Publications

## LIMITED WARRANTY

**WARRANTY COVERAGE** - Products manufactured by Iowa Mold Tooling Co., Inc. (IMT) are warranted to be free from defects in material and workmanship, under proper use, application and maintenance in accordance with IMT's written recommendations, instructions and specifications as follows:

1. Ninety (90) days; labor on IMT workmanship from the date of shipment to the end user.
2. One (1) year; original IMT parts from the date of shipment to the end user.

IMT's obligation under this warranty is limited to, and the sole remedy for any such defect shall be the repair or replacement (at IMT's option) of unaltered parts returned to IMT, freight prepaid, and proven to have such defect, provided such defect occurs within the above stated warranty period and is reported within fourteen (14) days of its occurrence.

**IMPLIED WARRANTY EXCLUDED** - This is the only authorized IMT warranty and is in lieu of all other express or implied warranties or representations, including any implied warranties of merchantability or fitness for any particular purpose or of any other obligations on the part of IMT.

**ITEMS EXCLUDED** - The manufacturer gives no warranty on any components purchased by the manufacturer, and such components as are covered only by the warranties of their respective manufacturers.

**WARRANTY CLAIMS** - Warranty claims must be submitted and shall be processed in accordance with IMT's established warranty claim procedure.

**WARRANTY SERVICE** - Warranty service will be performed by any IMT distributor authorized to sell new IMT products of the type involved or by any IMT Service Center authorized to service the type of product involved or by IMT in the event of direct sales made by IMT. At the time of requesting warranty service, the purchaser must present evidence of the date of delivery of the product. The purchaser shall pay any premium for overtime labor requested by the purchaser, any charge for making service calls and for transporting the equipment to the place where warranty work is performed.

**WARRANTY VOIDED** - All obligations of IMT under this warranty shall be terminated: (1) if service other than normal maintenance or normal replacement of service items is performed by someone other than an authorized IMT dealer, (2) if product is modified or altered in ways not approved by IMT.

**PURCHASER'S RESPONSIBILITY** - This warranty covers only defective material and workmanship. It does not cover depreciation or damage caused by normal wear, accident, improper protection in storage, or improper use. The purchaser has the obligation of performing the care and maintenance duties discussed in IMT's written recommendations, instructions and specifications. Any damage which results because of purchaser's failure to perform such duties shall not be covered by this warranty. The cost of normal maintenance and normal replacement of service items such as filters, belts, etc. shall be paid by the purchaser.

**CONSEQUENTIAL DAMAGES** - The only remedies the purchaser has in connection with the breach or performance of any warranty on IMT products are those set forth above. In no event will the dealer, IMT or any company affiliated with IMT, be liable for business interruptions, loss of sales and/or profits, rental or substitute equipment, costs of delay or for any other special, indirect, incidental or consequential losses, costs or damages.

**REPRESENTATIONS EXCLUDED** - IMT products are subject to no expressed, implied or statutory warranty other than herein set forth, and no agent, representative or distributor of the manufacturer has any authority to alter the terms of this warranty in any way whatsoever or to make any representations or promises, express or implied, as to the quality or performance of IMT products other than those set forth above.

**CHANGE IN DESIGN** - IMT reserves the right to make changes in design or improvements upon its products without imposing any obligation upon itself to install the same upon its products theretofore manufactured.

Effective January, 1985

This parts manual is provided to the user to assist in servicing the equipment. It is the property of Iowa Mold Tooling Co., Inc and, as such, may not be reproduced either whole or in part, whether by chemical, electrostatic, mechanical or photographic means without the expressed written permission of an officer of Iowa Mold Tooling Co., Inc. One manual is provided with each piece of new equipment and additional manuals may be obtained at a nominal price.



**IOWA MOLD TOOLING CO., INC.**  
 BOX 189, GARNER, IA 50438-0189  
 TEL: 515-923-3711  
 TECHNICAL SUPPORT FAX: 515-923-2424