



---

# MATERIAL HANDLING SYSTEMS

## CRANE SPECIFICATIONS & OPERATION MANUAL

*MODELS 0.5/4, 1.5/10, 2.0/15T, 2.6/19T*

**IOWA MOLD TOOLING CO., INC.**

BOX 189, GARNER, IA 50438-0189  
641-923-3711

**MANUAL PART NO: 99903422**

Iowa Mold Tooling Co., Inc. is an Oshkosh Corporation Ccompany.

## TABLE OF CONTENTS

<b>1.0 CRANE DESCRIPTION</b> .....	<b>5</b>
<b>MODEL 0.5/4</b> .....	<b>5</b>
<b>MODEL 1.5/10, 2.0/15T, 2.6/19T</b> .....	<b>6</b>
<b>2.0 OPERATING INSTRUCTIONS</b> .....	<b>7</b>
<b>2.1 START UP</b> .....	<b>7</b>
<b>2.1.1 STABILIZER SET-UP (IF APPLICABLE)</b> .....	<b>7</b>
<b>2.2.2 STARTING THE HYDRAULIC SYSTEM</b> .....	<b>8</b>
<b>2.3 FOLDING / UNFOLDING THE CRANE</b> .....	<b>8</b>
<b>2.4 SAFE DISTANCES TO ELECTRICAL WIRES</b> .....	<b>9</b>
<b>2.5 ATTACHING THE LOAD</b> .....	<b>9</b>
<b>2.6 LOADER REACH &amp; CAPACITY</b> .....	<b>9</b>
<b>2.6.1 MODEL 0.5/4 CAPACITY CHART</b> .....	<b>10</b>
<b>2.6.2 MODEL 1.5/10 CAPACITY CHART</b> .....	<b>10</b>
<b>2.6.4 MODEL 2.0/15T CAPACITY CHART</b> .....	<b>11</b>
<b>2.6.5 MODEL 2.6/19T CAPACITY CHART</b> .....	<b>11</b>
<b>2.7 CRANE OPERATION</b> .....	<b>12</b>
<b>2.7.1 OPERATION - MODEL 0.5/4</b> .....	<b>12</b>
<b>2.7.2 OPERATION - MODELS 1.5/10, 2.0/15T &amp; 2.6/19T</b> .....	<b>12</b>
<b>4.0 HYDRAULIC SAFETY SYSTEM</b> .....	<b>13</b>
<b>4.1 MODEL 1.5/10, 2.0/15T, 2.6/19T HYDRAULIC SAFETY SYSTEM</b> .....	<b>13</b>
<b>4.3 MODEL 1.5/10 ELECTRO-HYDRAULIC DIAGRAM</b> .....	<b>14</b>
<b>4.3.2 MODEL 1.5/10 HYDRAULIC DIAGRAM</b> .....	<b>15</b>
<b>4.3.3 MODEL 2.0/15T ELECTRO-HYDRAULIC DIAGRAM</b> .....	<b>16</b>
<b>4.3.4 MODEL 2.0/15T HYDRAULIC DIAGRAM</b> .....	<b>17</b>
<b>4.3.5 MODEL 2.6/19T ELECTRO-HYDRAULIC DIAGRAM</b> .....	<b>18</b>
<b>4.3.6 MODEL 2.6/19T HYDRAULIC DIAGRAM</b> .....	<b>19</b>
<b>5.0 MAINTENANCE</b> .....	<b>20</b>
<b>5.1 MODEL 0.5/4 - DAILY MAINTENANCE POINTS</b> .....	<b>20</b>
<b>5.2 MODEL 1.5/10, 2.0/15T, 2.6/19T - DAILY MAINTENANCE POINTS</b> .....	<b>21</b>
<b>6.0 LUBRICATION &amp; OIL CHANGE</b> .....	<b>22</b>
<b>6.1 MODEL 1.5/10, 2.0/15T, 2.6/19T GREASE ZERK LOCATIONS</b> .....	<b>22</b>
<b>6.3 CHANGING THE OIL AND OIL FILTER</b> .....	<b>23</b>
<b>6.3.1 MODEL 1.5/10, 2.0/15T, 2.6/19T - CHANGING THE OIL &amp; OIL FILTER BY THE ELECTRIC POWER PACK</b> .....	<b>23</b>
<b>6.3.2 MODEL 1.5/10, 2.0/15T, 2.6/19T - CHANGING THE OIL &amp; OIL FILTER BY PTO-HYDRAULIC</b> .....	<b>23</b>
<b>6.3.4 HYDRAULIC OIL &amp; GREASE SPECIFICATIONS</b> .....	<b>24</b>
<b>7.0 BLEEDING AIR FROM CYLINDERS</b> .....	<b>25</b>
<b>7.1 MODEL 1.5/10, 2.0/15T, 2.6/19T</b> .....	<b>25</b>
<b>7.3 ACCESSORIES (MODELS 1.5/10, 2.0/15T, 2.6/19T ONLY)</b> .....	<b>26</b>
<b>8.0 CHANGE OF SLEWING AREA</b> .....	<b>27</b>
<b>8.1 MODEL 1.5/10, 2.0/15T, 2.6/19T CHANGE OF SLEWING AREA</b> .....	<b>27</b>
<b>9.0 TECHNICAL DATA</b> .....	<b>28</b>
<b>9.1A MODEL 0.5/4 DIMENSIONAL DRAWINGS</b> .....	<b>28</b>
<b>9.1B MODEL 0.5/4 TECHNICAL DATA</b> .....	<b>29</b>

## TABLE OF CONTENTS, CONTINUED

9.2A MODEL 1.5/10 T1 (T2) DIMENSIONAL DRAWINGS .....	30
9.2B MODEL 1.5/10 T1 M (T2 M) DIMENSIONAL DRAWINGS .....	31
9.2C MODEL 1.5/10 TECHNICAL DATA .....	32
9.2D POWER CONSUMPTION / PUMP PERFORMANCE .....	32
9.4A: DIMENSIONAL DRAWING, 2.0/15T .....	33
9.4B: DIMENSIONAL DRAWING, 2.0/15T STATIONARY MOUNT .....	34
9.4C: 2.0/15T TECHNICAL DATA .....	35
9.5A: DIMENSIONAL DRAWING, 2.6/19T .....	36
9.5B: 2.6/19T TECHNICAL DATA .....	37
11.0 REPAIR .....	38

**In addition to the information presented in this manual, read and understand the IMT Crane Operator's Safety Manual before operating or performing any maintenance on your crane.**

## REVISIONS LIST

DATE	LOCATION	DESCRIPTION OF CHANGE
20030611	11	REVISED CAPACITY PLACARD TO INCLUDE MANUAL EXTENSION NOTE
20070228	COVER	UPDATED OWNERSHIP STATEMENT
20091120		ADDED MODEL 2.0/15T
20100414		ADDED MODEL 2.6/19T
20111129		ECN 11628 - UPDATED STABILIZER VERBIAGE, ELEC. DISTANCES
20120920		REMOVED OBSOLETE MODEL 1.7/20

### 1.0 CRANE DESCRIPTION

#### MODEL 0.5/4

- 1. BASE
- 2. MAST
- 3. LOWER BOOM
- 4. EXTENSION BOOM
- 5. HINGE PIN
- 6. CYLINDER BOLT
- 7. EXTENSION PIN
- 8. LOWER BOOM CYLINDER
- 9. ROTATION / SLEWING CRANK
- 10. HAND PUMP
- 11. PUMP LEVER
- 12. HOOK

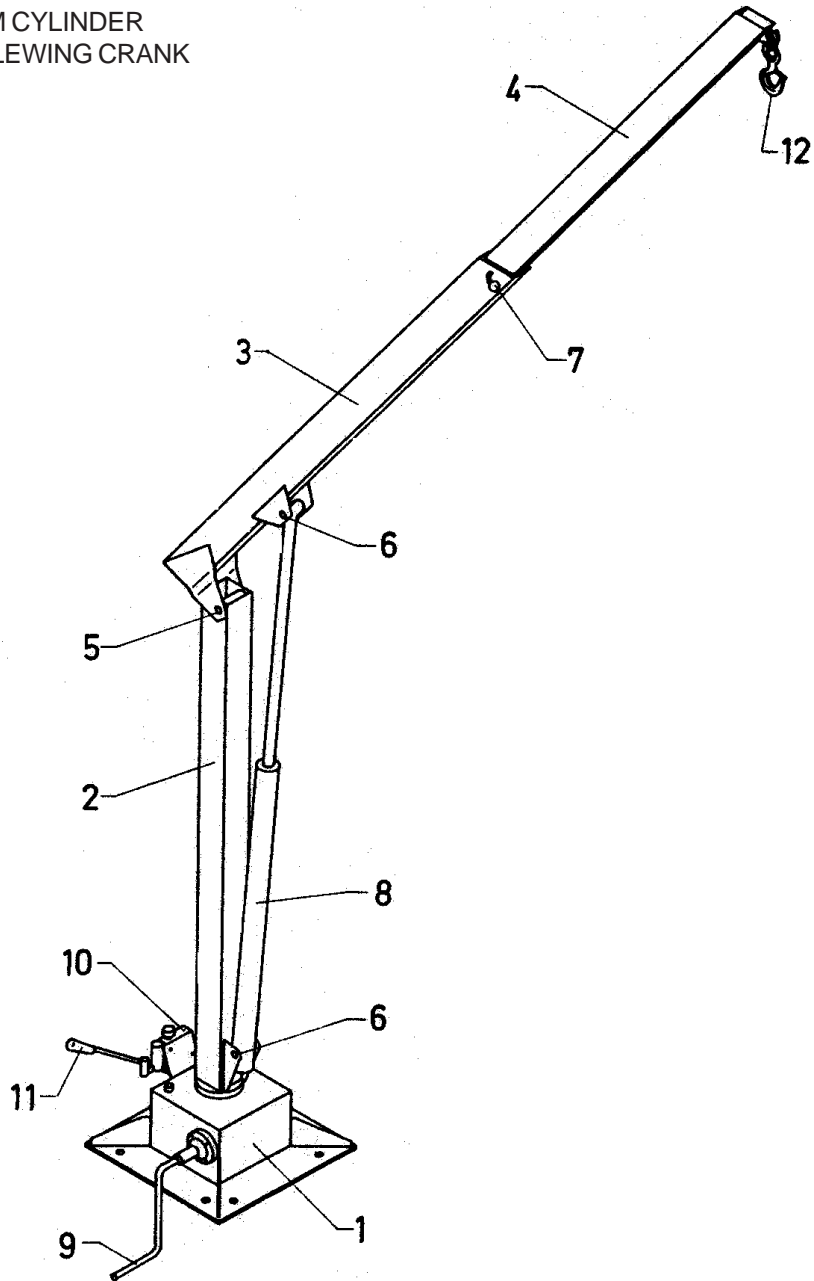

**MODEL 1.5/10, 2.0/15T, 2.6/19T**

1. BASE
2. ROTATION / SLEWING CYLINDER
3. MECHANICAL STABILIZER LEG
4. STABILIZER BEAM
5. MAST
6. LOWER BOOM CYLINDER
7. HINGE PIN
8. LOWER BOOM
9. EXTENSION CYLINDER
10. 1st EXTENSION BOOM, 100 MM (1.5/10) or 120 MM (2.0/15T or 2.6/19T)
11. 2nd EXTENSION BOOM, 83 MM (1.5/10) or 100 MM (2.0/15T or 2.6/19T)
12. HOOK
13. CONTROL VALVE BLOCK
14. MOUNTING HARDWARE

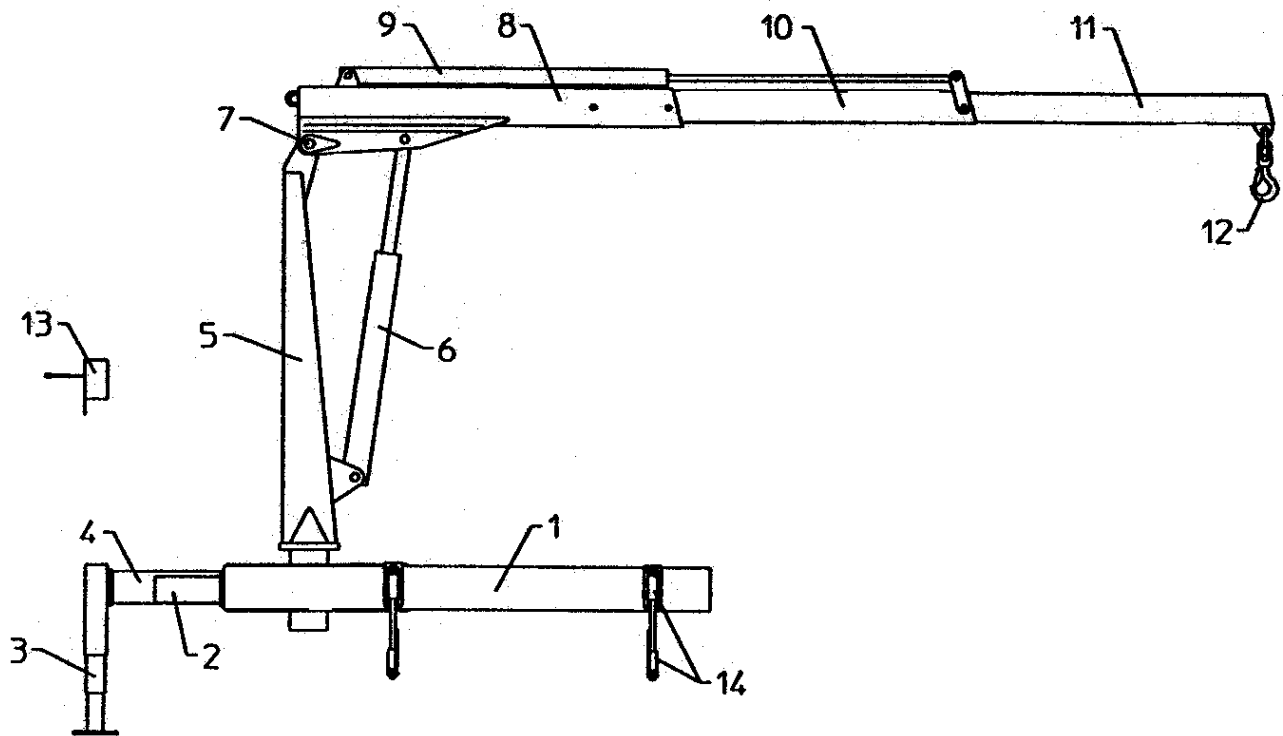

## 2.0 OPERATING INSTRUCTIONS

### 2.1 START UP

Before operating the loader:

- Set vehicle parking brake.
- Check oil levels in the tank and power pack.
- Check hoses for damage, twists, or kinks.
- Check all hooks, slings, and chains, if applicable.
- Check that manual extensions are correctly fastened with lock bolts and split pins, if applicable.
- DO NOT exceed the maximum load on manual extensions, if applicable.

#### 2.1.1 STABILIZER SET-UP (IF APPLICABLE)

##### CAUTION

NEVER OPERATE THE LOADER IF THE STABILIZERS ARE NOT LOWERED!

For proper operation, the stabilizer legs should be lowered just enough to raise the truck chassis suspension slightly. The truck, including the crane, should be parked on even ground to give a nearly perfect slew of the crane.

If the job is on soft ground, put wooden blocks or steel plates under the stabilizer legs to ensure stability. (On Model 1.5/10, the weight on the stabilizer leg can exceed 1.3 tons.)

To set-up the stabilizer leg, release the stabilizer lock and extend the stabilizer beam completely. Then, re-lock it.

If the loader is equipped with swing-up stabilizer legs, they must be vertically locked.

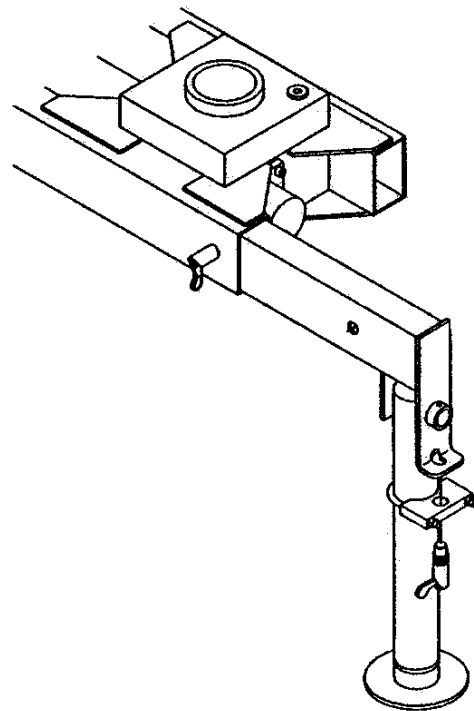

### 2.2.2 STARTING THE HYDRAULIC SYSTEM

Start the engine, disengage the clutch, and engage the PTO by pulling the handle located in the truck cab.

### 2.3 FOLDING / UNFOLDING THE CRANE

After the stabilizer leg has been lowered (if applicable), unfold the boom as shown.

**NOTE**

NEVER STAND UNDER A CRANE WHEN IT IS BEING UNFOLDED.

NEVER START UNFOLDING DURING A SLEWING MOVEMENT.

### UNFOLDING MODEL 0.5/4, 1.5/10, 2.0/15T, 2.6/10T

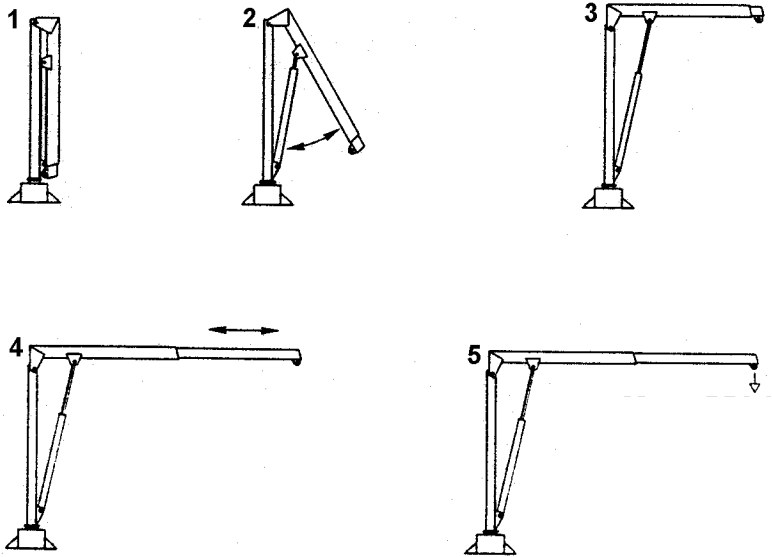



## 2.4 SAFE DISTANCES TO ELECTRICAL WIRES

	<b>NORMAL VOLTAGE kV (Phase to Phase)</b>	<b>MINIMUM REQUIRED CLEARANCE Feet (meters)</b>
<b>OPERATION NEAR HIGH VOLTAGE</b>	From 0 to 350 Over 350 or unknown	20 ( 6.10) 50 (15.24)
<b>OPERATION IN TRANSIT WITH NO LOAD AND BOOM OR MAST LOWERED.</b>	From 0 to 0.75 From 0.75 to 50 From 50 to 345 From 345 to 750 From 750 to 1000	4 ( 0.22) 6 ( 0.83) 10 ( 3.05) 16 ( 4.87) 20 ( 8.10)

## 2.5 ATTACHING THE LOAD

Attach the load and auxiliary equipment securely and carefully to the hook directly or by use of straps or chains.

## 2.6 LOADER REACH & CAPACITY

Figures for reach and capacity are shown on the capacity charts on the following pages. Your crane is designed for specific loads which are defined on the capacity placard which is mounted near the operator's station and on the crane. Exceeding the limits presented on the capacity placard will create severe safety hazards and will shorten the life of the crane. The operator and other concerned personnel must know the load capacity of the crane and the weight of the load being lifted!

### WARNING

NEVER EXCEED THE CRANE'S RATED LOAD CAPACITIES. DOING SO WILL CAUSE STRUCTURAL DAMAGE AND DAMAGE TO WINCHES AND CABLES WHICH CAN LEAD TO SERIOUS INJURIES OR DEATH.

### NOTE

LOAD LIMIT INFORMATION ON THE CAPACITY PLACARD IS FORMULATED ON 85% OF TIPPING. "TIPPING" REFERS TO THE CRANE ACTUALLY TIPPING WITH ITS OPPOSITE STABILIZER AND TIRES HAVING BROKEN CONTACT WITH THE SURFACE.

Prior to lifting a load:

1. Determine the weight of the load.
2. Determine the weight of any load handling devices.
3. Add the weight of the load and the weight of the load handling devices. The sum will be the total weight of the load being lifted.
4. Determine the distance from the centerline of crane rotation to the centerline of the load being lifted.
5. Determine the distance from the centerline of crane rotation to the centerline of where the location to which the load is to be moved.
6. The actual distance used should be figured as the larger of items 4 and 5 above.
7. Determine at what angle the crane will be operated (for example 30°, 45°, etc.) by referencing the angle indicator on the lower boom.
8. Make certain that 2-part line is used for any lift which requires 2-part line.

**2.6.1 MODEL 0.5/4 CAPACITY CHART**

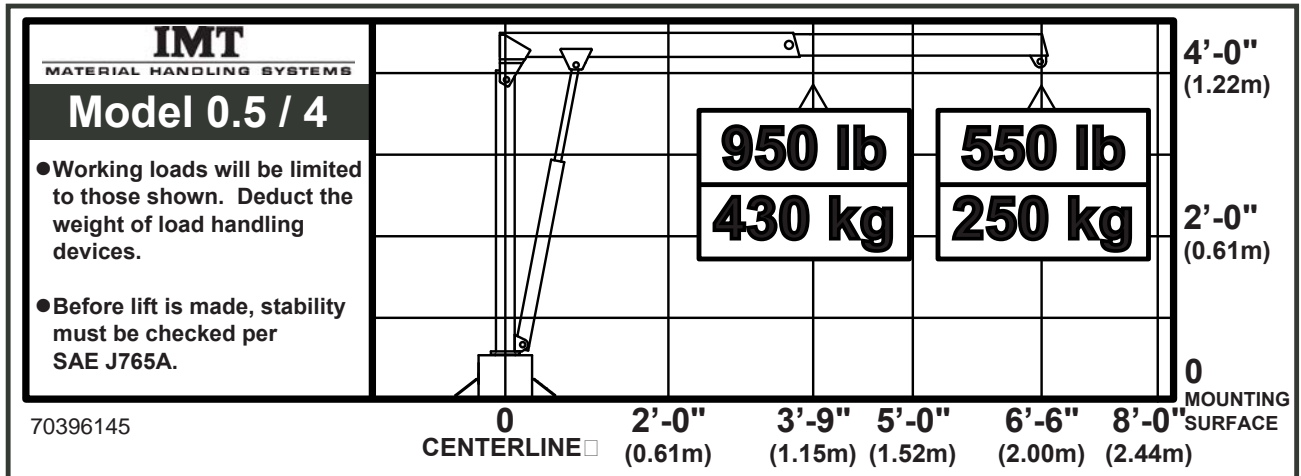

**2.6.2 MODEL 1.5/10 CAPACITY CHART**

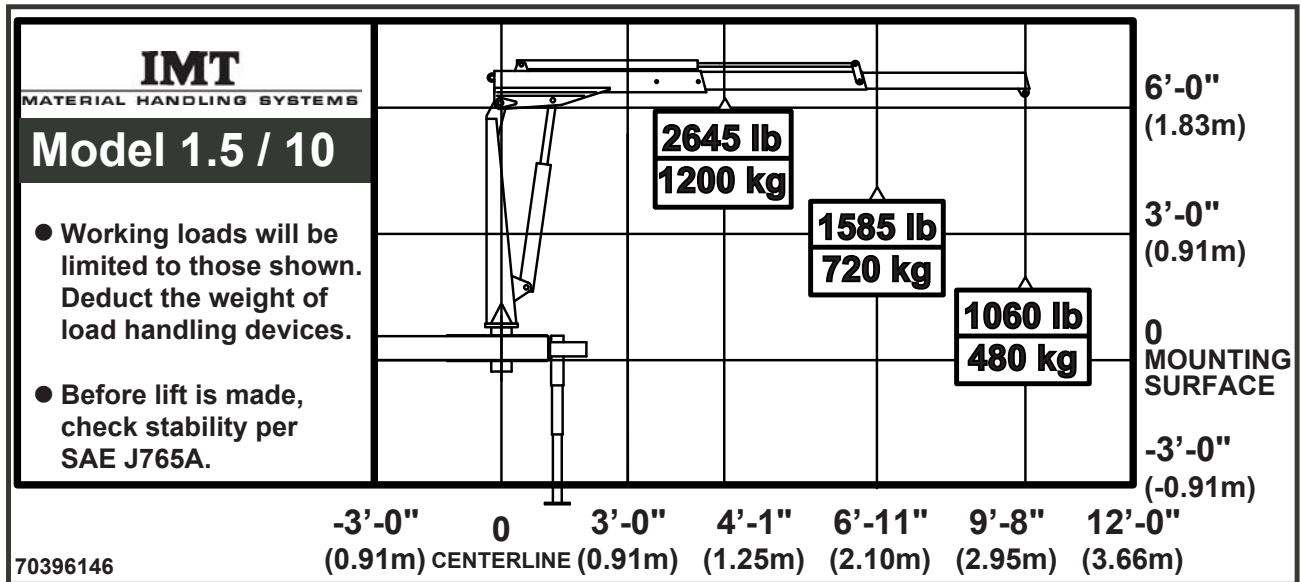

### 2.6.4 MODEL 2.0/15T CAPACITY CHART

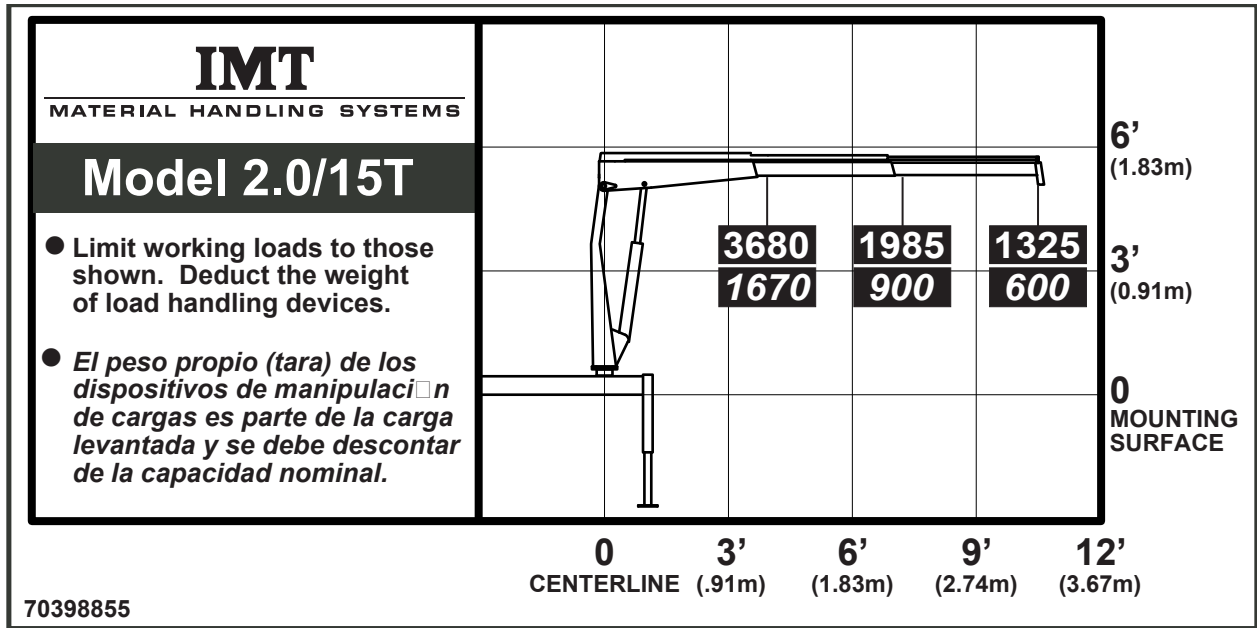

### 2.6.5 MODEL 2.6/19T CAPACITY CHART

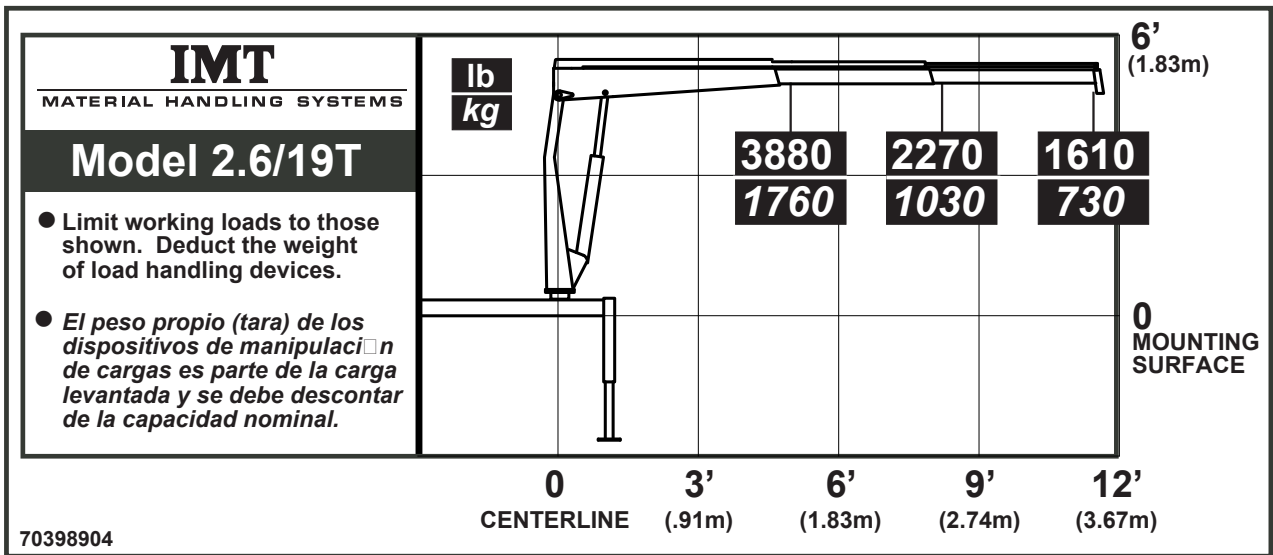

## 2.7 CRANE OPERATION

### 2.7.1 OPERATION - MODEL 0.5/4

Crane model 0.5/4 is operated using pumps and cranks. The lifting and lowering functions of the crane are operated using a hand pump with a needle valve, and the crane slew is operated by turning a crank. An optional power unit is available instead of the hand pump for lifting, if ordered with the crane.

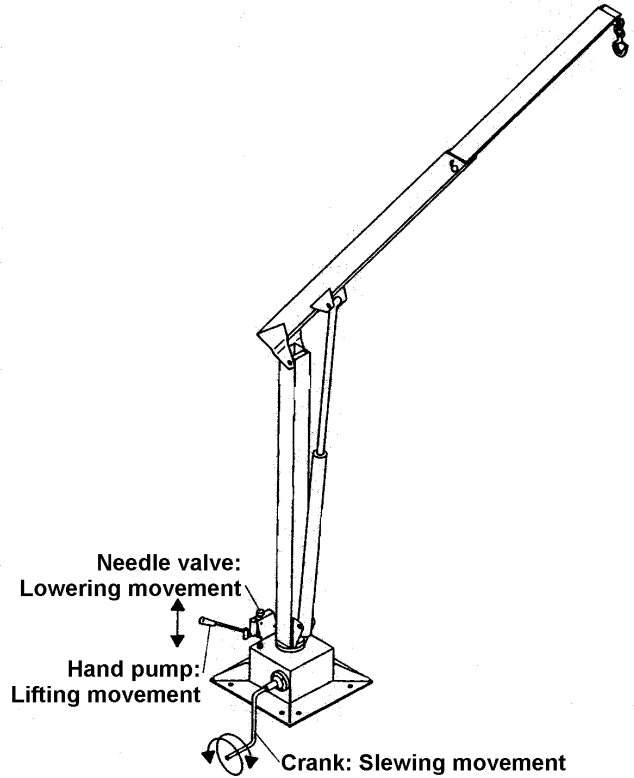

### 2.7.2 OPERATION - MODELS 1.5/10, 2.0/15T & 2.6/19T

These crane models are operated using control valves. Move the control valves gently, especially when working with heavy loads. The working speed of the crane is controlled using the valves. Jerky control valve operation causes the load to swing and move uncontrollably and put unnecessary strain on the crane.

**NOTE**

ALWAYS OPERATE CONTROL LEVERS GENTLY AND STEADILY.

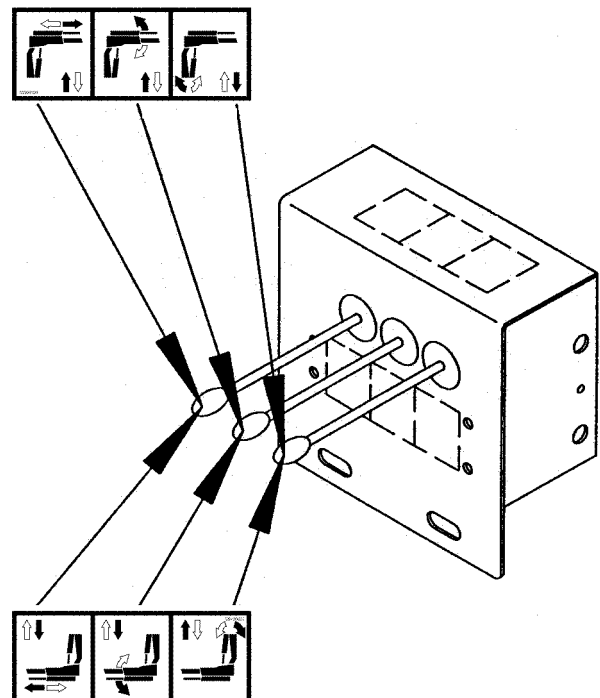

## 4.0 HYDRAULIC SAFETY SYSTEM

NOTE: Model 0.5/4 has manual extensions and controls, so this section does not apply to that model.

### 4.1 MODEL 1.5/10, 2.0/15T, 2.6/19T HYDRAULIC SAFETY SYSTEM

#### 1) Control Valve

Main relief valve

- Safeguard in case of overload.

#### 2) Rotation/Slewing Cylinder

Double port-relief valve

- Safeguard in case of overload.

#### 3) Lower Boom Cylinder

Single-acting load-holding valve

- Safeguard in case of hose failure/ overload
- Keeps the boom in position by relieving pressure on pipes and hoses

#### 4) Stabilizer Cylinder

Piloted check valve

- Safeguard in case of hose failure / overload

#### 5) Extension Cylinder

Double-acting, load-holding valve

- Safeguard in case of hose failure / overload
- Keeps the boom in position by relieving pressure on pipes and hoses

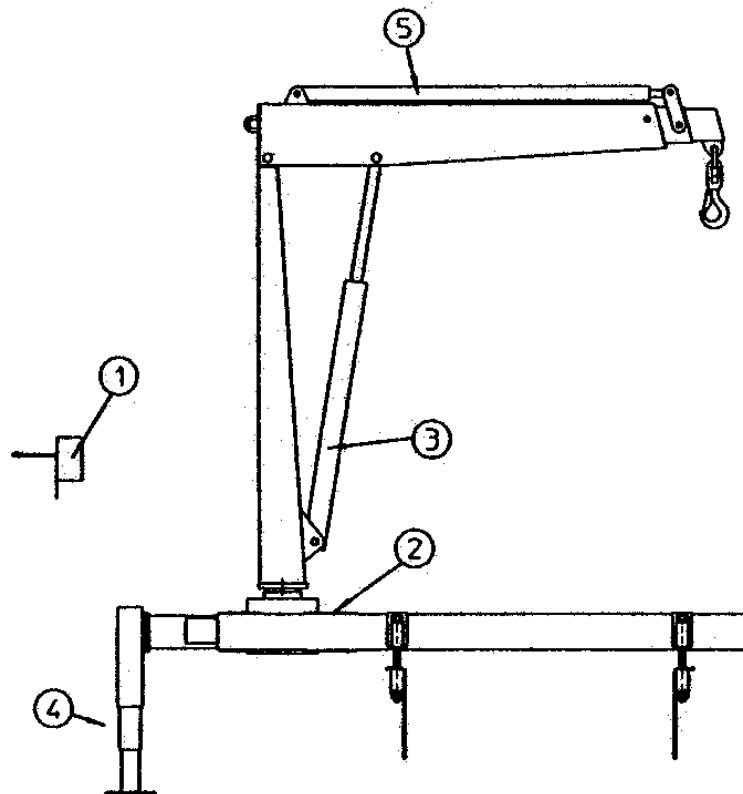

**4.3 MODEL 1.5/10 ELECTRO-HYDRAULIC DIAGRAM**

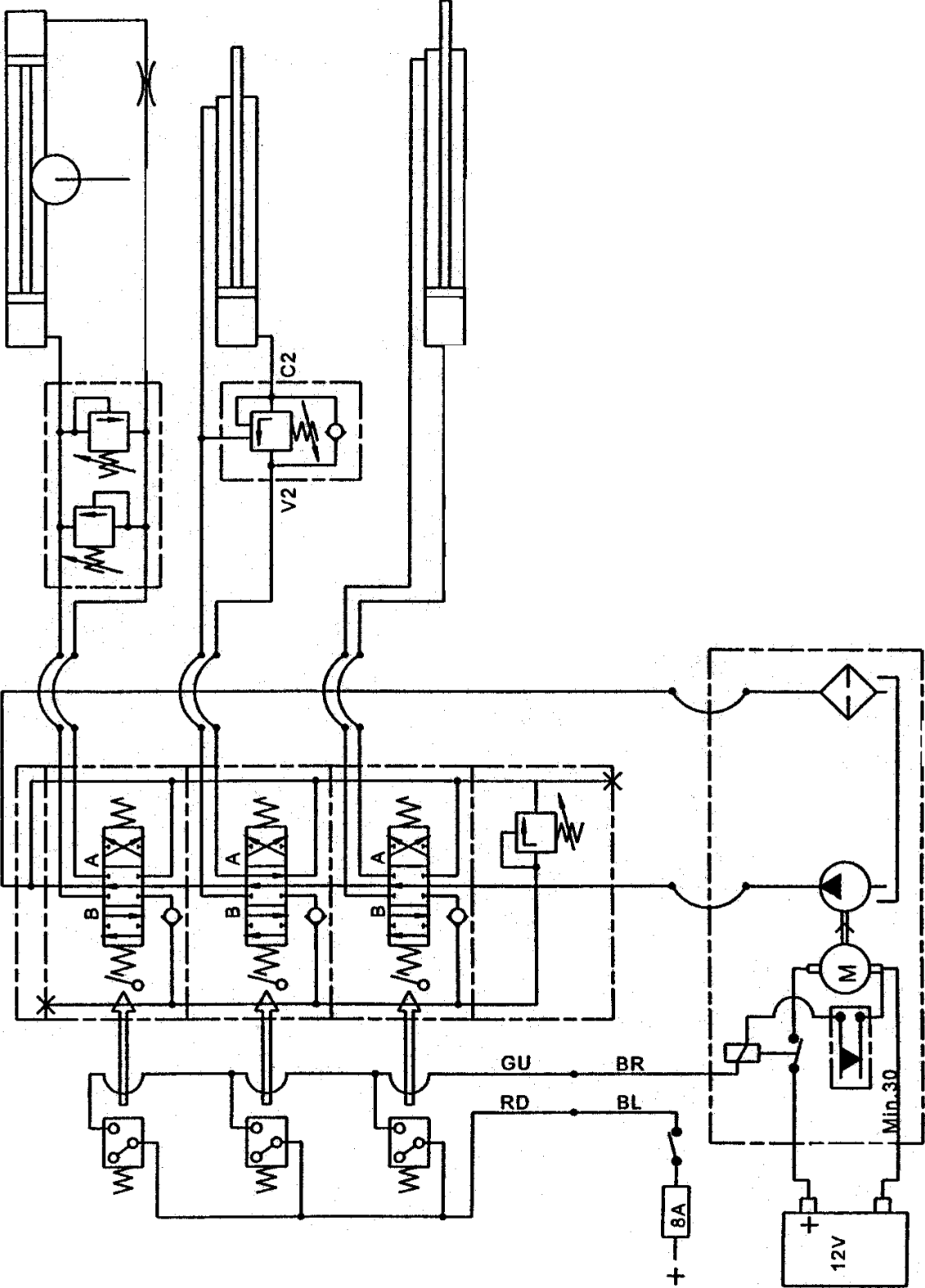

**4.3.2 MODEL 1.5/10 HYDRAULIC DIAGRAM**

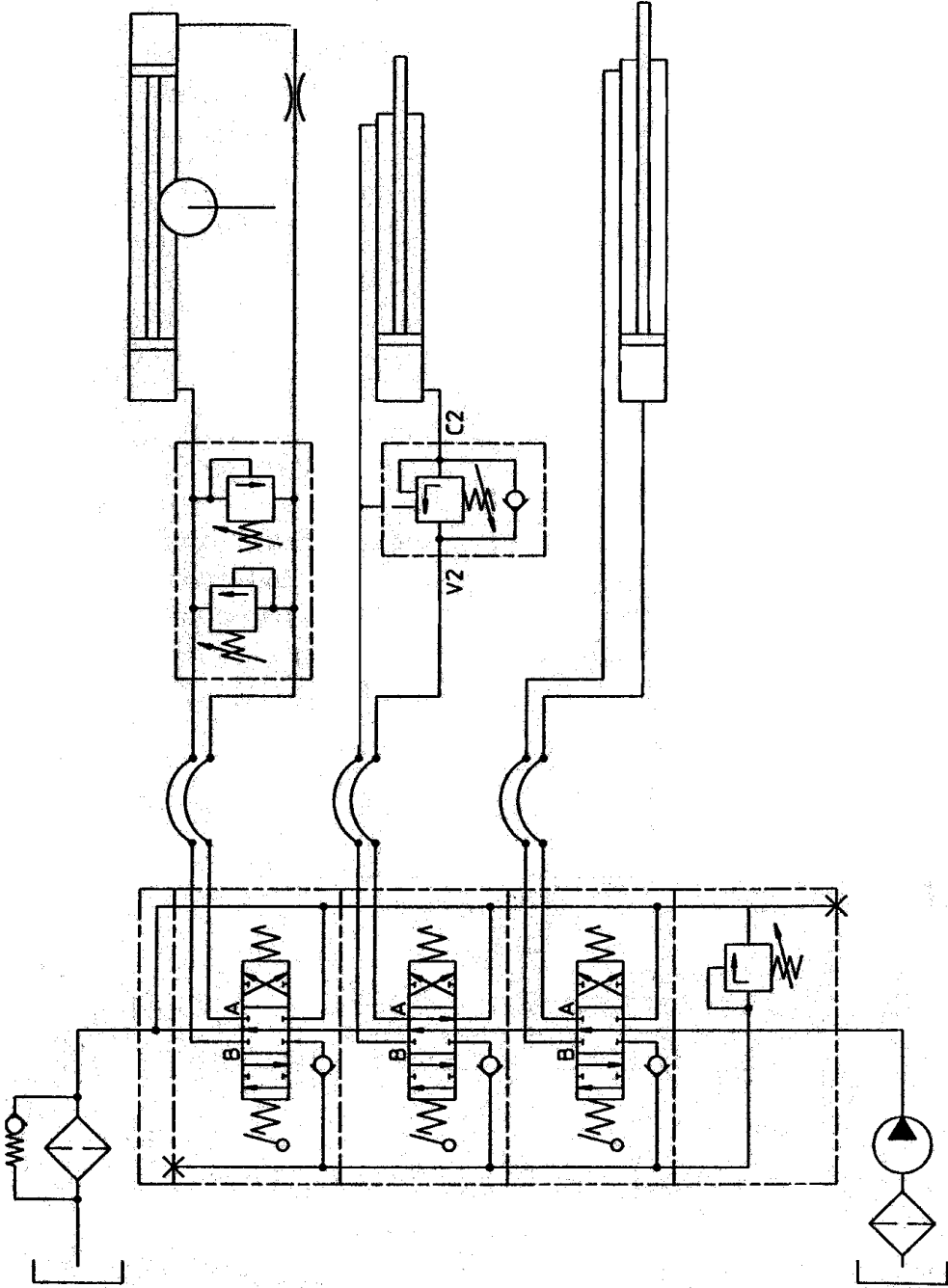

### 4.3.3 MODEL 2.0/15T ELECTRO-HYDRAULIC DIAGRAM

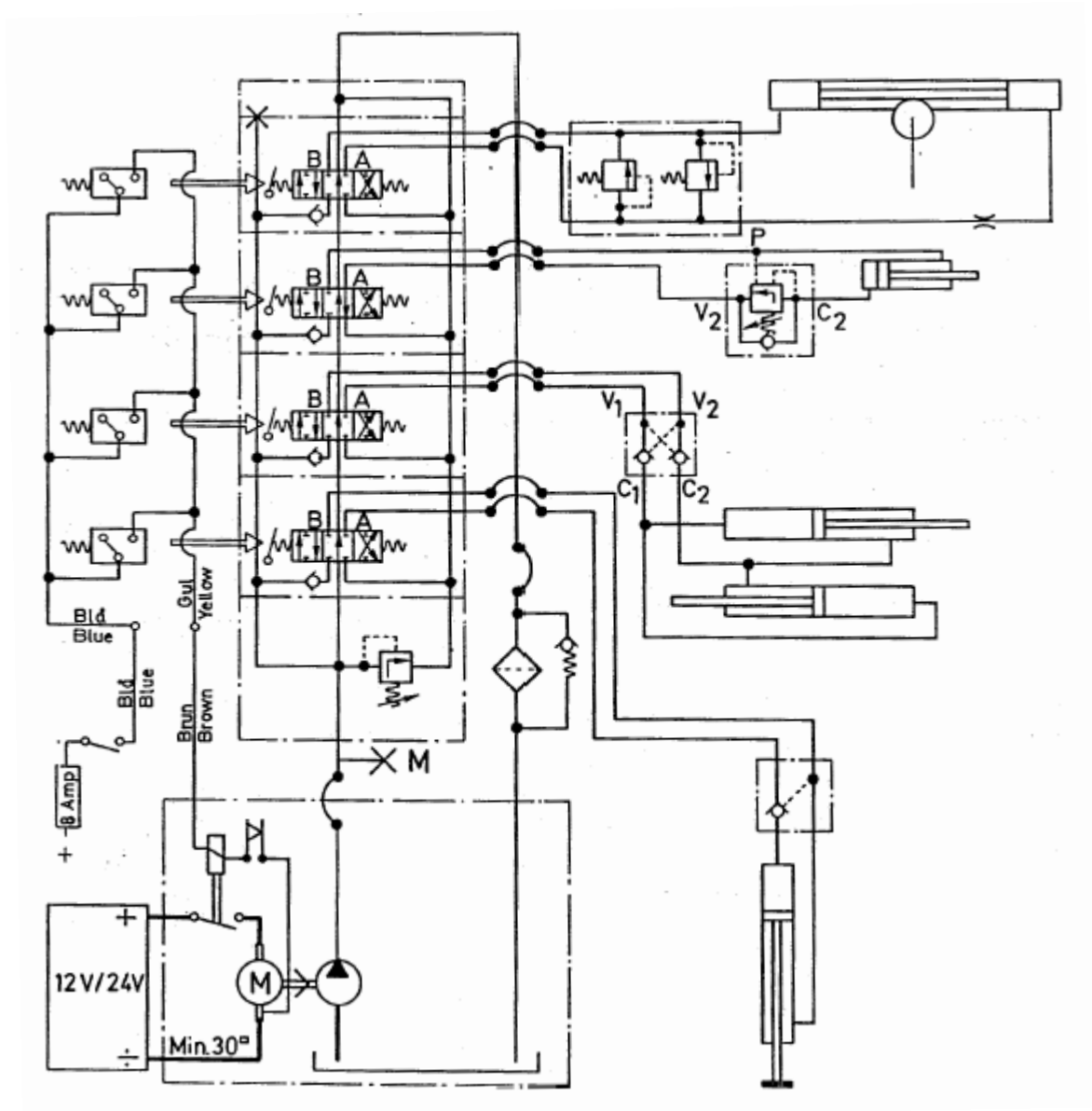



### 4.3.4 MODEL 2.0/15T HYDRAULIC DIAGRAM

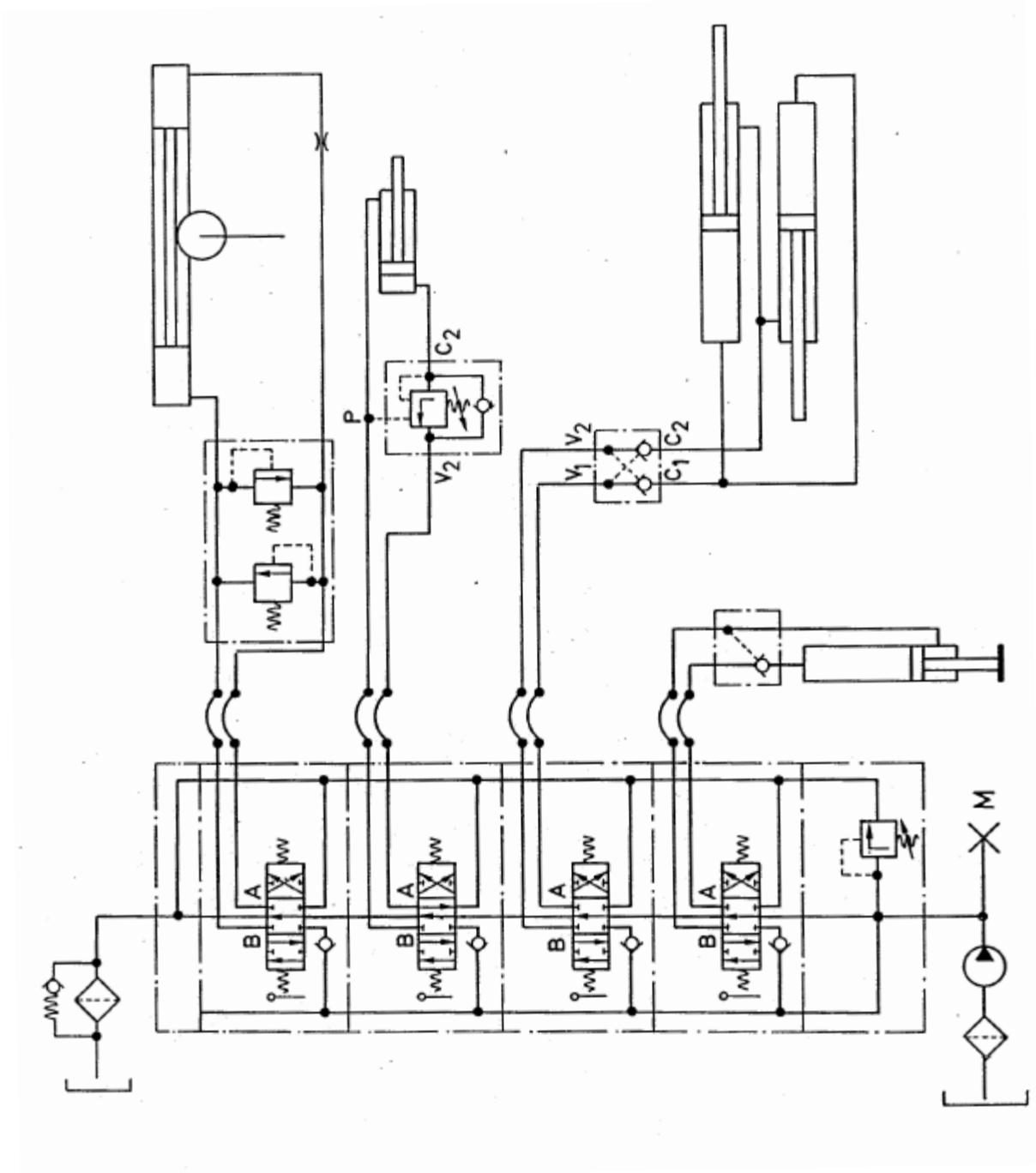

### 4.3.5 MODEL 2.6/19T ELECTRO-HYDRAULIC DIAGRAM

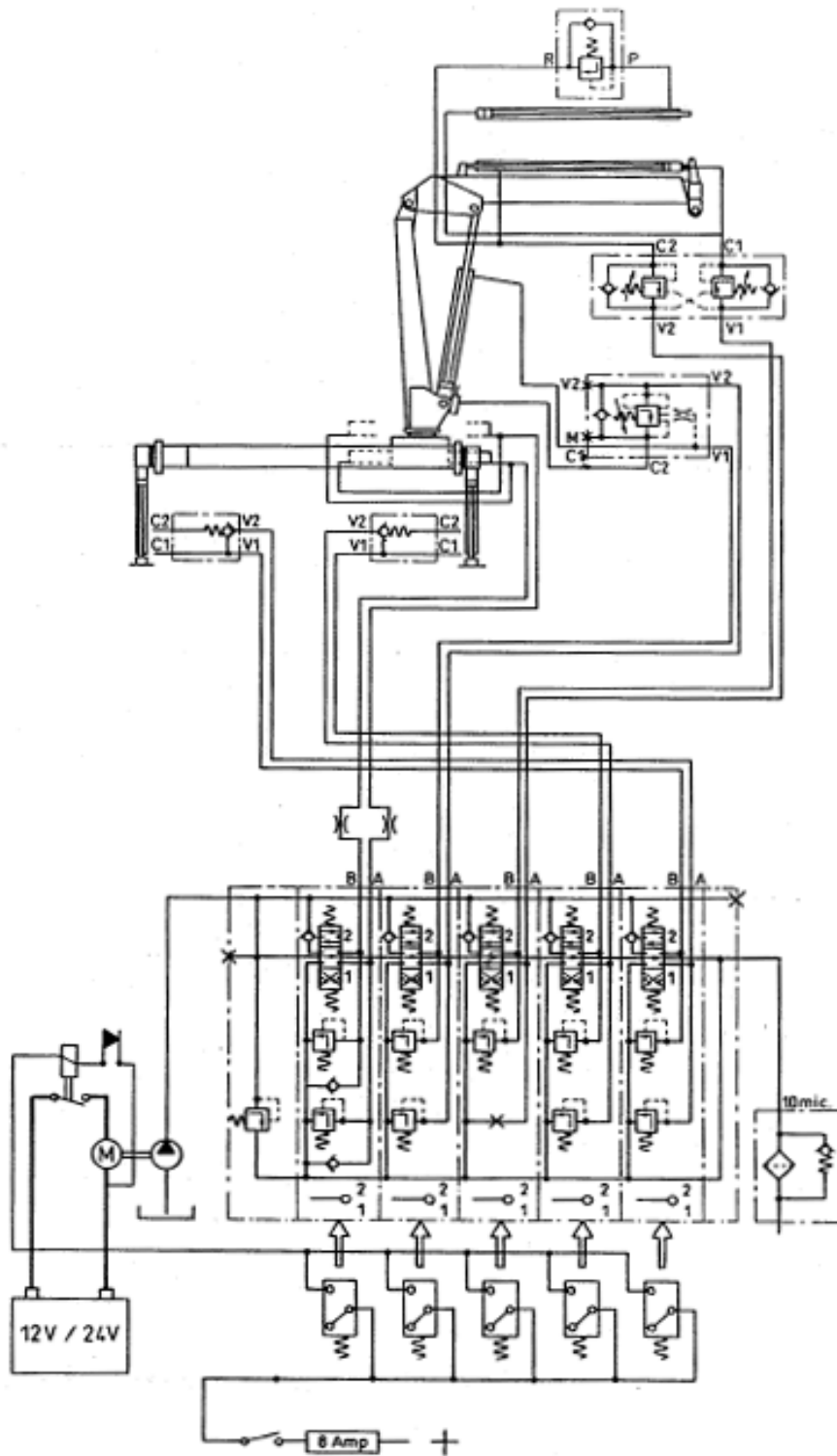

### 4.3.6 MODEL 2.6/19T HYDRAULIC DIAGRAM

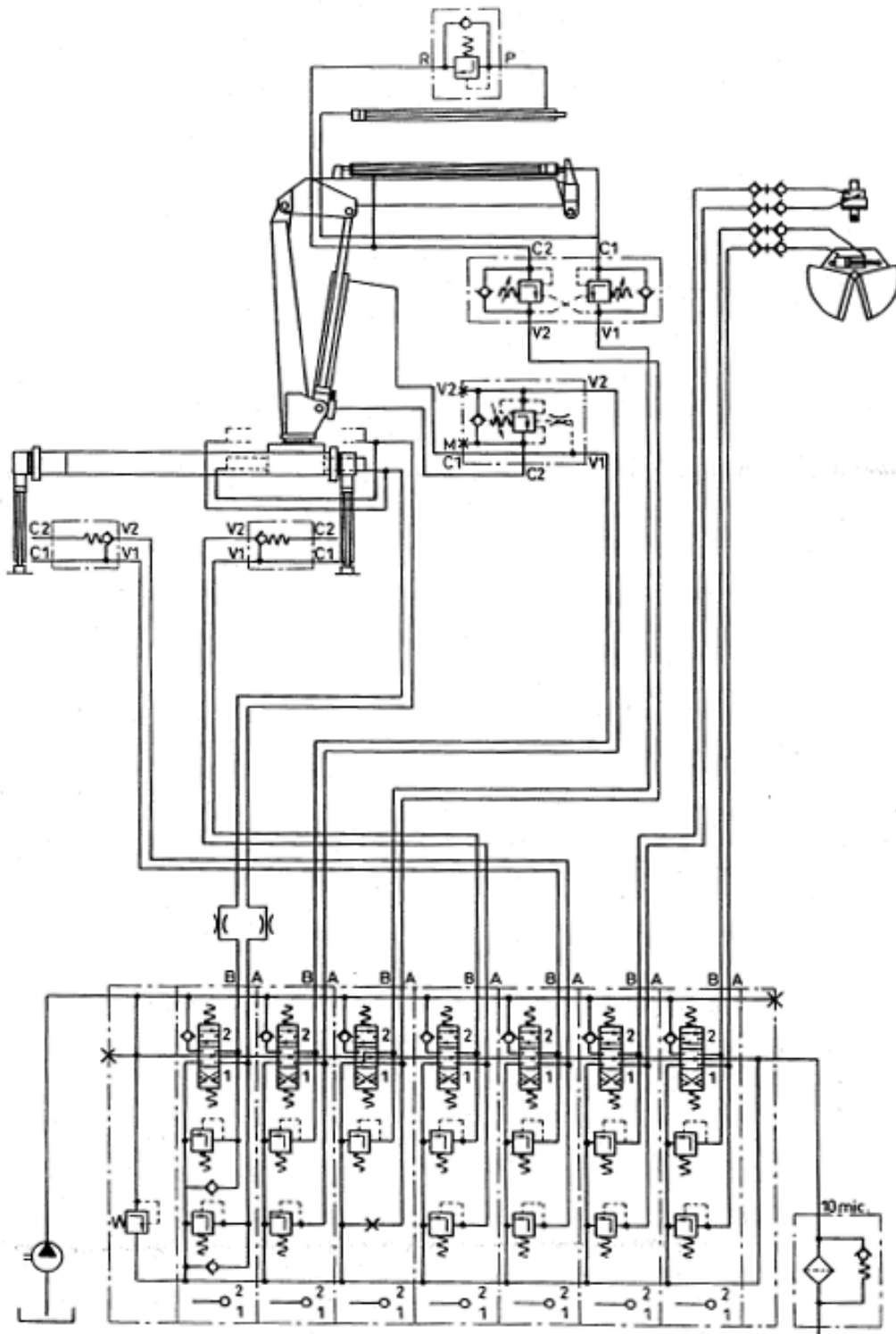

## 5.0 MAINTENANCE

### 5.1 MODEL 0.5/4 - DAILY MAINTENANCE POINTS

● Check pins, splits, etc.

■ Tighten bolts if necessary.

▲ Lubricate with oil can.

- Replenish the tank (base) if needed.
- Check hoses for damage and leaks.

Fill  
with  
oil.

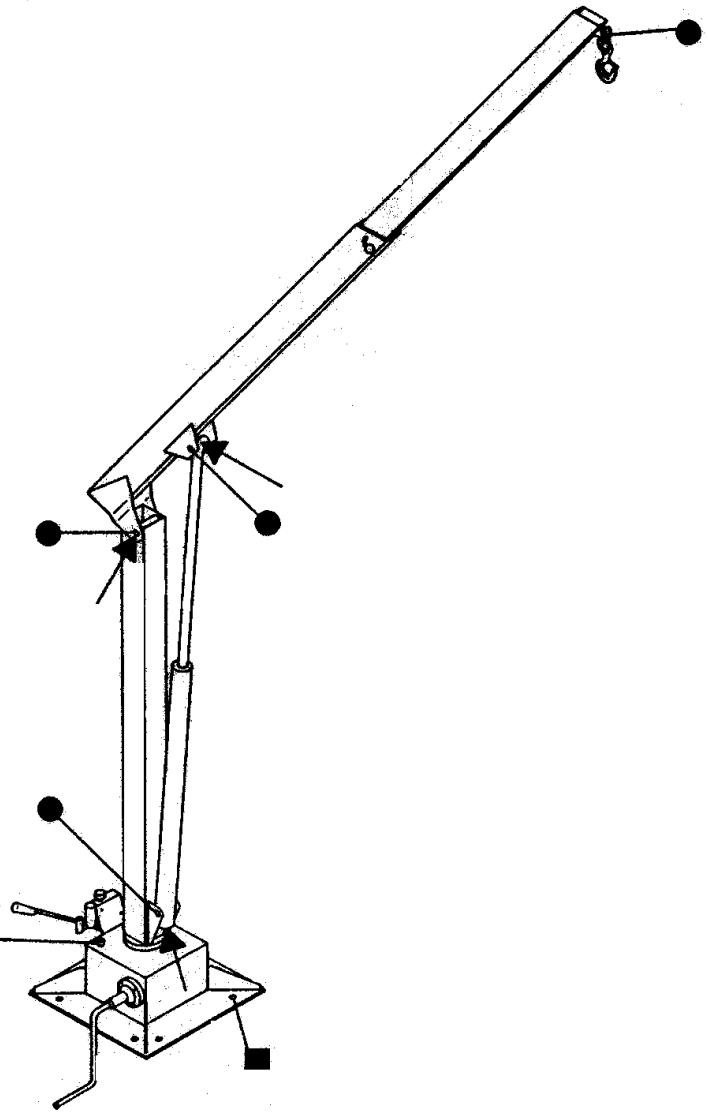

### 5.2 MODEL 1.5/10, 2.0/15T, 2.6/19T - DAILY MAINTENANCE POINTS

- Check the oil level in the base.
- Periodically check hoses and pipes for damage and leaks.

● Check pins, splits, etc.

■ Tighten bolts if necessary.

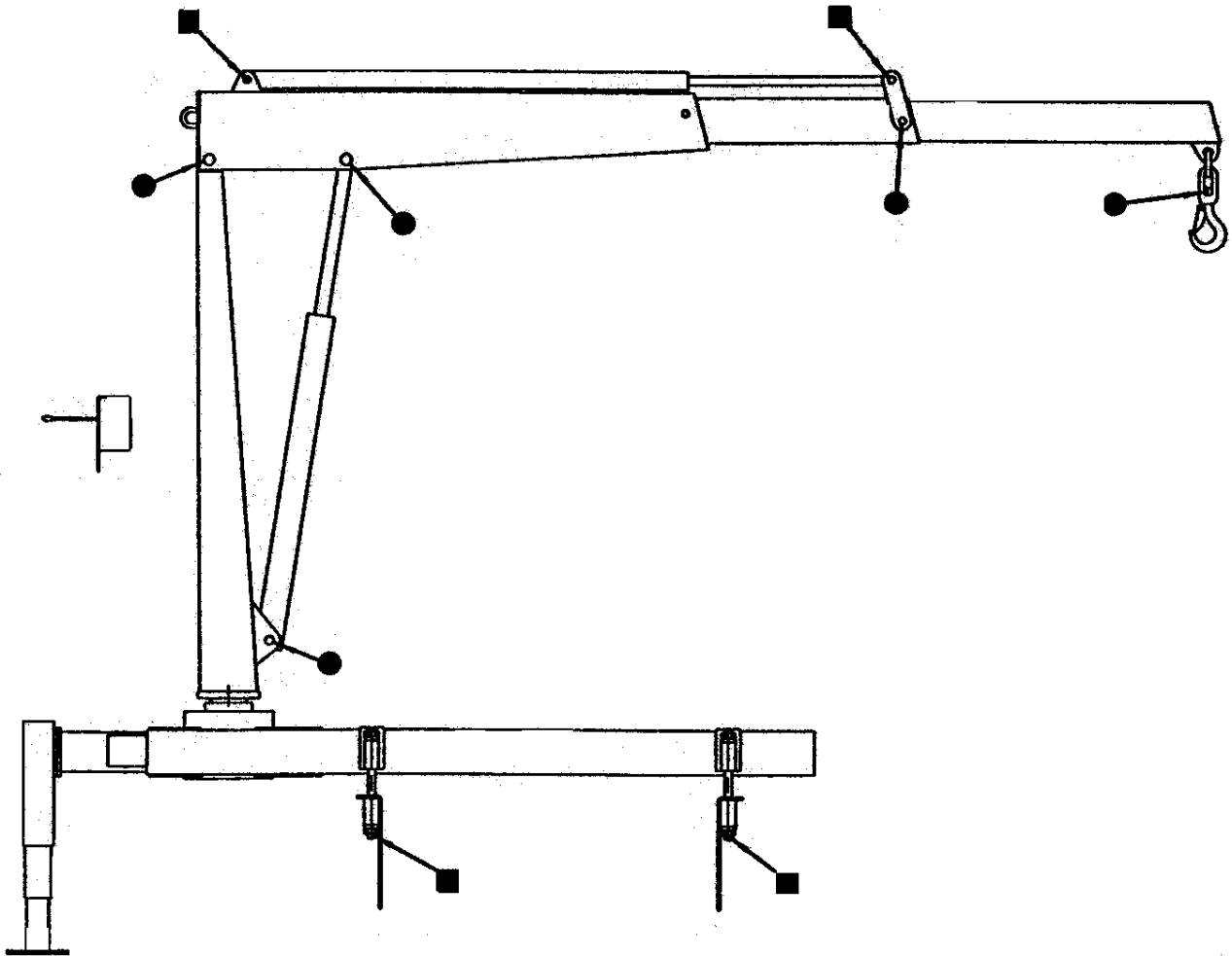



### 6.0 LUBRICATION & OIL CHANGE

The crane should be lubricated thoroughly at the same intervals as the truck. However, in case of intensive use, it should be lubricated weekly. If the crane is used continuously, it should be lubricated daily.

**NOTE:**

Check the oil level in the base periodically.

### 6.1 MODEL 1.5/10, 2.0/15T, 2.6/19T GREASE ZERK LOCATIONS

KEY - GREASE ZERK CHARTS	
●	Fill with oil at these locations.
▲	Grease zerk locations.
	Apply grease with a spatula.
	Apply grease with a brush.

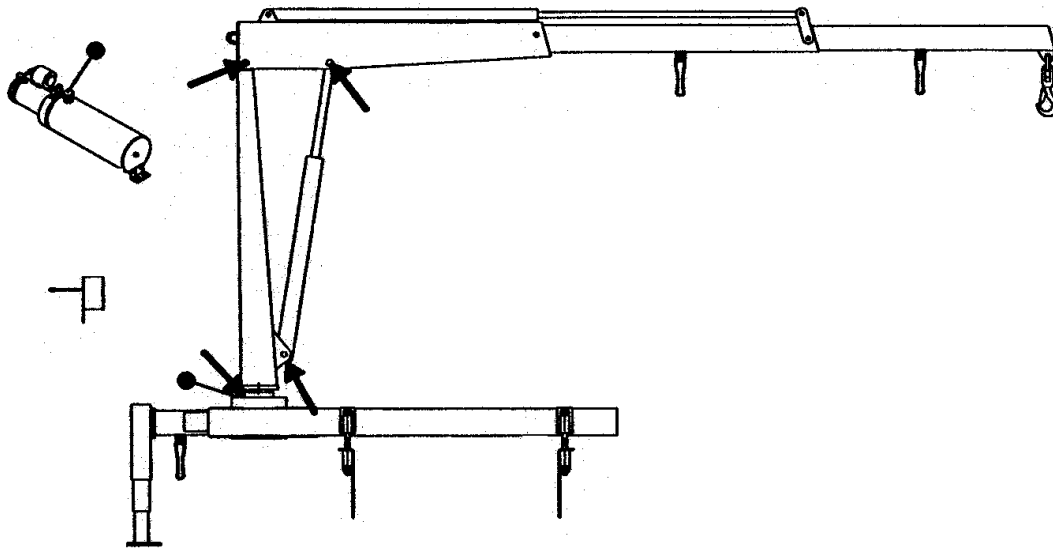

**NOTES:**

- Change oil and oil filter on an annual basis.
- Keep water and impurities from the oil tank.
- If necessary, refill the oil tank after bleeding air from the system.
- Do not mix different brands of oil.

## 6.3 CHANGING THE OIL AND OIL FILTER

### 6.3.1 MODEL 1.5/10, 2.0/15T, 2.6/19T - CHANGING THE OIL & OIL FILTER BY THE ELECTRIC POWER PACK

1. Fold the crane completely.
2. Remove the air filter (1), and empty the oil tank.
3. Dismantle the nut (3) in the end plate of the oil tank, remove the tank, and change the oil filter (2) if necessary.
4. Mount the tank and fill it with oil.

NOTE: Fill the tank with 2.11 gallons (8 l) of oil, even if the base is not used as a tank.

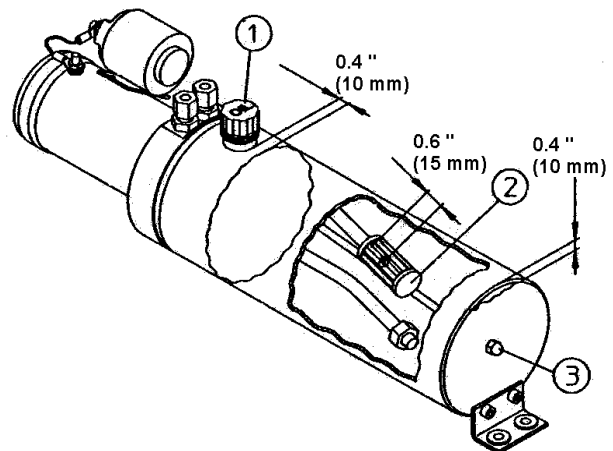

### 6.3.2 MODEL 1.5/10, 2.0/15T, 2.6/19T - CHANGING THE OIL & OIL FILTER BY PTO-HYDRAULIC

1. Remove the air filter (1) and the drain plug. Empty the oil tank.
2. Change the oil filter (2).
3. Mount the drain plug. Fill the tank with oil.
4. Mount the air filter (1).

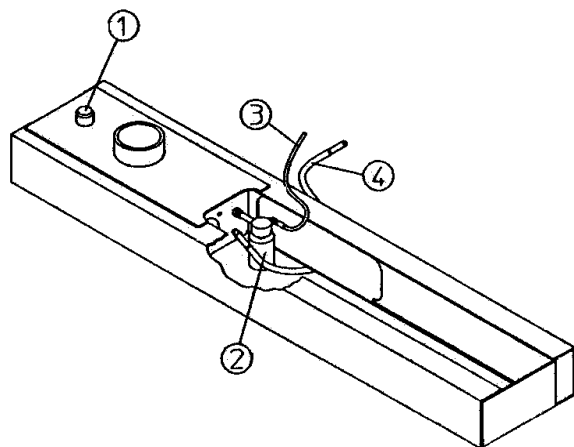

### 6.3.4 HYDRAULIC OIL & GREASE SPECIFICATIONS

Choose hydraulic oils and greases using the tables below as guides. If the loader will be working below 32° F (0° C), select an oil designed for low temperatures, which has a higher viscosity index. Oil types not specified on the charts may be used if they correspond to the quality and specifications indicated.

In the winter, 1% isopropyl alcohol may be added to the oil to avoid condensed water problems.

During extreme temperatures, -40° F / + 167 °F (-40° C / +75° C), select hydraulic oil such as Esso Univis J26 or another comparable brand.

Grease telescopic jibs with Esso ESL 454. Apply grease where the telescopic jibs contact the slide blocks.

APPLICATION POINT	LUBRICATION PRODUCT	APPLICATION MEANS	INTERVAL
Pinion and Drive Gear Rotation Brake Winch Brake Winch Sheave Turntable Bearing Cylinder Pins Boom Hinge Pins Boom Rollers	Shell Alvania 2EP OR Shell Retinax "A" OR Mobilith AW2 OR Equivalent	Hand Grease Gun OR Pneumatic Pressure Gun	Weekly
Rotation Worm Gear	Molub-Alloy 936 or Equiv.	Brush On	Weekly
PTO Transmission Winch Sump	Mobilube HD 80W90	Fill to Check Plug	Monthly

### HYDRAULIC OIL SPECIFICATIONS AND APPLICATION POINTS

AMBIENT TEMPERATURE RANGE	0 - 90°	BELOW 0°	ABOVE 90°
Minimum Pour Point, °F	-40°	-40°	-10°
Maximum Viscosity, SSU @ 0°F	5000	1500	---
Minimum Viscosity, SSU @ 100°F	140-195	80-90	200-335
Minimum Viscosity, SSU @ 210°F	48	39	49
Minimum Viscosity Index	139	139	95
ISO VG Grade	32	15	46
Mobil Oils (Reference)	DTE 13M	DTE 11M	DTE 25

### LUBRICANT SPECIFICATIONS



## 7.0 BLEEDING AIR FROM CYLINDERS

### 7.1 MODEL 1.5/10, 2.0/15T, 2.6/19T

If air has entered the hydraulic system, bleed the air from the cylinders by:

- 1) Fold the crane completely. Fill the oil tank with 2.11 gallons (8 l) of oil.
- 2) Follow the steps in the diagram below to bleed the air from the cylinders.
- 3) Refill the oil tank after bleeding the cylinders.

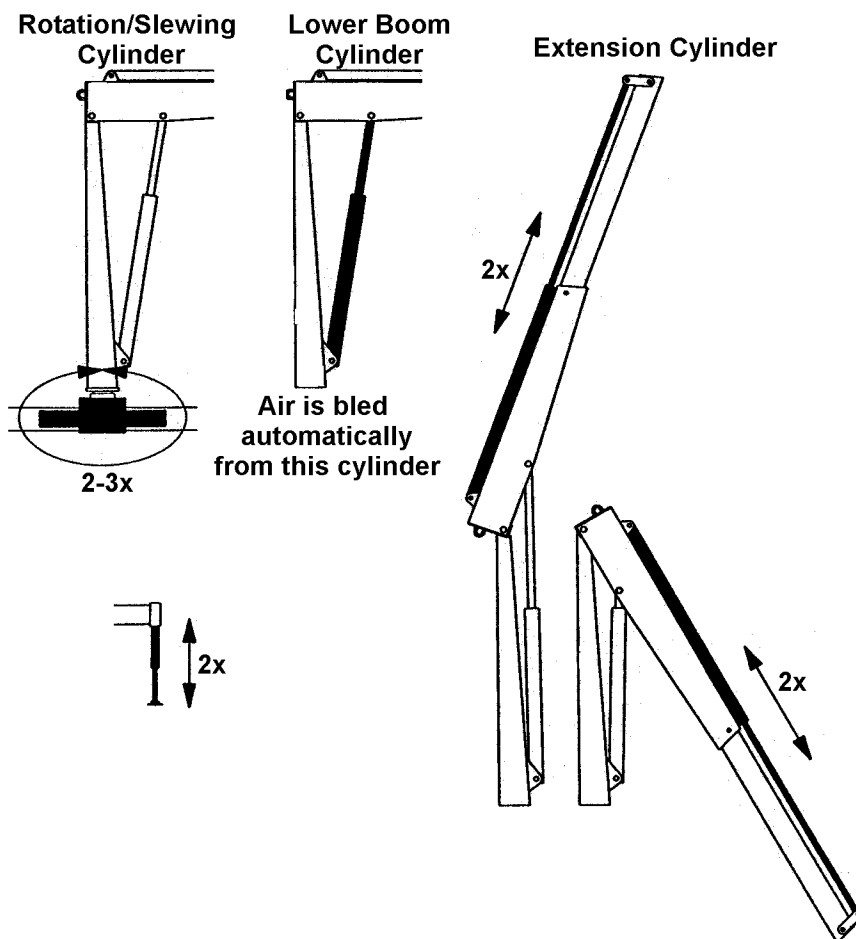

### 7.3 ACCESSORIES (MODELS 1.5/10, 2.0/15T, 2.6/19T ONLY)

#### MANUAL EXTENSIONS

An extra jib extension can be supplied for the loader. The manual extension is adapted especially for the particular type of loader. It should not be shortened or lengthened.

Use only factory original manual extensions.

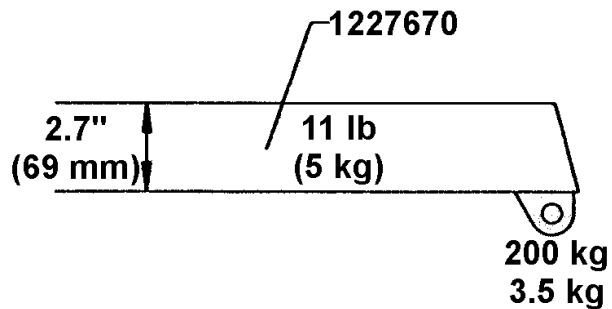

## 8.0 CHANGE OF SLEWING AREA

### 8.1 MODEL 1.5/10, 2.0/15T, 2.6/19T CHANGE OF SLEWING AREA

- 1) Position the crane so that the slew to both sides is exactly the same (neutral position).
- 2) Remove oil from the base using the drain plug (5).
- 3) Remove the slewing cylinder (1).
- 4) Pull out the slide block (4) using the M8 threaded hole.
- 5) Pull out the rack (3).
- 6) Manually turn the loader column to the required "C" (Figure 2).
- 7) Place the rack (3) in the slewing house. The distance between the outer part of the rack (3) and the end plate must be approximately  $2.8'' \pm .3''$  (71.5 mm  $\pm$  8 mm), depending on the mutual mesh of the teeth.
- 8) Place the slide block (4) behind the rack (3). Remount the slewing cylinder (1).
- 9) Lubricate the bolts (2) with Locktite Normal or Locktite No. 242. Screw the bolts back in.
- 10) Replace the drain plug (5). Replace oil if needed.

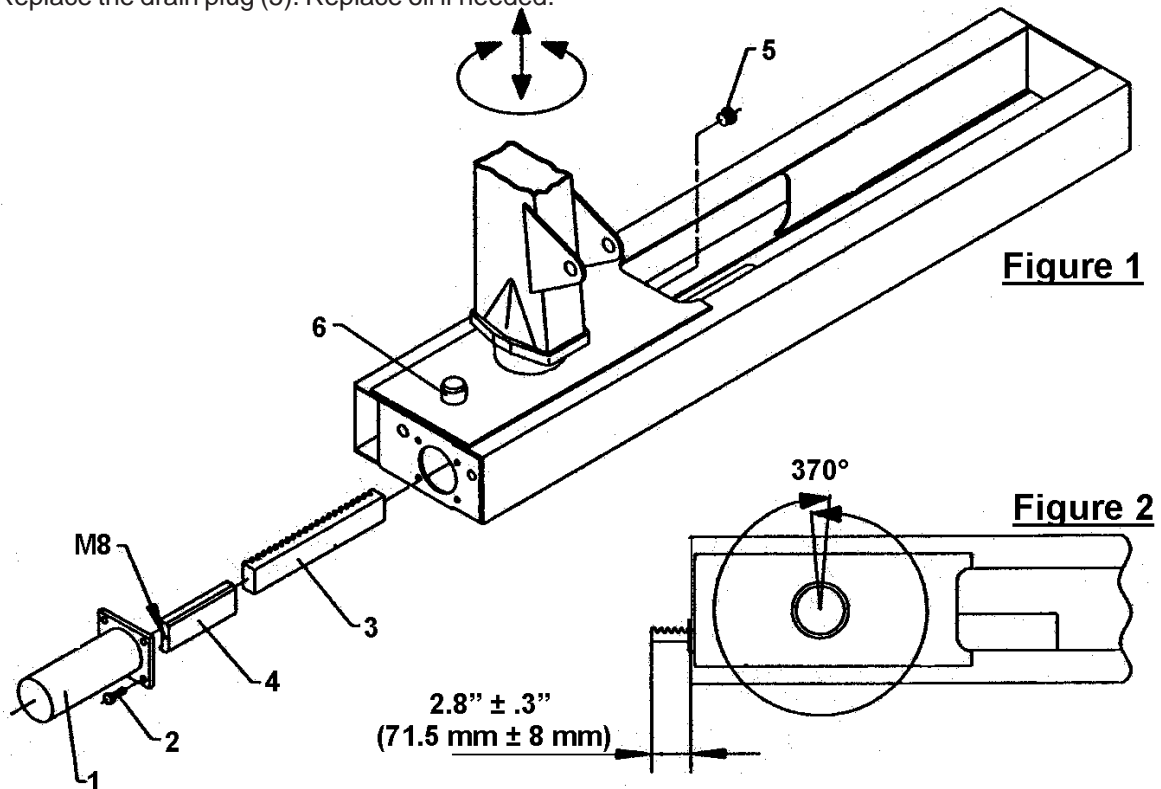

9.0 TECHNICAL DATA

9.1A MODEL 0.5/4 DIMENSIONAL DRAWINGS

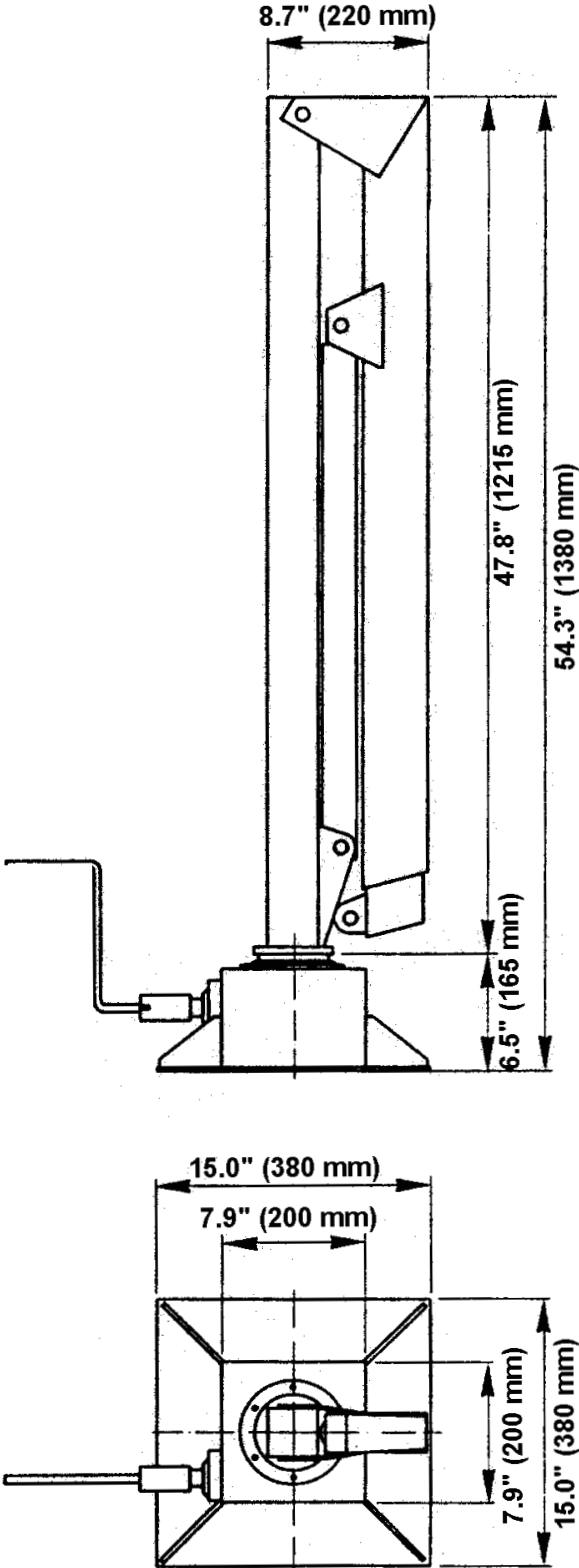

**9.1B MODEL 0.5/4 TECHNICAL DATA**

LOAD MOMENT	0.5 TM
LIFTING CAPACITY AT:	4'-11" (1.5 m)    948 lb (430 kg) 6'- 7" (2.0 m)    551lb (250 kg)
MANUAL EXTENSIONS	1
MAX. LIFTING HEIGHT ABOVE BASE	122" (3100 mm)
MAX. LOWERING BELOW BASE	35.4" (900 mm)
HEIGHT ABOVE PLATFORM IN PARKED POSITION	54.3" (1380 mm)
POWER SOURCE	HYDRAULIC HAND PUMP (OPTIONAL ELECTRIC POWER PACK FOR LIFT)
SLEWING SYSTEM	WORM GEAR IN OIL BATH
SLEWING ANGLE	> 360°
WEIGHT	137 lb (62 kg)

### 9.2A MODEL 1.5/10 T1 (T2) DIMENSIONAL DRAWINGS

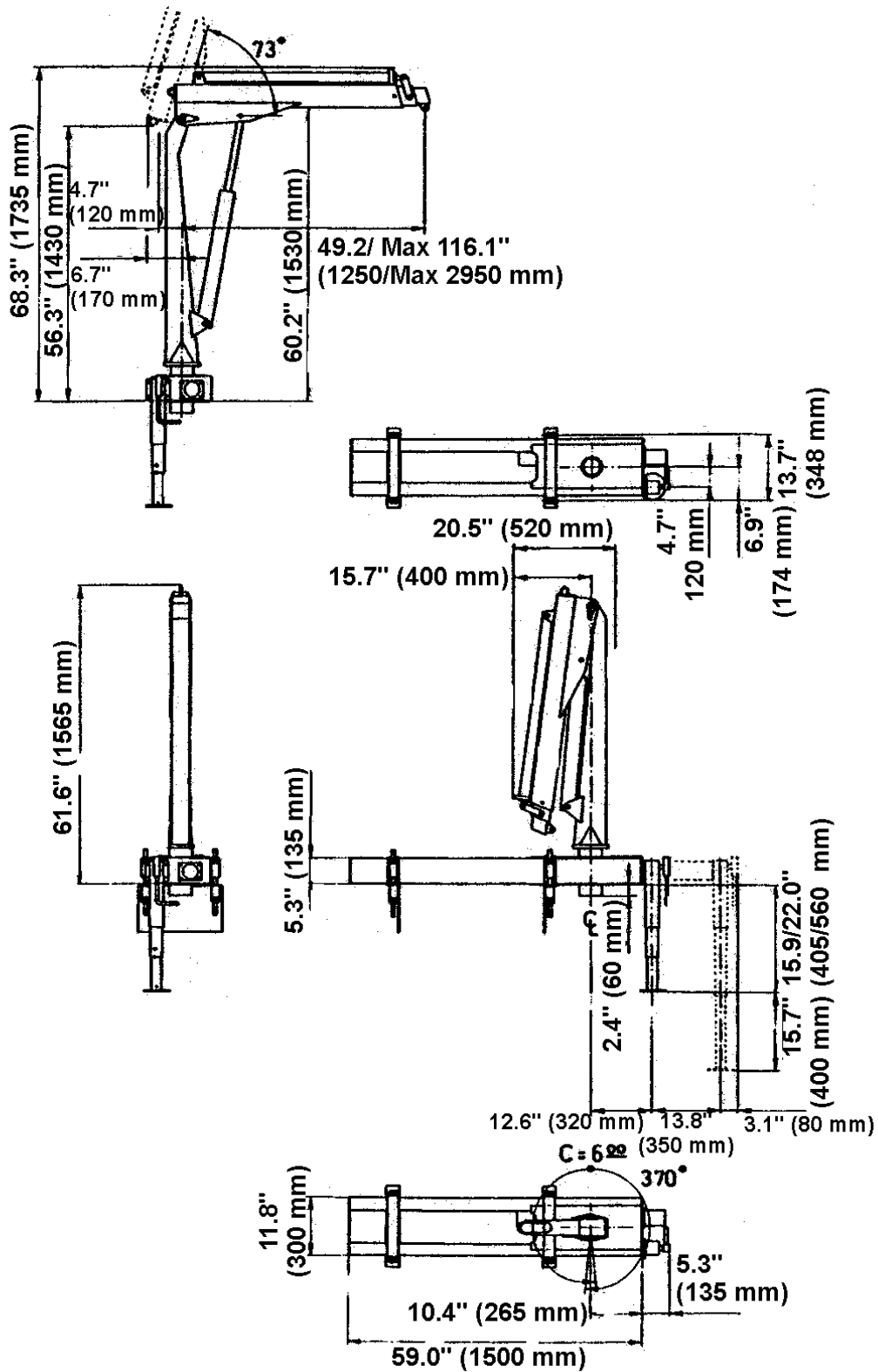

**9.2B MODEL 1.5/10 T1 M (T2 M)  
DIMENSIONAL DRAWINGS**

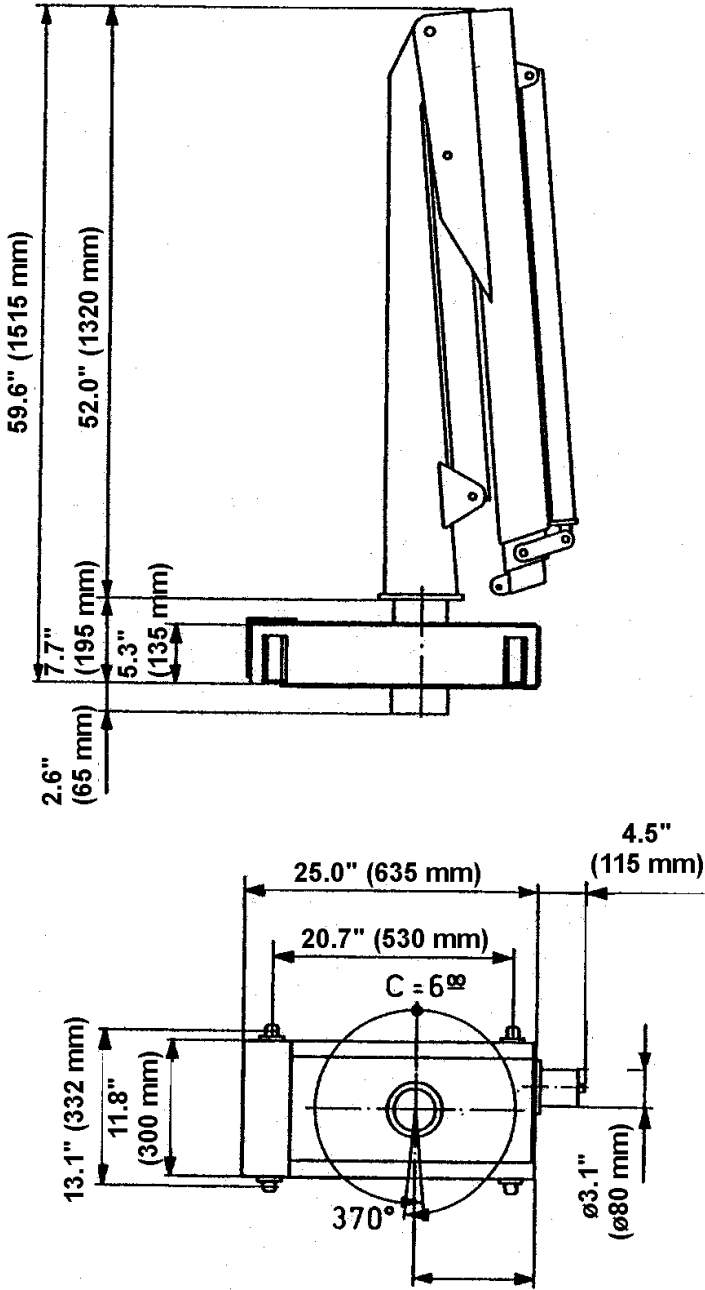

**9.2C MODEL 1.5/10 TECHNICAL DATA**

	<b>T1</b>	<b>T2</b>	<b>T1 M</b>	<b>T2 M</b>
LOAD MOMENT	1.5 tm	1.5 tm	1.5 tm	1.5 tm
HYDRAULIC REACH	6'-11" (2.1 m)	9'-8" (2.95 m)	6'-11" (2.1 m)	9'-8" (2.95 m)
SLEWING TORQUE	1013 ft-lb (140 kgm)	1013 ft-lb (140 kgm)	1013 ft-lb (140 kgm)	1013 ft-lb (140 kgm)
HEIGHT ABOVE CHASSIS WHEN FOLDED	61.6" (1565 mm)	61.6" (1565 mm)	59.6" (1515 mm)	59.6" (1515 mm)
WIDTH WHEN FOLDED	20.5" (520 mm)	20.5" (520 mm)	20.5" (520 mm)	20.5" (520 mm)
STABILIZER SPREAD, EXTENSION	13.8" (350 mm)	13.8" (350 mm)	--	--
WEIGHT, LOADER INCL. STABILIZER LEG & POWER PACK	407.9 lb (185 kg)	440.9 lb (200 kg)	--	--
WEIGHT, LOADER EXCL. STABILIZER LEG & POWER PACK	--	--	352.7 lb (160 kg)	385.8 lb (175 kg)
OIL IN BASE	17.6 lb (8 kg)	17.6 lb (8 kg)	17.6 lb (8 kg)	17.6 lb (8 kg)
OIL IN CYLINDERS & HOSES	8.8 lb (4 kg)	8.8 lb (4 kg)	8.8 lb (4 kg)	8.8 lb (4 kg)

**9.2D POWER CONSUMPTION / PUMP PERFORMANCE**

	ALL MODELS
WORKING PRESSURE	2248 psi (15.5 MPa)
PUMP PERFORMANCE	1.06-2.11 gpm (4 - 8 l/min)
MAX. POWER CONSUMPTION	
12 volt:	155 Amp
24 volt:	80 Amp
BATTERY CAPACITY	
12 volt:	120 Ah
24 volt:	80 Ah
OIL CAPACITY IN BASE	2.11 gal (8 l)



9.4A: DIMENSIONAL DRAWING, 2.0/15T

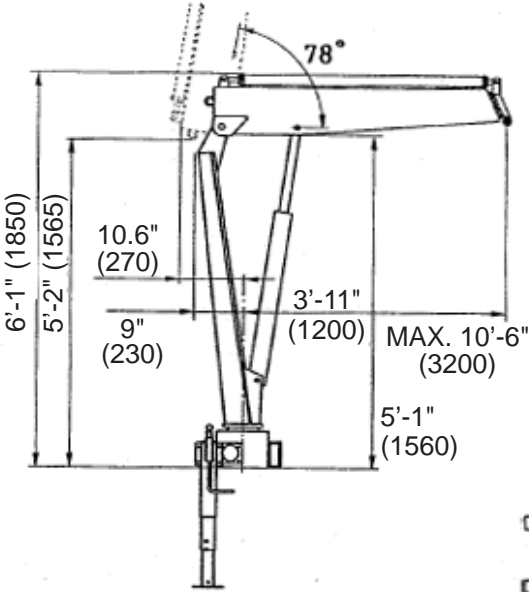

Dimensions shown in feet-inches (mm).

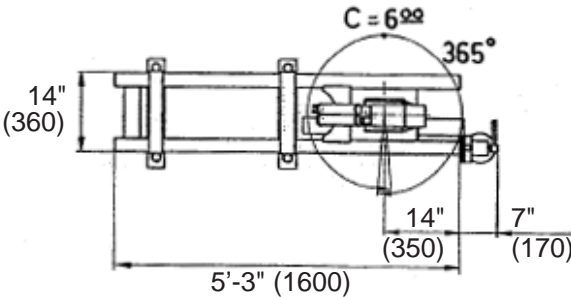
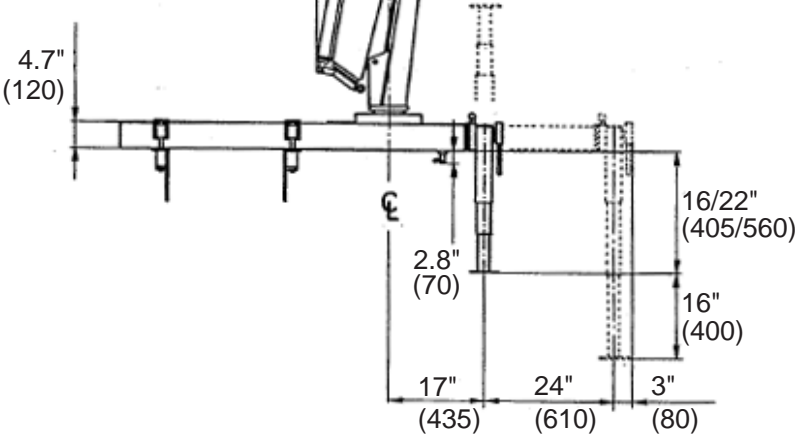
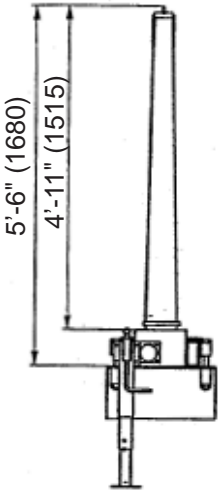
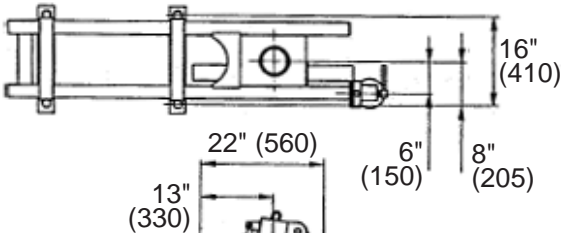

### 9.4B: DIMENSIONAL DRAWING, 2.0/15T STATIONARY MOUNT

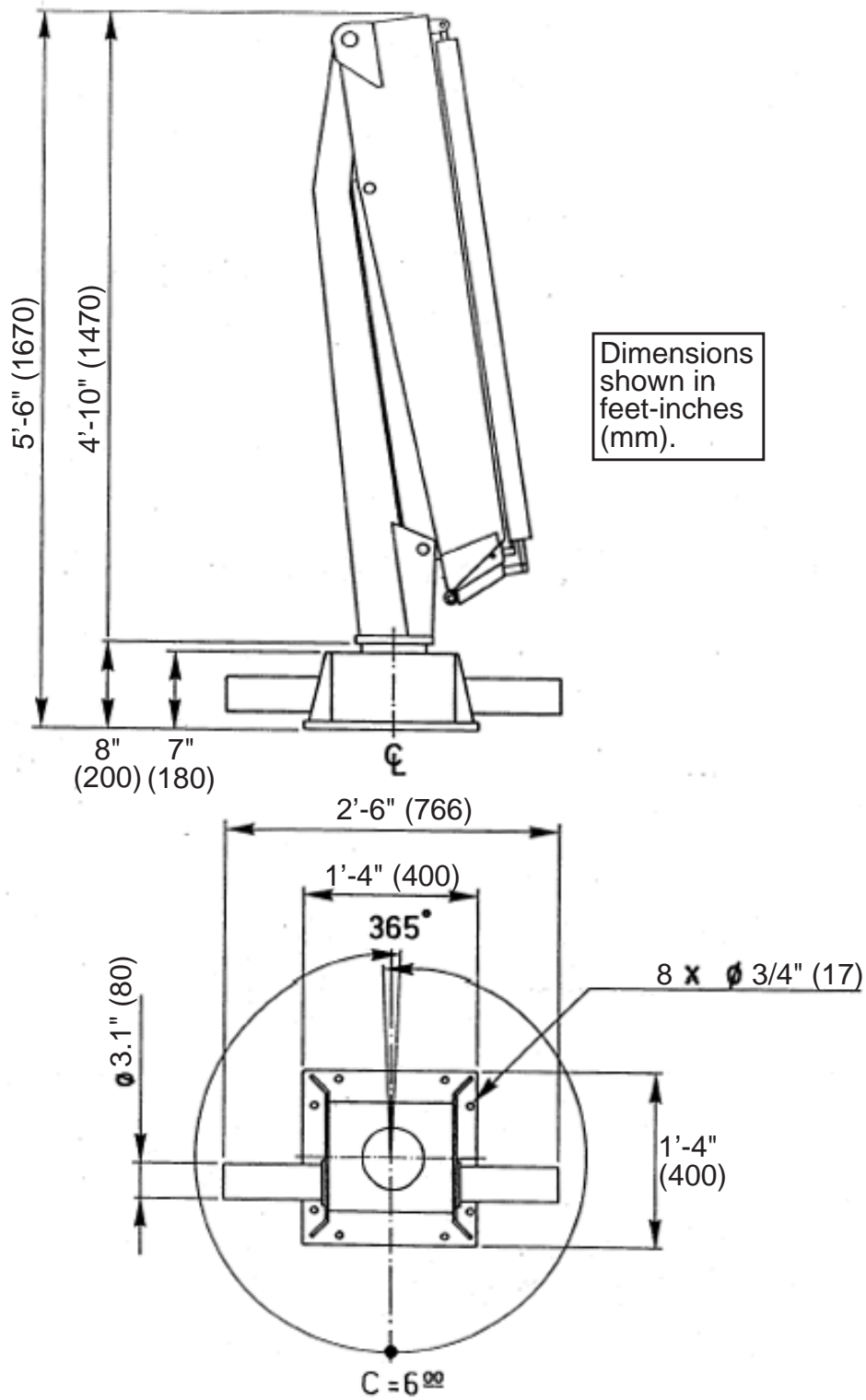

**9.4C: 2.0/15T TECHNICAL DATA**

<b>2.0/15T</b>	<b>2-HYDRAULIC</b>	<b>2-HYDRAULIC STATIONARY-MOUNT</b>
Crane Rating*	14,465 ft-lb (2.0 tm)	14,465 ft-lb (2.0 tm)
Maximum Horizontal Reach	10' 6" (3.2 m)	10' 6" (3.2 m)
Maximum Vertical Reach	15' 9" (4.8 m)	15' 9" (4.8 m)
Maximum Capacity	3680 lb (1670 kg)	3680 lb (1670 kg)
Max Cap @ Max Reach	1325 lb (600 kg)	1325 lb (600 kg)
Crane Weight, incl. stabilizer and power pack	530 lb (240 kg)	
Crane Weight, excluding power pack		660 lb (300 kg)
Center of Gravity - Stored		
Vertical	16" (405 mm)	
Horizontal (C/L RotTo Bridge)	4" (100 mm)	
Stabilizer Pad Diameter	6" (160 mm)	6" (160 mm)
Crane Storage Height	5' 6" (1680 mm)	5' 6" (1670 mm)
Mounting Space	1' 10" (560 mm)	1' 10" (560 mm)
Rotational Torque	1375 ft lb (190 kg-m)	1375 ft lb (190 kg-m)
Rotation	365 degrees	365 degrees
Optimum Pump Performance	1.6 - 2.1 gpm (6-8 L/min)	1.6 - 2.1 gpm (6-8 L/min)
System Pressure	2610 psi (180 bar)	2610 psi (180 bar)
Oil Capacity in Base	1.7 gal (6.5 L)	1.7 gal (6.5 L)
Stabilizers		
Extension	2'-0" (610 mm)	--
Weight	440 lb (200 kg)	--

**PRESSURE SETTINGS**

Use a pressure gauge when setting pressures. Check pressure with annual inspection and after all major repairs.

**WORKING PRESURE ON PORT-RELIEF VALVE**

Main relief valve	2610 psi (180 bar)	2610 psi (180 bar)
Rotation (slewing) system	1815 psi (125 bar)	1815 psi (125 bar)

**OPENING PRESURE ON LOAD-HOLDING VALVES**

Boom cylinder	2755 psi (190 bar)	2755 psi (190 bar)
---------------	--------------------	--------------------

**PRESURE SETTINGS**

90% load	2320 psi (160 bar)	2320 psi (160 bar)
100% load	2610 psi (180 bar)	2610 psi (180 bar)

**PRESSURE SETTINGS FOR LOAD-MOMENT LIMITATION**

Set the working pressure of the load-moment limitation to 145 psi (10 bar) less than the opening pressure of the load-holding valves of the boom cylinder. Thus, the setting is 2610 psi (180 bar).

\* Crane rating (ft-lb) is the rated load (lb) multiplied by the respective distance (ft) from centerline of rotation with all extensions retracted and the inner and outer booms in a horizontal position, per ANSI B30.22.

### 9.5A: DIMENSIONAL DRAWING, 2.6/19T

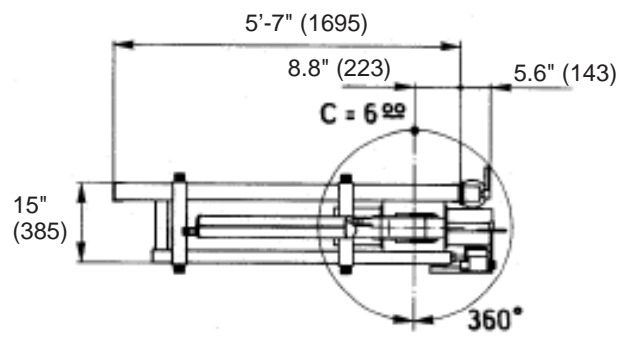
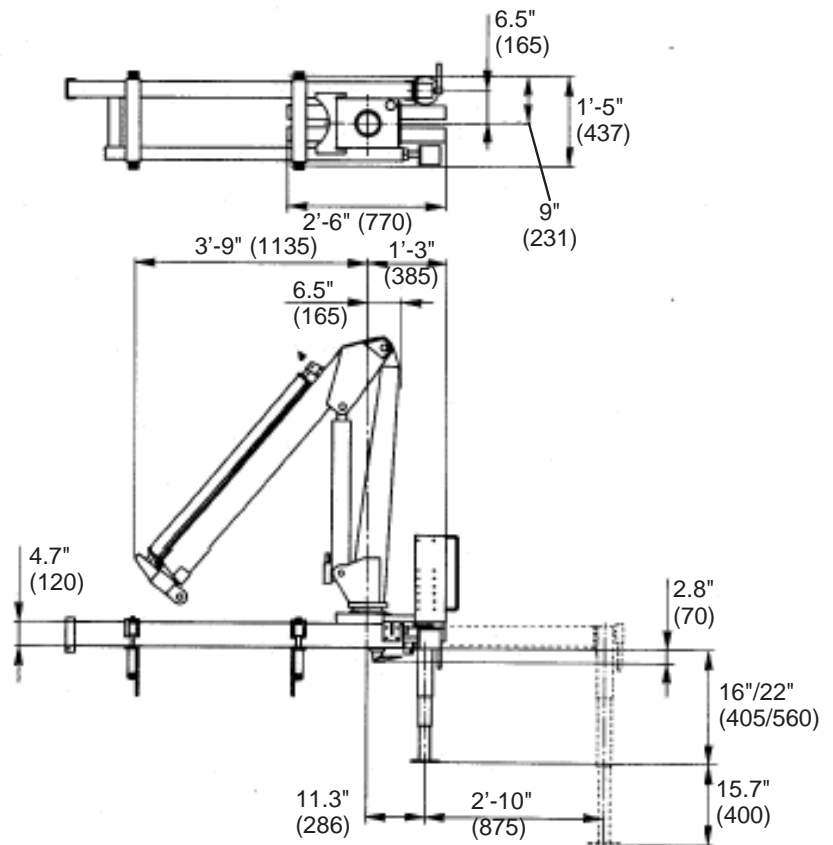
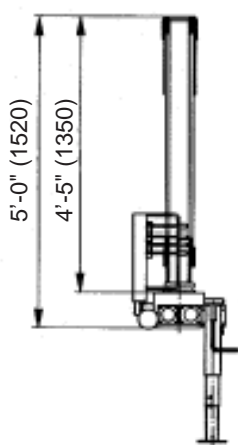
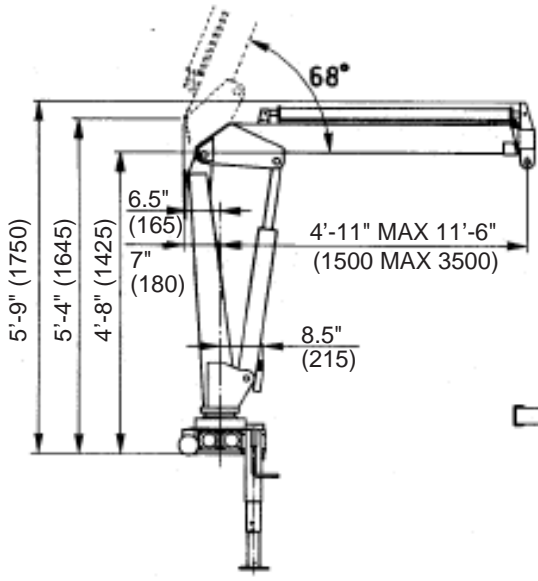

**9.5B: 2.6/19T TECHNICAL DATA**

<b>2.6/19T</b>	<b>2-HYDRAULIC</b>
Crane Rating*	18,806 ft-lb (2.6 tm)
Maximum Horizontal Reach	11' 6" (3.5 m)
Maximum Vertical Reach	16' 1" (4.9 m)
Maximum Capacity	3880 lb (1760 kg)
Max Cap @ Max Reach	1610 lb (730 kg)
Crane Weight	605 lb (275 kg)
Center of Gravity - Stored	
Vertical	15" (380 mm)
Horizontal (C/L RotTo Bridge)	12" (310 mm)
Stabilizer Pad Diameter	5.5" (140 mm)
Crane Storage Height	5' 0" (1520 mm)
Mounting Space	1' 7" (475 mm)
Rotational Torque	2460 ft lb (340 kg-m)
Rotation	360 degrees
Optimum Pump Performance	3.2 gpm (12 L/min)
System Pressure	2683 psi (185 bar)
Oil Capacity in Base	2.8 gal (10.5 L)
Stabilizers	
Extension	2'-10" (875 mm)
Weight	62 lb (28 kg)

**PRESSURE SETTINGS (Continue from here)**

Use a pressure gauge when setting pressures. Check pressure with annual inspection and after all major repairs.

**WORKING PRESURE ON MAIN-RELIEF VALVES AND PORT-RELIEF VALVE**

Main relief valve	A & B-ports	2683 psi (185 bar)
Stabilizer legs, grab, rotator	Up & Down	2540 psi (175 bar)
Extension cylinders	Extend (B-port)	1815 psi (125 bar)
	Retract (A-port)	P
Boom cylinder	Down (B-port)	1815 psi (125 bar)
	Up (A-port)	2683 psi (185 bar)
Rotation system	Right (B-port)	1450 psi (100 bar)
	Left (A-port)	1450 psi (100 bar)

**OPENING PRESURE ON LOAD-HOLDING VALVES**

Boom cylinder	2830 psi (195 bar)
Extension cylinders	3625 psi (250 bar)

PRESURE SETTINGS FOR LOAD-MOMENT LIMITATION + 100% load	2685 psi (185 bar)
PRESURE SETTINGS FOR LOAD-MOMENT LIMITATION + 90% load	2395 psi (165 bar)

\* Crane rating (ft-lb) is the rated load (lb) multiplied by the respective distance (ft) from centerline of rotation with all extensions retracted and the inner and outer booms in a horizontal position, per ANSI B30.22.

## **11.0 REPAIR**

If your crane needs repair, always use an authorized IMT dealer.

When ordering spare parts, know the:

Crane Model                    i.e. Model 1.5/10

Serial Number                i.e. 421397

Reference number of the spare part required.

If you do not have a spare parts manual, contact your dealer to order one.



**IOWA MOLD TOOLING CO., INC.**  
**BOX 189, GARNER, IA 50438-0189**  
**641-923-3711**  
**TECHNICAL SUPPORT FAX: 641-923-2424**