Manual # 99906117

Chassis Wiring Manual

Revised: July 20, 2016



An Oshkosh Corporation Company

IOWA MOLD TOOLING CO., INC.

PO Box 189

Garner, IA 50438

Tel: 641-923-3711 FAX: 641-923-2424

Website: <http://www.imt.com>

Copyright © 2016 Iowa Mold Tooling Co., Inc.
All rights reserved

No part of this publication may be reproduced, stored in a retrieval system, or transmitted in any form or by any means, electronic, mechanical, photocopying, recording or otherwise without the prior written permission of Iowa Mold Tooling Co., Inc.

Iowa Mold Tooling Co., Inc. is an Oshkosh Corporation Company.

Contents

Revisions	ii
Chassis Wiring	3
2016 Ford UR Wiring Schematic (99906091)	4
99906091-1	4
99906091-2	5

SECTION 1

Chassis Wiring

2016 Ford UR Wiring Schematic (99906091)

99906091-1

UNDER HOOD WIRING

(S) INDICATES SWITCHED SIDE OF POWER RELAY MODULE.

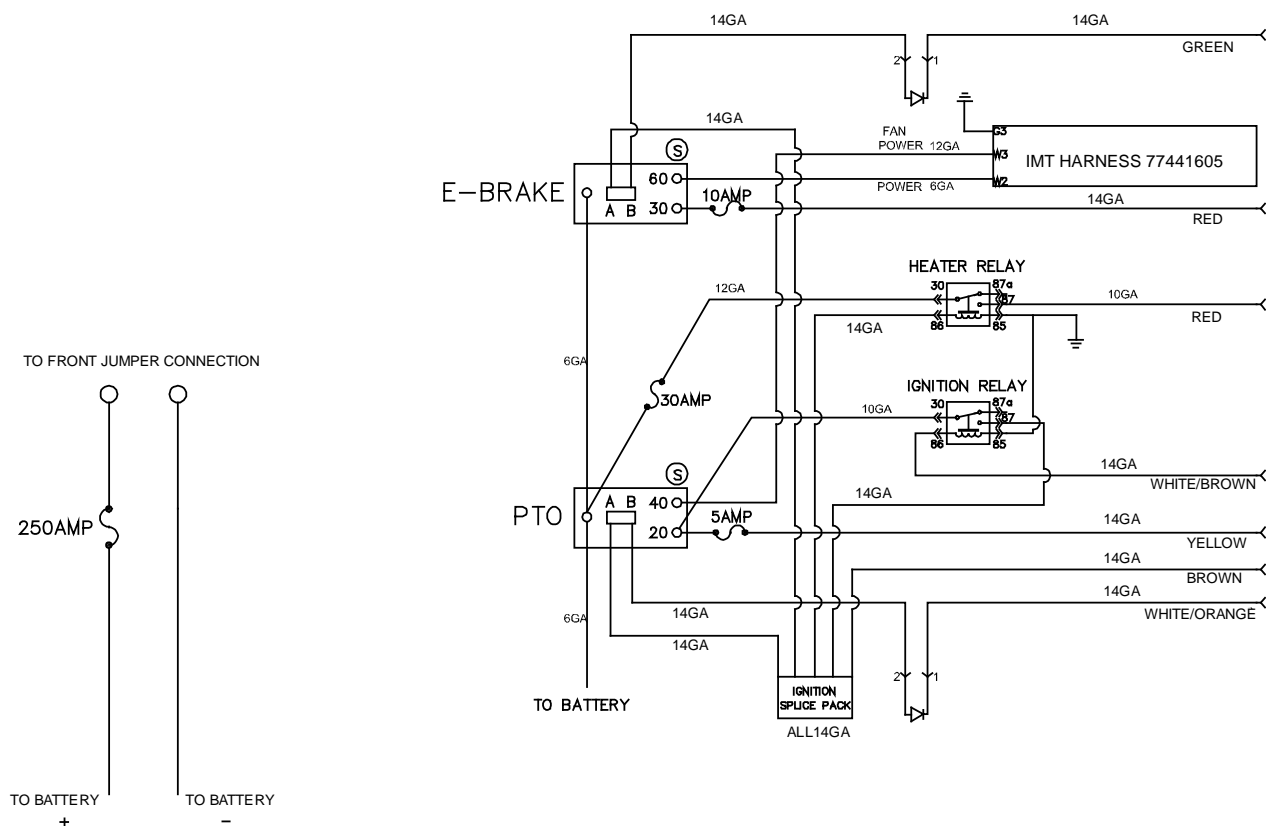

99906091-2

UNDER DASH WIRING

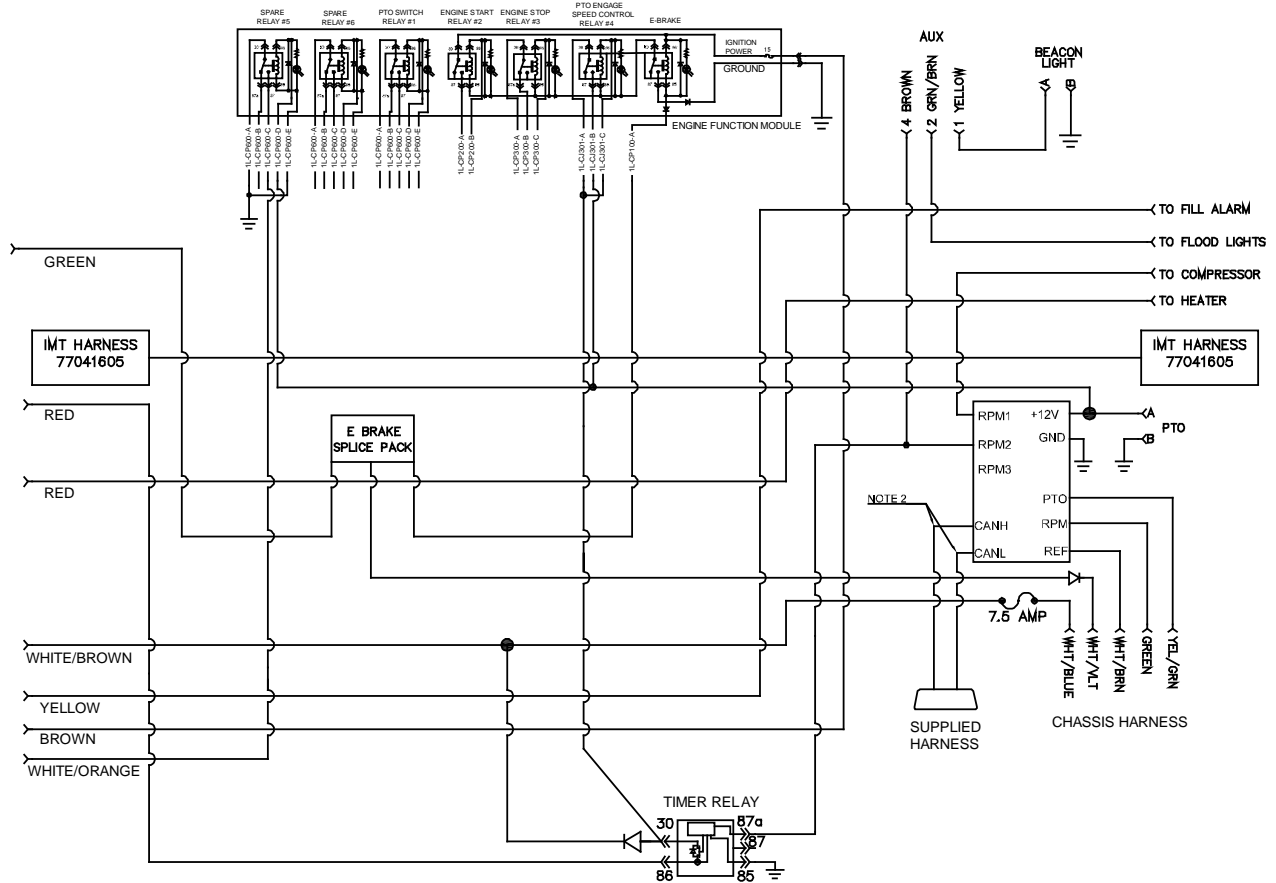

NOTES:

1. ALL WIRE ON 99906091-1 ARE 14 GAUGE UNLESS SPECIFIED OTHERWISE.
2. NOTED WIRES ARE CAN TWISTED PAIR.