



OPERATOR HANDBOOK

DSG 423

**LIQUEFIED PETROLEUM GAS (LPG)
GASOLINE (EFI) &
NATURAL GAS (NG) ENGINES**



**Powertrain Assemblies & Components
Provided By Ford Component Sales**

**EDI 1060020
JULY, 2007**

IMT # 99905334

Used through REFUSE3G3121003. Replaced with MSG425 engine.



WARNING:



WARNING: ENGINE EXHAUST, SOME OF ITS CONSTITUENTS, AND CERTAIN VEHICLE COMPONENTS CONTAIN OR EMIT CHEMICALS KNOWN TO THE STATE OF CALIFORNIA TO CAUSE CANCER AND BIRTH DEFECTS OR OTHER REPRODUCTIVE HARM. IN ADDITION, CERTAIN FLUIDS CONTAINED IN VEHICLES AND CERTAIN PRODUCTS OF COMPONENT WEAR CONTAIN OR EMIT CHEMICALS KNOWN TO THE STATE OF CALIFORNIA TO CAUSE CANCER AND BIRTH DEFECTS OR OTHER REPRODUCTIVE HARM.

FORD DSG-423 ENGINES

GASOLINE (EFI)

LIQUEFIED PETROLEUM GAS (LPG)

NATURAL GAS (NG)

Reproduction in any manner, in whole or in part, is prohibited without the express permission in writing from

Engine Distributors, Inc. (EDI)

EDI policy is one of continuous improvement and while every effort is made to ensure that this publication is up to date and correct in all respects, the right to change prices, specifications and equipment at any time without notice is reserved. Accordingly this publication is not to be regarded as a final description of any individual engine.

CONTENTS

HEALTH & SAFETY	5
General Guidelines:	5
Important Safety Notice.....	5
Notes, Cautions, and Warnings	6
FORWARD	7
ENGINE IDENTIFICATION.....	7
U.S.A. Engine Identification Decal	7
Federal Emissions Warranty Statement.....	8
California Emission Control Warranty Statement.....	8
What Is Covered?	10
PARTS AND SERVICE.....	11
SERVICE LITERATURE	11
BEFORE OPERATING THE ENGINE	12
OPERATING CONTROLS.....	12
Ignition or Isolation Switch	12
Safety Switch (where fitted)	13
Power Take-off (where fitted).....	13
Throttle Control (where fitted)	13
INSTRUMENTS	14
Ammeter (Where Fitted).....	14
Battery Condition Indicator (Where Fitted).....	14
Tachometer (Where Fitted)	14
Hourmeter (Where Fitted)	14
Oil Pressure Gauge (Where Fitted).....	14
Temperature Gauge (Where Fitted).....	15
Malfunction Indicator Light (Where Fitted)	15
Charge Indicator Light (Where Fitted).....	15
Safety Switch Override Button (Where Fitted)	15
Ignition or Isolation Switch	15
Fuel Select Switch (Where Fitted).....	15

CONTENTS

STARTING THE ENGINE	15
Initial Start-up	15
To Start From cold	16
STOPPING THE ENGINE	17
Normal Conditions	17
Abnormal Conditions	17
RUNNING-IN PROCEDURE	17
FUEL RECOMMENDATION	18
Fuel Quality	18
Alcohol Gasoline Blends (Gasohol)	18
LUBRICATION AND MAINTENANCE	20
RECOMMENDED MAINTENANCE SCHEDULES	21
RECOMMENDED MAINTENANCE OPERATIONS	22
Recommended Lubricants	22
Used Engine Oils	23
Change Engine Oil	23
Check Engine Oil Level	24
Renew Engine Oil Filter	24
Gasoline Fuel System - EFI	24
Fuel Filter - EFI	25
Ignition System - DIS	25
Renew Spark Plugs	25
Electronic Actuator	25
Check Condition of Ancillary Drive Belts	26
Check Engine Coolant Level	26
Renew Air Cleaner Element	27
Renew PCV Valve	27

CONTENTS

GENERAL MAINTENANCE INFORMATION	28
Cooling System	28
Draining, Flushing and Filling the Cooling System.....	30
Engine Lubrication System	30
Electrical System.....	31
Generator	31
Storage.....	32
ENGINE SYSTEM CHECK.....	33
SPECIFICATIONS	36
General Specifications	36
Fuel System	36
Lubrication System.....	36
Cooling System	37
Drive Belts.....	37
Electrical System.....	37
Ignition System.....	37
TIGHTENING TORQUES	37
CONVERSION TABLE	38
EDI DISTRIBUTORS	39

HEALTH & SAFETY



WARNING: THE FOLLOWING HEALTH AND SAFETY RECOMMENDATIONS SHOULD BE CAREFULLY OBSERVED.

Carrying out certain operations and handling some substances can be dangerous or harmful to the operator if the correct safety precautions are not observed. Some such precautions are recommended at the appropriate points in this book.

While it is important that these recommended safety precautions are observed, care near machinery is always necessary, and no list can be exhaustive. **ALWAYS BE ON YOUR GUARD!**

General Guidelines:

The following recommendations are for general guidance:

1. Always wear correctly fitting protective clothing which should be laundered regularly. Loose or baggy clothing can be extremely dangerous when working on running engines or machinery. Clothing which becomes impregnated with oil or other substances can constitute a health hazard due to prolonged contact with the skin even through underclothing.
2. So far as practicable, work on or close to engines or machinery only when they are stopped. If this is not practicable, remember to keep tools, test equipment and all parts of the body well away from the moving parts of the engine or equipment—fans, drive belts and pulleys are particularly dangerous. The electric cooling fan used on some installations is actuated automatically when the coolant reaches a specified temperature. For this reason, care should be taken to ensure that the ignition/isolating switch is OFF when working in the vicinity of the fan as an increase in coolant temperature may cause the fan suddenly to operate.
3. Avoid contact with exhaust pipes, exhaust manifolds and silencers when an engine is, or has recently been running; these can be very hot and can cause severe burns.
4. Many liquids used in engines or vehicles are harmful if taken internally or splashed into the eyes. In the event of accidentally swallowing gasoline (petrol), oil, diesel fuel, antifreeze, battery acid etc., **DO NOT ENCOURAGE VOMITING AND OBTAIN QUALIFIED MEDICAL ASSISTANCE IMMEDIATELY.**

Wear protective goggles when handling liquids which are harmful to the eyes; these include ammonia and battery acid. If any of these substances are splashed in the eyes, wash out thoroughly with clean water and **OBTAIN QUALIFIED MEDICAL ASSISTANCE IMMEDIATELY.**

Important Safety Notice

Appropriate service methods and proper repair procedures are essential for the safe, reliable operation of all industrial engines as well as the personal safety of the individual doing the work. This operator handbook provides general directions for accomplishing service and repair work with tested, effective techniques. Following them will help assure reliability.

There are numerous variations in procedures, techniques, tools and parts for servicing equipment, as well as in the skill of the individual doing the work. This

manual cannot possibly anticipate all such variations and provide advice or cautions as to each. Accordingly, anyone who departs from the instructions provided in this Manual must first establish that neither personal safety nor equipment integrity are compromised by the choice of methods, tools or parts.

Notes, Cautions, and Warnings

As you read through the procedures, you will come across NOTES, CAUTIONS, and WARNINGS. Each one is there for a specific purpose. NOTES gives you added information that will help you to complete a particular procedure. CAUTIONS are given to prevent you from making an error that could damage the equipment. WARNINGS remind you to be especially careful in those areas where carelessness can cause personal injury. The following list contains some general WARNINGS that you should follow when you work on the equipment.



GENERAL WARNINGS:

- Always wear safety glasses for eye protection.
- Use safety stands whenever a procedure requires you to be under the equipment.
- Be sure that the ignition switch is always in the OFF position, unless otherwise required by the procedure.
- Set the parking brake (if equipped) when working on the equipment. If you have an automatic transmission, set it in PARK REVERSE (engine off) or NEUTRAL (engine on) unless instructed otherwise for a specific operation. Place wood blocks (4" x 4" or larger) to the front and rear surfaces of the tires to provide further restraint from inadvertent equipment movement.
- Operate the engine only in a well ventilated area to avoid the danger of carbon monoxide.
- Keep yourself and your clothing away from moving parts when the engine is running, especially the fan belts.
- To prevent serious burns, avoid contact with hot metal parts such as the radiator, exhaust manifold, tail pipe, catalytic converter and muffler.
- Do not smoke while working on the equipment.
- To reduce the risk of injury, always remove rings, watches, loose hanging jewelry, and loose clothing before beginning to work on the equipment. Tie long hair securely behind the head.
- Keep hands and other objects clear of the radiator fan blades. Electric cooling fans can start to operate at any time by an increase in underhood temperatures, even though the ignition is in the OFF position. Therefore, care should be taken to ensure that the electric cooling fan is completely disconnected when working under the hood.

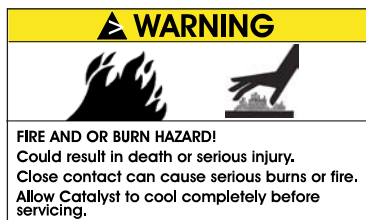

FORWARD

This book contains operating and maintenance instructions for the engine(s) listed on the title page.

The life of your engine unit and the delivery of the high performance built into it will depend on the care it receives throughout its life. It is the operator's responsibility to ensure that the engine is correctly operated and that the maintenance operations outlined in this book are carried out regularly after the specified hours of operation have been reached. We consider it to be in your interests to enlist the aid of an authorized EDI Distributor, not only when repairs are required but also for regular maintenance. Distributors are listed at the back of this handbook.

Regular maintenance will result in minimal operating costs.

Engines manufactured by Ford Motor Company are available through EDI Distributors. When in need of parts or service, contact your local EDI Authorized Distributor.

Where the terms "Right" or "Left" occur in this publication, they refer to the respective sides of the engine when viewed from the rear or flywheel end.

Pistons and valves are numbered from the front or timing cover end of the engine commencing at No. 1.

You may find that your engine assembly includes optional equipment not specifically covered in the following text. Nevertheless, the maintenance procedures outlined in this book still apply to your engine

ENGINE IDENTIFICATION

It is important that you have as complete identification of the engine as possible in order to provide the correct replacement parts. New engines being shipped include a standard parts listing describing the parts which does not tell the owner the part number. It remains a distributor function to identify the part number.

The key to identifying the engine is the identification decal mounted on the engine rocker cover. That decal provides not only the engine serial number, but also the exact model or type, options and S.O. (Special Order). The combination of that data permits you to isolate the precise engine, build level and customer so you can determine the correct replacement parts.

U.S.A. Engine Identification Decal

An identification Decal is affixed to the valve cover of the engine. The decal contains the engine serial number which identifies this unit from all others. Use all numbers when seeking information or ordering replacement parts for this engine.

ENGINE DISTRIBUTORS INC. 
Model No: DSG423
Serial No: <input type="text"/>

Federal Emissions Warranty Statement

Engine Distributors, Inc. (EDI) warrants that your new **(2006 or later model year)** off-road large spark-ignition (LSI) is designed, built, and equipped to meet the applicable EPA emissions requirements and is free from defects in factory supplied materials and workmanship that could prevent it from conforming with these requirements.

EDI provides the following emissions warranty coverage for your new off-road LSI engine:

- Three (3) years or 2500 hours, whichever occurs first, for emissions-related parts (see list below).
- Five (5) years or 3500 hours, whichever occurs first, for high-priced emissions-related parts (see list below).

In cases where the Original Equipment Manufacturer has sourced components from suppliers other than EDI, the Original Equipment Manufacturer will be responsible for warranty related to these components. These parts are noted in the "What is Covered" section with the statement "(Supplied and Warranted by Original Equipment Manufacturer)".

You will not be charged for repair, replacement, or adjustment of defective emissions-related parts listed below.

Concerning parts that should be replaced during scheduled maintenance, these parts remain under warranty until the first scheduled maintenance specified in the maintenance schedule or the applicable coverage period listed above, whichever occurs first.

California Emission Control Warranty Statement

Your Warranty Rights and Obligations

The **California Air Resources Board** and Engine Distributors, Inc. (EDI) are pleased to explain the **emission control system warranty** on your **2006 or later model year** compliant certified off-road large spark-ignition engine. In California, new off-road large spark-ignition (LSI) engines must be designed, built and equipped to meet the State's stringent anti-smog standards. EDI must warrant the emission control system on your compliant certified engine for the periods of time listed below provided there has been no abuse, neglect or improper maintenance of your engine.

Your emission control system may include parts such as the carburetor, regulator, or fuel-injection system, ignition system, engine computer unit (ECM), catalytic converter, and air induction system. Also included may be sensors, hoses, belts, connectors and other emission-related assemblies.

Where a warrantable condition exists, EDI will repair your LSI compliant certified engine at no cost to you including diagnosis, parts and labor.

In cases where the Original Equipment Manufacturer has sourced components from suppliers other than EDI, the Original Equipment Manufacturer will be responsible for warranty related to these components. These parts are noted in the "What is Covered" section with the statement "(Supplied and Warranted by Original Equipment Manufacturer)".

Manufacturer's Warranty Coverage:

The **2006 or later** off-road large spark-ignition compliant certified engines are warranted for **three (3) years or 2500 hours, whichever occurs first**. High cost emission related parts are warranted for **five (5) years or 3500 hours, whichever occurs first**. If any emission-related part on your engine fails to perform as designed within the warranty period, the part will be repaired or replaced by EDI (see list below).

Owner's Warranty Responsibilities:

As the off-road LSI engine owner, you are responsible for the performance of the **required maintenance listed in your owner's manual**. EDI recommends that you retain all receipts covering maintenance on your off-road engine, but EDI cannot deny warranty solely for the lack of receipts or for your failure to ensure the performance of all scheduled maintenance.

As the off-road large spark-ignition engine owner, you should however be aware that EDI may deny you warranty coverage if your off-road large spark-ignition engine or a part has failed due to abuse, neglect, improper maintenance or unapproved modifications.

Your compliant certified engine is designed to operate on **gasoline or liquefied propane gas** when properly equipped. Use of any other fuel may result in your engine no longer operating in compliance with California's emissions requirements.

You are responsible for initiating the warranty process. The ARB suggests that you present your off-road large spark-ignition engine to an EDI distributor as soon as a problem exists. The warranty repairs should be completed by an authorized EDI distributor or service dealer as expeditiously as possible.

If you have any questions regarding your warranty rights and responsibilities, you should contact an EDI customer service representative at

1 800 220 2700

What Is Covered?

The Federal and California emission warranties cover the following parts.

1. Air / Fuel Feedback Control System and Sensors
2. Air Induction System (Supplied and Warranted by Equipment Manufacturer)
3. Carburetor system (internal parts and/or pressure regulator or fuel mixer or injection system)
4. Catalytic Converter
5. Electronic Engine Control Sensors and Switches
6. Electronic Ignition System
7. Exhaust Manifold and Gaskets
8. Exhaust Pipe between Exhaust Manifold and Catalyst (Supplied and Warranted by Equipment Manufacturer)
9. Fuel Injection System
10. Fuel Injector Supply Manifold
11. Fuel Pump
12. Fuel Pressure Regulator
13. Gaseous Fuel System Assembly
14. Idle Air Control Valve Block off Plate and Gasket
15. Ignition Coil and/or Control Module
16. Intake Manifold and Gaskets
17. Malfunction Indicator Lamp
18. PCV System and Oil Filler Cap
19. Engine Performance Module
20. Solenoid Assembly - Carburetor Feedback Control
21. Spark Control Components
22. Spark Plugs and Ignition Wires
23. Synchronizer Assembly
24. Thermostat Assembly
25. Throttle Body Assembly and Gaskets

NOTE: All emissions related bulbs, hoses, clamps, brackets, tubes, gaskets, seals, belts, connectors, fuel lines, and wiring harnesses used with the above components are also covered.

Components That Are Considered High Priced Parts

1. Catalytic Converter
2. Catalytic Converter Muffler
3. Engine Performance Module
4. Engine Wiring Harness
5. Fuel System (Gaseous) - Mixer
6. Fuel System (Gaseous) - Regulator, Fuel Pressure
7. Fuel System (Gaseous) - Trimming Device

PARTS AND SERVICE

Replacement parts can be obtained through your local EDI Distributors listed in the back portion of this handbook. They also may be found in the yellow pages under “Engines” or contact EDI at: 1-800 220 2700.

EDI Distributors are equipped to perform major and minor repairs. They are anxious to see that all of your maintenance and service needs are quickly and courteously completed.

SERVICE LITERATURE

A service manual can be purchased from your EDI distributor. This publication will provide the necessary servicing and overhaul information for your engine.

- SERVICE MANUAL EDI 1060040
- PART LIST EDI 1060030
- OPERATORS HANDBOOK EDI 1060020

BEFORE OPERATING THE ENGINE

1. Before operating a new engine it should be thoroughly inspected to ensure that during transit and installation it has not suffered damage likely to affect its subsequent operation. Controls and instruments should be studied carefully in order that their functions are thoroughly understood.
2. Check that the radiator (where applicable) is full and top off as necessary -- Refer to "Cooling System" on page 28 for recommended coolant mixtures.
3. In the case of marine/industrial engines, ensure that there is coolant in the degas/expansion tank (where applicable).

CAUTION: Under no circumstances may the engine be started without liquid in the cooling system.

4. Check the engine oil level and top up or fill as necessary -- Refer to "Check Engine Oil Level" on page 24. For the correct type and grade of oil -- Refer to "Recommended Lubricants" on page 22.
5. Ensure that the battery is fully charged and, if necessary, top up with distilled water.

NOTE: Ensure that ALL wiring ground connections are properly made to a clean point on the chassis/frame.

6. The engine must be started in accordance with the starting instructions -- Refer to "STARTING THE ENGINE" on page 15.

OPERATING CONTROLS

Ignition or Isolation Switch

An ignition or isolation switch is usually fitted which connects the engine starter motor and other electrical equipment to the battery. The switch can be moved to any of the four positions shown by rotating the key. These positions are:

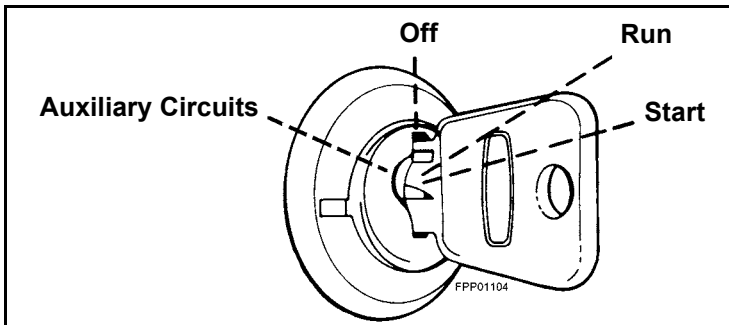

1. Auxiliary Circuits - When moved to this position the auxiliary electrical equipment such as radios and heater fans, can be operated without also connecting the starting circuit with the battery.
2. Off - When set to this position, the switch disconnects the auxiliary electrical equipment and the starting circuit from the battery. The key can be removed from the switch when it is in this position; this will help to prevent unauthorized operation of the engine.
3. Run - This switch position connects the auxiliary circuits as described previously, and the alternator is given initial excitation via the battery.

4. Start - In this position, the starter solenoid is energized and the starter motor cranks the engine. The switch, when released, automatically returns to the RUN position.

Safety Switch (where fitted)

A low oil pressure/high water temperature safety switch may be fitted. This automatically shuts off the ignition when the oil pressure drops below a pre-set value, or when the water temperature rises above a pre-set value. A button on the instrument panel is used to override the safety switch when starting the engine. The safety switch override button must be depressed to start the engine.

NOTE: With safety shut-down incorporated, oil pressure below 6 psi and/or coolant temperature goes above 250° F, will shut-down ignition system. Corrective action must be taken and key recycled to restart.

Power Take-off (where fitted)

The power take-off control handle allows engagement and disengagement of the power take-off clutch. Moving the lever towards the engine engages the clutch and moving the lever away from the engine disengages the clutch.

When moving the handle to engage the clutch and pick up the load, do so in a smooth manner. Moving the clutch handle too slowly will cause slippage and wear, while moving it too fast will cause quick engagement and possible damage to the power take-off, engine or driven equipment. The normal force required to engage the clutch is 55 lbf (245 N) for the over-centre type and 25 lbf (110 N) for the spring loaded type.

Throttle Control (where fitted)

The throttle control adjusts engine speed. Initial engine speed adjustment is obtained by pressing the throttle control release button while pulling the throttle knob out to increase the engine speed or pushing it in to decrease the engine speed.

A final fine speed adjustment is obtained by turning the throttle control counterclockwise to increase engine speed or clockwise to decrease engine speed.

INSTRUMENTS

Your Engine Distributors, Inc. (EDI) Powered Equipment will have been fitted with instruments selected by the manufacturer. The types of instruments most likely to be encountered are detailed here. A typical instrument panel is shown below.

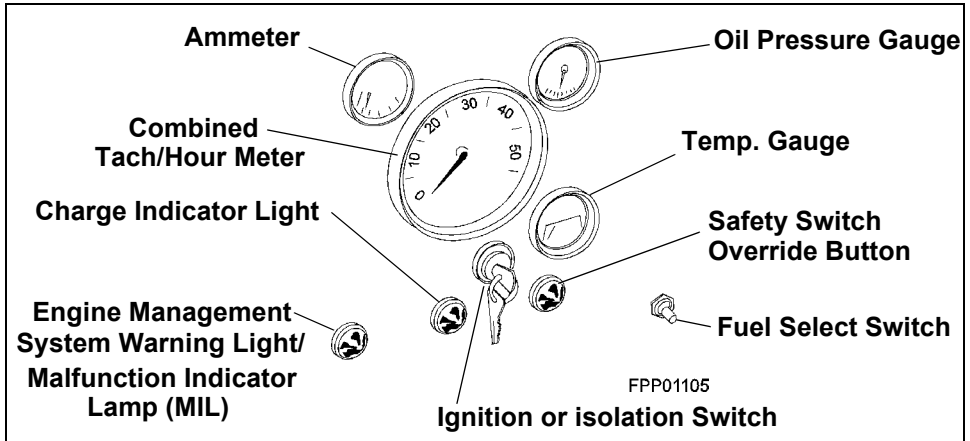

Ammeter (Where Fitted)

This instrument registers the charging current which is being passed to the battery from the alternator. It also registers a discharge equivalent to the amount of current being used by the electrical equipment when the alternator is not charging.

Battery Condition Indicator (Where Fitted)

This is sometimes fitted instead of an ammeter and measures the battery voltage thus indicating the state of charge of the battery.

Tachometer (Where Fitted)

The tachometer indicates the actual engine running speed in crankshaft revolutions per minute.

Hourmeter (Where Fitted)

This instrument records the number of hours of operation which the engine has completed at the rated rpm. It is frequently combined with the tachometer and is used to determine when an engine service operation is required. If no hourmeter is fitted, a log should be kept.

Oil Pressure Gauge (Where Fitted)

The oil pressure gauge registers the lubricating system pressure in bar (kgf/cm^2 or lbf/in^2) and should be frequently observed to ensure that the system is functioning correctly.

Temperature Gauge (Where Fitted)

The temperature gauge enables a close check to be kept on the coolant temperatures.

Malfunction Indicator Light (Where Fitted)

Used on all industrial engines. This light will illuminate whenever there is an engine malfunction such as low oil pressure, high engine temperature, fuel injection system fault. The engine can be programmed to shut down in the event of a malfunction.

Charge Indicator Light (Where Fitted)

If an alternator is fitted to your engine, a charge indicator light will also be fitted. The light will glow when the isolating switch is in the RUN position with the engine stationary and will therefore serve as a reminder either to turn the isolating switch to the OFF position or to start the engine. Once the engine has started, the charge indicator light should cease glowing.

Safety Switch Override Button (Where Fitted)

This must be depressed when starting the engine, as the safety switch operates when the oil pressure falls due to the engine stopping -- Refer to "Safety Switch (where fitted)" on page 13.

Ignition or Isolation Switch

-- Refer to "Ignition or Isolation Switch" on page 12.

Fuel Select Switch (Where Fitted)

This switch is incorporated for use with dual fuels. Switch must point to selection of fuel being used.

STARTING THE ENGINE



WARNING: ALL INTERNAL COMBUSTION ENGINES GIVE OFF VARIOUS FUMES AND GASES WHILE RUNNING. DO NOT START OR RUN THE ENGINE IN A CLOSED OR POORLY VENTILATED BUILDING WHERE THE EXHAUST GASES CAN ACCUMULATE. AVOID BREATHING THESE GASES AS THEY MAY CONTAIN POISONOUS CARBON MONOXIDE WHICH CAN ENDANGER YOUR HEALTH OR LIFE IF INHALED STEADILY FOR EVEN A FEW MINUTES.

Initial Start-up

On initial start-up follow the daily regular maintenance schedule illustration -- Refer to "RECOMMENDED MAINTENANCE SCHEDULES" on page 21.

To Start From cold

1. Where possible, disconnect the driven equipment, eg, fully depress the clutch where a manual transmission is fitted.

If your unit is equipped with the engine warning light system, always turn the ignition switch to the ON position to make sure that each warning light is operating before starting engine.

2. Switch on the ignition and operate the starter motor until the engine fires.

NOTE: Where a safety switch is fitted, the override button must be depressed while the engine is being cranked.

3. Set the throttle to give a fast idle speed until normal operating temperature is reached (where fitted).

NOTE: For EFI Governor application there is no throttle cable. Turn key to crank to start engine. When engine starts release key to run position. The ECM will adjust speed for cold start and altitude automatically.

CAUTION: If the engine stalls or falters in starting, wait 3-4 seconds before re-engaging starter. This will prevent possible damage to the starter or engine. The starter should not operate for periods longer than 30 seconds at a time. An interval of at least two minutes should be observed between such cranking periods to protect the starter from overheating.

STOPPING THE ENGINE

Normal Conditions

Following normal operating conditions, lower the engine speed to idle, disengage the clutch, and then turn the ignition switch to the OFF position. If the engine has been running under high power, let it run at fast idle speed a few minutes to cool the engine down.

Abnormal Conditions

Under abnormally overheated conditions, the engine may continue to run after the ignition switch is turned off. If this case is ever encountered, turn on the ignition switch immediately and allow the engine to idle until it has cooled enough to stop. If the engine is overheated due to loss of coolant, it is best to stop the engine immediately, if necessary by applying the load. Add engine oil if necessary, then after the engine has returned to a normal temperature, add coolant slowly until the radiator is full.



WARNING: TO REDUCE THE RISK OF INJURY WHEN CHECKING A HOT ENGINE. COVER THE RADIATOR CAP IN A THICK CLOTH AND TURN IT SLOWLY COUNTERCLOCKWISE TO THE FIRST STOP. AFTER THE PRESSURE HAS BEEN COMPLETELY RELEASED, PRESS THE CAP DOWNWARD AND FINISH REMOVING THE CAP.

The above instructions also apply to engines that stop due to operation of the low oil pressure/high water temperature safety switch. However, if the engine stops due to low oil pressure, do not restart until the cause has been determined and corrected -- Refer to "Recommended Lubricants" on page 22.

RUNNING-IN PROCEDURE

A new or reconditioned engine must not be run at high speeds or on full load for the first 25 hours. The load and speed may be increased to a maximum over this period. After the first 50 hours running, carry out the maintenance operations listed -- Refer to "RECOMMENDED MAINTENANCE SCHEDULES" on page 21.

Check the instruments frequently and keep the coolant and oil filled to their recommended levels.

FUEL RECOMMENDATION

This engine is designed to operate on dry fuel such as LPG Grade HD5 or NG (1050 BTU/ft.³).

CAUTION: Use of commercial and non-commercial fuels rated lower than the grades specified above may cause persistent, heavy spark knock, which can lead to engine damage. If your engine knocks heavily, or if you hear continuous spark knock while maintaining constant operating speeds, consult your distributor or another qualified technician.

Fuel Quality

Using a high quality gasoline will help maintain the power, fuel economy and emissions performance of your engine. A properly formulated gasoline will be comprised of well refined hydrocarbons and chemical additives and will perform the following functions:

- Minimize varnish, lacquer, and other induction system deposits.
- Prevent gum formation or other deterioration during storage.
- Protect fuel tank and other fuel system components from corrosion or degradation.
- Provide the correct seasonally and geographically adjusted volatility. This will provide easy starting in the winter and avoid vapor lock in the summer.
- Avoid fuel system icing.

In addition, the fuel will be free of water, debris, and other impurities.

We also recommend that the fuel supply be kept fresh; when the equipment is in storage (especially in hot weather), the fuel tank should be kept at least 3/4 full.

If you anticipate storage of your engine in excess of two months, consult your distributor or other qualified technician. Also refer to the information on storage in the "Maintenance Instructions" section of this manual.

Alcohol Gasoline Blends (Gasohol)

Gasohol is a mixture of gasoline and ethanol or methanol.

CAUTION: If not properly formulated with appropriate cosolvents and corrosion inhibitors, such blends may cause performance problems or damage emissions and fuel system materials. Discontinue use if performance problems occur. To avoid jeopardizing the engine warranty and incurring unnecessary repair cost, do not use blends containing more than 10% ethanol by volume or 5% methanol by volume, or blends that do not contain cosolvents and corrosion inhibitors. Do not use such fuels unless they are unleaded.

Ethanol (C₈H₁₆) is an alcohol based fuel. There are basically two ways to produce ethanol. One way is the fermentative method. This method is based on the fermentation of ethanol from corn, sugar cane, cellulose, and other alternative crops. The other way is the catalytic hydrolysis of ethylene, a petroleum product, is the primary synthetic method. Compared to gasoline the energy content of ethanol is 66%. Ford engines should operate satisfactory on gasohol blends using unleaded gasoline and containing no more than 10% ethanol by volume. Cosolvents and corrosion inhibitors must also be added. The blend must also have an octane (anti-knock) index of 87 or 89, reference to engine specification section.

Methanol (CH₃OH) is also an alcohol based fuel. It can be produced in several ways. One is from natural gas. This process is an inefficient nonviable method of production. Another method is from coal. The problem with methanol produced from coal is that it yields a higher carbon dioxide emission. However coal reserves are much greater than oil or natural gas. A long-term supply of methanol can also be produced from biomass and urban refuse. The biomass process to methanol is prohibitive due to the amount of nonrenewable energy input required for conversion. Compared to gasoline the energy content of methanol is only 49%. Ford engines should operate satisfactory on gasohol blends using unleaded gasoline and containing no more than 5% methanol by volume. Cosolvents and corrosion inhibitors must also be added. The blend must also have an octane (anti-knock) index of 87 or 89, reference to engine specification section.

Gasohol, a mixture of gasoline and ethanol (grain alcohol), is available in some areas outside Europe. Ford engines should operate satisfactory on gasohol blends containing no more than 10% ethanol by volume and having an octane (anti knock) index of 87 or 89, reference engine specifications.

CAUTION: In some cases, methanol (wood alcohol) or other alcohols may be added to gasoline. Ford engines should operate satisfactory on blends containing up to 5% methanol by volume when cosolvents and other necessary additives are used. If not properly formulated with appropriate cosolvents and corrosion inhibitors, such blends may cause performance problems or damage emissions and fuel system materials. Insufficient data is available to insure the suitability of all methanol/gasoline blends at this time. To avoid jeopardizing your engine warranty or incurring unnecessary repairs costs, DO NOT USE blends containing more than 5% methanol by volume, or blends that do not contain cosolvents and corrosion inhibitors.

If you are uncertain as to the presence of alcohols in the gasoline you are purchasing, check the label on the pump or ask the station attendant.

CAUTION: Discontinue use of any gasohol or alcohol/gasoline blend if performance problems occur. Do not use such fuels unless they are UNLEADED.

NOTE: It is highly recommended that a Fuel Stabilizer, Ford Part Number E8AZ-19C544-A or an equivalent additive be used for any length of storage. It is imperative in any application where the fuel will not be consumed within thirty days. Refer to "STORAGE" in this section for further information.

LUBRICATION AND MAINTENANCE

The importance of correct lubrication, periodic inspection and adjustment cannot be over-emphasized. It will determine, to a very large extent, the service the engine will give. Detailed instructions regarding this maintenance are given in the following pages.

Your Authorized EDI Distributor listed in the back section of this manual, will be pleased to carry out this regular maintenance for you. The various maintenance operations are listed -- Refer to "RECOMMENDED MAINTENANCE SCHEDULES" on page 21.

When carrying out any of the following maintenance operations, any fault or malfunction should be reported immediately to the supervisor or person responsible for engine overhaul or repair.

The following Maintenance Schedules give the maximum recommended service periods. Since operating conditions can vary, it may be advisable to carry out some operations, for example, changing the engine oil, at an interim period. Your operating experience is the best guide for determining this time.

RECOMMENDED MAINTENANCE SCHEDULES

<div style="text-align: center;"> <div style="border: 1px solid black; padding: 2px; display: inline-block; margin-bottom: 5px;">Hours Running Or Miles Driven</div> <div style="border: 1px solid black; padding: 2px; display: inline-block; margin-top: 10px;">Maintenance Operation</div> </div>	Daily	After 1st 50 hrs. (2500 km or 1500 miles)	Every 100 hrs. (5000 km or 3000 miles)	Every 200 hrs. (10,000 km or 6000 miles)	Every 400 hrs. (20,000 km or 12,000 miles)	Every 800 hrs. (40,000 km or 24,000 miles)	Every 4 years max.	Details on Page #
	Check engine oil level and top up if necessary	X	X	X	X	X	X	
Check engine coolant level and top up if necessary with correct mixture	X	X	X	X	X	X		26
Check visually for oil, fuel or coolant leaks	X	X	X	X	X	X		
Lubricate PTO release bearing	X	X	X	X	X	X		
Check all instruments, controls and warning lights. Check hot and cold starting functions	X	X	X	X	X	X		
Check coolant, oil, fuel, exhaust and vacuum hoses/pipes for leaks, damage, deterioration and correct routing. Check all visible electrical wiring for security, correct routing and evidence of chafing or heat damage		X	X	X	X	X		
Change engine oil and renew engine oil filter					X	X		23
Lubricate PTO bearings			X	X	X	X		
Check condition and adjust tension of drive belt(s)				X	X	X		26
*Check gasoline fuel filter element and renew as necessary				X	X	X		
*Check dry fuel filter element and renew as necessary				X	X	X		
Renew air cleaner element					X	X		27
Spark plugs: Clean, adjust and test or replace					X	X		25
*Check all nuts & bolts for tightness					X	X		
*Adjust PTO clutch release & shaft bearings					X	X		
Renew PCV valve						X		27
Clean PCV hoses, tubes and fittings						X		27
Clean coolant filler cap. Renew cap if seal has deteriorated							X	

*It is recommended that this operation is carried out by an authorized EDI Distributor. Depending upon the quality of the fuel used, it may be necessary to renew the filter element more frequently.

RECOMMENDED MAINTENANCE OPERATIONS

Recommended Lubricants

CAUTION: Do not use supplemental oil additives or other engine treatments. They are unnecessary and could, under certain conditions, lead to engine damage which is not covered by EDI warranty.

Lubricating oil cleanliness is vital for the successful operation of your engine. The oil should be stored under the cleanest possible conditions. When changing or topping-up engine oil use only clean receptacles. Do not allow the oil to come into contact with rubber hoses on the engine.

-30°	-20°	-15°	-10°	0°	+30°	+40°
←	←	←	←	←	←	←
←	←	←	←	←	←	←
←	←	←	←	←	←	←
	←	←	←	←	←	←
	←	←	←	←	←	←

CAUTION: Use Ford/Motorcraft “Formula E” SAE 5W-20 engine oil or equivalent that meets Ford Specification WSS-M2C930-A (API Classification – SJ). If SJ oils are not available, SH oils are acceptable. Use only engine oil displaying the American Petroleum Institute Certification Mark on the front of the container, or API specification SH, or SJ.

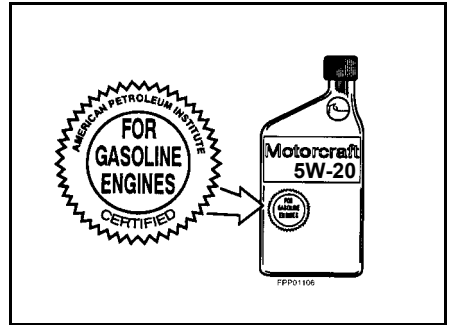

NOTE: EDI industrial engines are designed to perform with engine oils that are licensed by the American Petroleum Institute (API), and oils carrying the most current API classification should be used. API classifications are broken into two categories, gasoline and diesel engines. API’s classification is designated by a two letter system. The first letter, the prefix, designates gasoline or diesel. An “S” designates gasoline and a “C” designates diesel. The second letter in the system designates the level of the classification. It should be noted that alternative fuel engines fall into the “gasoline” API category.

Gasoline engines that are converted for LPG or Natural Gas applications must use oils labeled SH and/or SJ. Do not use oils that are specifically formulated for Diesel Engines only. CC or CD classification, even when labeled Heavy Duty or for Natural Gas Engines, are not acceptable. The use of SAE 5W-20 is recommended for all temperatures:

Used Engine Oils



WARNING: PROLONGED AND REPEATED CONTACT MAY CAUSE SERIOUS SKIN DISORDERS INCLUDING DERMATITIS AND SKIN CANCER.

WARNING: AVOID EXCESSIVE CONTACT—WASH THOROUGHLY AFTER CONTACT. KEEP OUT OF THE REACH OF CHILDREN.

WARNING: PROTECT THE ENVIRONMENT: IT IS ILLEGAL TO POLLUTE DRAINS, WATER COURSES OR SOIL. USE AUTHORIZED FACILITIES FOR DISPOSAL. IF IN DOUBT, CONTACT YOUR LOCAL AUTHORITY FOR ADVICE.



WARNING: DO NOT HANDLE A HOT OIL FILTER WITH BARE HANDS. CONTINUOUS CONTACT WITH USED MOTOR OIL HAS CAUSED SKIN CANCER IN LABORATORY MICE. PROTECT YOUR SKIN BY WASHING WITH SOAP AND WATER IMMEDIATELY AFTER CONTACT.

Change Engine Oil

1. Warm the engine to normal operating temperature.
2. Make sure that the equipment is standing level and that the engine is stopped.
3. Obtain a sufficiently large draining pan to accommodate the engine oil -- Refer to "Service Oil fill capacity (including filter):" on page 36.
4. Remove the oil filler cap from the rocker cover, remove the drain plug from the oil pan and drain the oil into the draining pan.

NOTE: Modern high performance oils have a cleaning action on the engine which may turn the oil dark, but does not necessarily indicate inadequate oil changes.

5. Replace and tighten the drain plug, then fill the engine via the filler neck in the rocker cover with the correct quantity of oil -- Refer to "SPECIFICATIONS" on page 36.
6. Replace the oil filler cap and run the engine for no more than 30 seconds.
7. Check the oil level as described in the following section.

Check Engine Oil Level

1. Make sure the equipment is standing level and that the engine is stopped.
2. Pull out the dipstick and wipe it with a clean rag.
3. Insert the dipstick fully and again remove it. At no time should the level of the oil fall below the lower mark on the dipstick.
4. If necessary, top up to the dipstick higher mark with an approved type and grade of oil.
5. Replace the dipstick, ensuring that it is fully inserted into its tube to maintain a sealed crankcase condition

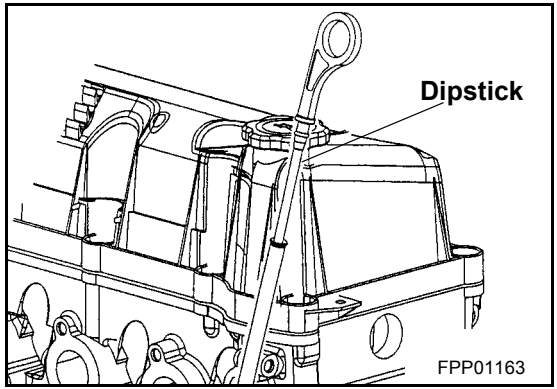

Renew Engine Oil Filter

Your engine is equipped with a Motorcraft oil filter. A filter of this quality should be used throughout the life of the engine. It is designed to protect your engine by filtering harmful abrasive and sludgy particles without clogging up or blocking the flow of the oil to vital engine parts. This filter is especially designed for use in engines built by Ford to give successful operation with the recommended oil filter change intervals. Contact your nearest EDI distributor listed in the back section to obtain the correct filter. Before commencing, place a drain pan beneath the filter to catch any spilt oil.

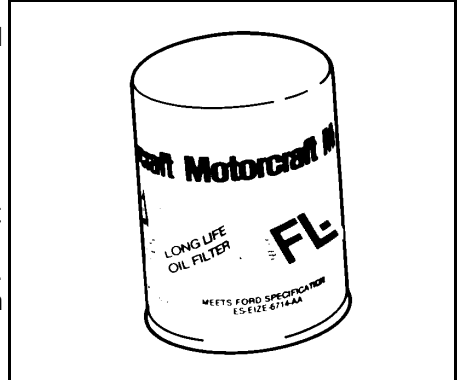

1. Using a suitable strap wrench, unscrew the oil filter canister.
2. Thoroughly clean oil filter housing face.
3. Partly pre-fill the new filter with clean engine oil of the correct type and grade. Apply a thin film of clean engine oil to the oil filter sealing ring.
4. Screw on new oil filter canister until sealing ring abuts the filter head and tighten a further 1/2 turn. Do NOT use a strap wrench or similar tool to tighten the filter canister.
5. Run engine and check for any leaks from oil filter.
6. Stop engine, allow oil to settle and top up as necessary.

Gasoline Fuel System - EFI

In the event that your engine is equipped with an EFI (Electronic Fuel Injection) system follow normal maintenance service. Any necessary service repairs should be made by your EDI Distributor. The adjusting procedure requires the use of tools which are not readily available to consumers. Please contact EDI Distributors listed in the back section of this manual.

Fuel Filter - EFI

The fuel filter is located between the fuel tank and the fuel pump.

Ignition System - DIS

The Distributorless Ignition System (DIS) used on this engine does not have a distributor or vacuum advance mechanism. Ignition timing is set by design and cannot be readily changed. In the event that the engine is converted to alternative fuels, the timing can be re-set by trained technicians. Please contact an EDI Distributor listed at the back of this manual.

Renew Spark Plugs

Spark plugs are located in the top center of the cylinder head. The ignition system is a Coil-on-plug design, which eliminates the need for a distributor, rotor and wires. Each spark plug is powered by it's own coil located directly above the spark plug. Access to the spark plug is gained by removing the coil retaining bolt and coil.

Electronic Actuator

In the event that your engine is equipped with an electronic actuator, no adjustment can be made.

Check Condition of Ancillary Drive Belts



WARNING: ENGINE SHOULD BE STOPPED AND ANY REMOTE STARTER DISABLED BEFORE CHECKING BELTS.

The serpentine ancillary belt used to drive the generator and water pump, is tensioned automatically and does not require adjustment.

The belts should be visually inspected for signs of wear or damage. It should be renewed if necessary. Refer to Service Manual.

NOTE: May be purchased from your local EDI Distributor listed on the back of this handbook.

Check Engine Coolant Level



WARNING: TO REDUCE THE RISK OF INJURY WHEN CHECKING A HOT ENGINE. COVER THE RADIATOR CAP WITH A THICK CLOTH AND TURN IT SLOWLY COUNTER-CLOCKWISE TO THE FIRST STOP. AFTER THE PRESSURE HAS BEEN COMPLETELY RELEASED, PRESS DOWNWARD AND FINISH REMOVING CAP. FAILURE TO FOLLOW THESE INSTRUCTIONS COULD RESULT IN DAMAGE TO THE COOLING SYSTEM OR ENGINE AND/OR PERSONAL INJURY.

CAUTION: Do not add coolant to an engine that has become overheated until the engine cools. Adding coolant to an extremely hot engine can result in a cracked block or cylinder head.

1. Allow the engine to cool down to 40°C (110°F).
2. Turn the radiator expansion/degas tank filler cap through 90° in a counter-clockwise direction. Pause to allow any pressure to drop, then turn cap fully counterclockwise and remove it.
3. The quantity of coolant in the expansion/degas tank is a direct indication of the coolant level in the complete system. The acceptable level of coolant in the expansion/degas tank is shown by the level indicators moulded into the tank wall. Top up as necessary with a mixture of plain water and antifreeze -- Refer to "Cooling System" on page 28 for information on mixing antifreeze solutions.

NOTE: It is essential that only the correct type of antifreeze is used -- Refer to "Cooling System" on page 28.

4. Replace the filter cap and turn down tightly.

Renew Air Cleaner Element

Your air cleaner filters air entering the engine induction system and acts as a silencer and a flame arrester. Air that contains dirt and grit produces an abrasive fuel mixture, and can cause severe damage to the cylinder walls and piston rings. Damage to the cylinder walls and piston rings will cause high oil consumption and short engine life. A restricted or dirty air cleaner will also cause a rich fuel mixture. Thus, it is extremely important that the air cleaner be serviced at recommended intervals.

CAUTION: Service the air cleaner more frequently under severe dust conditions to prevent engine damage.

1. Release the air cleaner lid retaining hardware.
2. Lift the air cleaner lid clear of the air cleaner body, then remove the air cleaner element and discard it.
3. Wipe the inside of the air cleaner body and lid clean, using a lint-free rag.
4. Insert the new element, ensuring that it fits properly and install air cleaner lid.

Renew PCV Valve

The PCV valve is located in the oil separator on the left side of engine. Remove and replace as follows:

1. Gently pry cap off of two tabs.
2. Remove hose from PCV valve.
3. Remove PCV valve from oil separator.
4. Reverse procedure to install.

NOTE: A small amount of oil can be used to aid in installation.

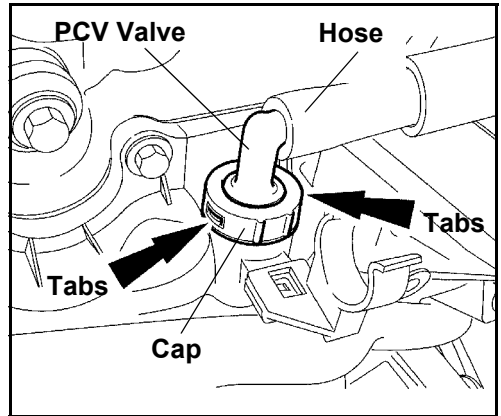

GENERAL MAINTENANCE INFORMATION

The following section outlines some aspects of general maintenance which will be of value to the operator.

Cooling System

To obtain maximum engine service life, its operating temperature must be maintained by an efficient cooling system.

CAUTION: Under no circumstances should the engine be started without liquid in the cooling system. This may cause permanent damage to the engine.

CAUTION: The use of straight water as a coolant will cause permanent damage to the engine.

Inspect the exterior of the radiator for obstructions, remove all bugs, dirt or foreign material with a soft brush or cloth.

Use care to avoid damaging the fins. If available, use low pressure compressed air or a stream of water in the opposite direction to normal airflow. Check all hoses and connections for leaks. If any of the hoses are cracked, frayed, or feel spongy, they should be replaced.

CAUTION: Never use a cold coolant mixture to top-up the radiator or degas tank of a hot engine if the coolant level is very low; this could cause serious engine damage.

The radiator or degas tank is equipped with a pressure cap. It is dangerous to remove this when the system is very hot.



WARNING: NEVER REMOVE THE PRESSURE RELIEF CAP WHILE THE ENGINE IS OPERATING OR WHEN THE COOLING SYSTEM IS HOT. MAY CAUSE PERSONAL INJURY OR DAMAGE TO COOLING SYSTEM OR ENGINE. TO REDUCE THE RISK OF HAVING SCALDING HOT COOLANT OR STEAM BLOW OUT OF THE DEGAS BOTTLE WHEN REMOVING THE PRESSURE RELIEF CAP, WAIT UNTIL THE ENGINE HAS COOLED DOWN TO AT LEAST 40°C (110°F).

1. Wrap a thick cloth around the pressure relief cap and turn it slowly one-half turn counterclockwise. Stepping back while the pressure is released from the cooling system.
2. When you are sure all the pressure has been released, (still with a cloth) turn counterclockwise and remove the pressure relief cap.

In territories where freezing conditions may occur, the coolant should consist of a mixture of 50% plain water and 50% Motorcraft Premium Gold coolant, or equivalent. This antifreeze contains additional corrosion inhibitors designed to provide lasting protection for the engine.

Motorcraft Premium Gold engine coolant, or equivalent, has long life characteristics and if the concentration is kept to a maximum of 50% it will provide adequate frost protection and inhibiting for the life of the engine.

NOTE: If a major component of the cooling system is renewed such as the radiator, water pump etc., the system should be flushed and re-filled with a 50% solution of Motorcraft Premium Gold engine coolant, or equivalent, and clean water.

In territories where the ambient temperature is such that no protection against freezing is required, it is recommended that a 25% concentration of Motorcraft Premium Gold engine coolant, or equivalent, is used. This will protect water pumps, core plugs, thermostat housings and radiators against corrosion for the life of the engine and raise boiling point when used at this concentration. See previous Note on renewing cooling system components.

The antifreeze concentration in a cooling system can be determined by using a suitable hydrometer.

- A reading of 1080 represents a 50% antifreeze concentration.
- A reading of 1040 represents a 25% antifreeze concentration.
- A reading of 1000 represents plain water.

CAUTION: Do not add or mix an orange-colored extended life coolant, such as Motorcraft Specialty Orange engine coolant with factory filled coolant WSS-M97B44-D. Mixing Motorcraft Specialty Orange engine coolant or any orange colored extended life product, with factory filled coolant, can result in degraded corrosion protection.



WARNING: ANTIFREEZE CONTAINS MONO ETHYLENE GLYCOL AND OTHER CONSTITUENTS WHICH ARE TOXIC IF TAKEN INTERNALLY AND CAN BE ABSORBED IN TOXIC AMOUNTS ON REPEATED OR PROLONGED SKIN CONTACT. PERSONS USING ANTIFREEZE ARE RECOMMENDED TO ADHERE TO THE FOLLOWING PRECAUTIONS:

- **ANTIFREEZE MUST NEVER BE TAKEN INTERNALLY. IF ANTIFREEZE IS SWALLOWED ACCIDENTALLY, MEDICAL ADVICE SHOULD BE SOUGHT IMMEDIATELY.**
- **PRECAUTIONS SHOULD BE TAKEN TO AVOID SKIN CONTACT WITH ANTIFREEZE. IN THE EVENT OF ACCIDENTAL SPILLAGE ONTO THE SKIN, ANTIFREEZE SHOULD BE WASHED OFF AS SOON AS PRACTICABLE. IF CLOTHING IS SPLASHED WITH ANTIFREEZE, IT SHOULD BE REMOVED AND WASHED BEFORE BEING WORN AGAIN, TO AVOID PROLONGED SKIN CONTACT.**
- **FOR REGULAR AND FREQUENT HANDLING OF ANTIFREEZE, PROTECTIVE CLOTHING (PLASTIC OR RUBBER GLOVES, BOOTS AND IMPERVIOUS OVERALLS OR APRONS) MUST BE USED TO MINIMIZE SKIN CONTACT.**

Draining, Flushing and Filling the Cooling System



WARNING: NEVER REMOVE THE PRESSURE RELIEF CAP WHILE THE ENGINE IS OPERATING OR WHEN THE COOLING SYSTEM IS HOT. MAY CAUSE PERSONAL INJURY OR DAMAGE TO COOLING SYSTEM OR ENGINE. TO REDUCE THE RISK OF HAVING SCALDING HOT COOLANT OR STEAM BLOW OUT OF THE DEGAS BOTTLE WHEN REMOVING THE PRESSURE RELIEF CAP, WAIT UNTIL THE ENGINE HAS COOLED DOWN TO AT LEAST 40°C (110°F).

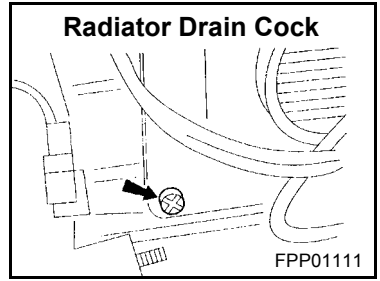

1. Wrap a thick cloth around the pressure relief cap and turn it slowly one-half turn counterclockwise. Stepping back while the pressure is released from the cooling system.
2. When you are sure all the pressure has been released, (still with a cloth) turn counterclockwise and remove the pressure relief cap.
3. Remove the radiator expansion/ degas tank filler cap, then open the radiator drain cock, where fitted, or detach the bottom radiator hose.
4. Flush the system with water using a hose until clean water emerges and allow all water to drain out. Close the drain cock (or replace the bottom radiator hose). Recover all old antifreeze and dispose of properly. Contact your local municipal government for the proper disposal.
5. Fill the system with the correct coolant mixture via the expansion/degas tank filler neck. Fill the system slowly, to avoid air locks, up to the 'maximum' mark on the degas tank.
6. Run engine and check hose connections for leaks. Check, and, if necessary, top up the coolant in the radiator or degas tank.

Engine Lubrication System

The lubrication system should be maintained regularly -- Refer to "RECOMMENDED MAINTENANCE SCHEDULES" on page 21, with the correct grade of lubricant as specified in the maintenance summary -- Refer to "Recommended Lubricants" on page 22. The system is of the force feed type, the lubricating oil being circulated to the engine bearings under pressure by an oil pump driven from the camshaft drive chain belt.

The dipstick provides some guide to the condition of the oil. An additive type of oil keeps soot in suspension, and even a small amount of soot causes the oil to darken rapidly.

However, if the dipstick is found to be heavily coated with sludge, then obviously the oil should be changed.

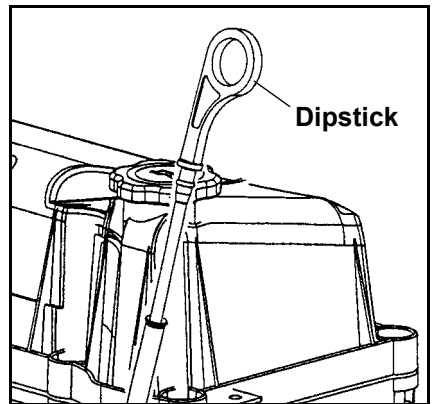

Electrical System

A NEGATIVE EARTH (NEGATIVE GROUND) SYSTEM IS USED.

GCP - Power Distribution Box

Part of -5250010- Wiring Harness

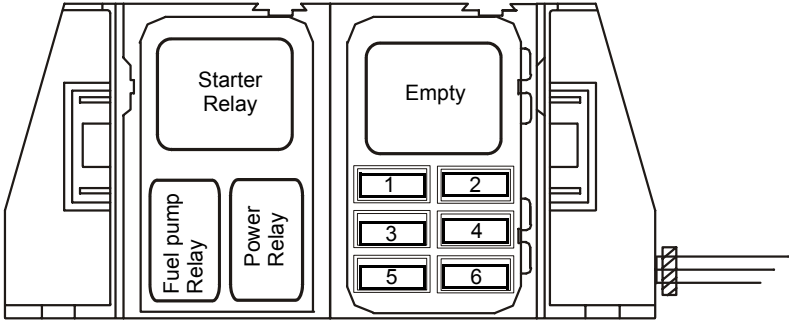

Fuse	Amps	Circuits protected
1	10	Battery Voltage to EPR
2	5	Ignition Voltage to GCP and Relays
3	10	Battery Voltage to GCP
4	15	Fuel pump
5	15	Battery Voltage out of Power Relay
6	-	Not used

Generator

This is mounted on a bracket at the front of the engine and is driven from the crankshaft by a serpentine belt.

The charging rate is adjusted automatically by the built-in regulator to provide sufficient electric current to keep the battery fully charged under normal operating conditions.

The generator requires no lubrication or maintenance.



WARNING: IT IS ESSENTIAL THAT THE WIRING CONNECTIONS TO THE GENERATOR ARE NOT REMOVED WHILE THE ENGINE IS RUNNING, AS THIS WILL RESULT IN DAMAGE TO THE REGULATOR OR PERSONAL INJURY.

Storage

NOTE: It is highly recommended that a fuel stabilizer, Ford Part Number E8AZ-19C544-A or an equivalent additive be used for any length of storage. It is imperative in any application where the fuel will not be consumed within thirty days. Ford Fuel stabilizer comes in an 8 fl.oz. bottle for consumer use and should be available through all EDI Distributors. The correct ratio is 2 oz. Stabilizer to 5 gallons of gasoline. Without the use of an additive, the unused fuel in your fuel tank can and will go sour in a very short period of time, causing varnish and contaminants to form. This causes problems in fuel delivery by clogging fuel injectors.

Storage - One Month

- Add fuel stabilizer (see previous note).
- While the engine is running, treat upper cylinders by spraying engine fogging agent (from your local aftermarket supplier) into the air intake for about two minutes. Open throttle for short burst of speed, shut off engine and allow it to come to a stop while continuing to spray into air intake.
- Leave spark plugs in holes or seal spark plug holes with suitable threaded metal plugs and cover all openings into engine with dust-proof caps or shields (suitable non-hygroscopic material).
- If engine is less transmission, spray flywheel and ring gear with mixture of one part recommended engine oil, and one part Stoddard Solvent or equivalent.
- Check coolant protection. Store indoors in dry area.

Storage - Indefinite Period

- Add fuel stabilizer (see previous note).
- Drain crankcase completely and refill with recommended engine oil, (SAE 10) or equivalent.
- Run engine until completely out of fuel. Gasoline only: Restart and run on unleaded gasoline, mixed with stabilizer, for at least 10 minutes. While engine is still running and at completion of above run, treat upper cylinders by spraying fogging agent into the air intake for about two minutes. Open throttle for short burst of speed, shut off engine and allow it to come to a stop while continuing to spray into air intake.
- Check coolant protection
- Disconnect and remove battery.
- Clean exterior surface of engine.
- Leave spark plugs in holes or seal spark plug holes with suitable threaded metal plugs.
- Seal all openings in engine and accessories with non-hygroscopic material. Mask off all areas to be used for electrical contacts.
- Make sure all surfaces are dry, then spray all taped openings, all engine accessories including ignition wiring, and all exterior surfaces of engine with Insulation Compound.
- If engines are equipped with automotive type clutch, block clutch in slightly disengaged position so that lining and pressure plates are not in contact.

ENGINE SYSTEM CHECK

GCP System Check

NOTE: Items listed in the possible cause column generally do not set a diagnostic trouble code (DTC) or illuminate the MIL light.

NOTE: EDI engines are used in many different applications and equipment. When performing any system diagnosis be aware of any OEM inputs or equipment monitoring devices that may have an effect on the engine's performance or any of the engine's operating systems.

Engine Performance - No Load

SYMPTOM	POSSIBLE CAUSE
Engine Runs Briefly and Shuts Down	<ul style="list-style-type: none">• Loss of Spark• Frozen Fuel Regulator (Dry Fuel)• Low Fuel Pressure• Air Inlet Restriction• Wiring Failure• IPM/EPM Failure
Engine Cranks But No Start	<ul style="list-style-type: none">• Faulty OEM Drivers Safety Shut-Off Seat Switch• Coil Power Loss• IPM/EPM Ground Loss• IPM/EPM Power Loss• Severe Vacuum Leak (Dry Fuel)• Air Inlet Restriction• Air Inlet Leak (Dry Fuel)• Fuel Lock-Off Inoperative (Dry Fuel)• Wiring Failure• Low Fuel Pressure• Ancillary Components Binding
Engine Runs Poorly	<ul style="list-style-type: none">• High Fuel Pressure• Low Fuel Pressure• Contaminated Fuel• Incorrect Fuel Select Table Selected• Wrong IPM/EPM Installed• Actuator Air Blockage• Map Sensor Leak• Fuel Contaminated• Noise Suppression Capacitor Failure• Improper PCV Routing• Valve Timing• Low Cylinder Compression
Engine Cranks Slowly	<ul style="list-style-type: none">• Excessive Engine Load (Hydraulic Pump Failing, Binding Ancillary Drive Components)• Low Battery Voltage• Incorrect Battery Specifications• Incorrect Battery Cable Size• Starter Relay• Starter Failure (Excessive Drain)

SYMPTOM	POSSIBLE CAUSE
Engine Does Not Crank	<ul style="list-style-type: none"> • Dead Battery • Ground Loss • Ancillary Components Binding or Seized • OEM Shutdown - Oil Level Safety • Starter Lockout Relay Failure • Ignition Switch Failure • Bad Starter • Crank Control Wire Failure • Loose Connection or Corrosion

Engine Performance - While Under Load

SYMPTOM	POSSIBLE CAUSE
Engine Stalls/Quits	<ul style="list-style-type: none"> • Faulty OEM Drivers Safety Shut-off Seat Switch • Low Battery Voltage • Low Fuel Pressure • OEM Safety Shutdowns • Bad MAP Sensor • Air Restriction • Coil Failure • Fuel Mixer Binding (Dry Fuel)
Runs Rough	<ul style="list-style-type: none"> • Ground Loss • Misrouted Spark Plug Wires • Fuel System Failure • Vacuum Leak • Wiring Failure • Low Fuel Pressure • Spark Plugs Fouled • Incorrect Valve Timing
Misses	<ul style="list-style-type: none"> • Fuel System Failure • Misrouted Spark Plug Wires • Spark Plug Gap Too High • Spark Plugs Fouled • Cracked Spark Plug Insulator • Incorrect Valve Timing • Compression Loss
Hesitation/Stumble	<ul style="list-style-type: none"> • Low Fuel Pressure • Spark Plugs Fouled • MAP Sensor Vacuum Signal Loss
Surge	<ul style="list-style-type: none"> • Low Fuel Pressure • Map Sensor Failure • Application or Ancillary System Momentarily Binding During Load or Unload
Backfires	<ul style="list-style-type: none"> • Faulty OEM Drivers Safety Shut-off Seat Switch • Fouled Spark Plugs • Spark Plug Wire Broke • IPM/EPM Momentary Ground Loss • Excess Lean Condition • Fuel Lock-Off Leaking (Dry Fuel) • Intake Manifold Leak • Bad Intake Valve

SYMPTOM	POSSIBLE CAUSE
Lack of Power	<ul style="list-style-type: none"> • Ancillary Components Binding • Intake Air Restriction • Crossed Spark Plug Wires • Spark Plugs Fouled • Fuel System Failure • Low Fuel Pressure • Low Cylinder Compression
Spark Knock	<ul style="list-style-type: none"> • Poor Quality or Contaminated Fuel • Carbon Build-up • Wrong Spark Plugs (Too High Heat Range) • Fuel Delivery System • PCV System • Fuel Selection Timing • Cylinder Hot Spots

Engine Concerns

SYMPTOM	POSSIBLE CAUSE
Oil System Concerns - High Oil Consumption	<ul style="list-style-type: none"> • Positive Crankcase Ventilation (PCV) System • Oil Viscosity • External Leaks • Improper Oil Dipstick • Valve Seals • Cylinder Wall Taper Excessive • Worn Piston Rings
Cooling System Concerns	<ul style="list-style-type: none"> • Trapped Air • Worn Drive Belt • Worn Water Pump • Stuck Thermostat • Plugged Radiator (Internal & External) • Dry Fuel System Running Rich
Exhaust System Concerns (visible smoke) - Black Smoke - Blue Smoke	<ul style="list-style-type: none"> • Ignition System • Fuel Delivery System • Sticking Fuel Injector • High Fuel Pressure • PCV System • Worn Piston Rings • Worn Valve Guides
Fuel System Concerns	<ul style="list-style-type: none"> • Leaky Lines • Contaminated Fuel • Excessive Alcohol in Fuel • Incorrect Octane Rating
Engine Noise	<ul style="list-style-type: none"> • Low Oil Pressure • Oil Filter Restriction

SPECIFICATIONS

General Specifications	
Engine Type:	I-4 cylinder 4 stroke spark ignition.
Liter/CID:	2.3 / 140
Bore: mm (inch)	87.5 mm (3.44 in.)
Stroke: mm (inch)	94 mm (3.70 in.)
Number of cylinders:	4
Compression Ratio:	9.7:1

Fuel System	
LPG Type: Fuel Specification:	Liquefied Petroleum Gas Fumigation EN589 (European) HD5 (USA)
NG Type: Fuel Specification:	Natural Gas Fumigation 38.7 MJ/m ³ (UK) 39.0 MJ/m ³ (USA)
Gasoline Fuel Specification:	Gasoline (petrol) Unleaded 87 or 89 Octane (Gasoline blends not to exceed 10% Ethanol by volume Octane Index of 87 or 89).
Fuel Pump Pressure Normal:	75 psi

Lubrication System	
Max. Oil Pressure:	Hot@2000 rpm: 200-268 kPa (29-39 psi)
Oil Type:	Super Premium SAE5W20 WSS M2C930-A
Service Oil fill capacity (including filter):	4.0 qt. (3.78 L) = 3.5 qt. Pan + 0.5 qt. filter
Oil filter	Ford Service Part Number:1S7G 6714 DA Motorcraft: FL 910

Cooling System

Thermostat:	Type: Wax element Commences opening: 88.9°C Fully open: 100°C
Coolant	50% Motorcraft Premium Gold engine coolant plus 50% clear water Ford Specification: WSS-M97B51-A1

Drive Belts

Front end accessory drive belt & tension	Serpentine belt with automatic tension control.
--	---

Electrical System

Polarity:	Negative to earth (ground)
Battery Capacity:	750 CCA / 140 RC
Generator Drive Belt Tension (8K Poly Belt):	Tension is within specification if the tensioner is within the indicator markings
Generator Output	95 Amp

Ignition System

Spark Plug (see Note)	Type: AGSF32YPC Gap: 1.25 - 1.35 mm (0.049 - 0.053 in.)
Firing Order	1-3-4-2

TIGHTENING TORQUES

ITEM	Nm	FT. LB.	LB. IN.
Oil Pan Drain Plug	28	21	
Spark Plugs	15	11	
Oil Filter			25-151.6

CONVERSION TABLE

TO CONVERT FROM TO	TO FROM	MULTIPLY BY DIVIDE BY
Distance		
inches	mm	25.4
inches	m	0.0254
feet	mm	304.8
feet	m	0.3048
yards	m	0.9144
mile	km	1.609
Area		
in ²	mm ²	645.16
ft. ²	m ²	0.0929
yds ²	m ²	0.8361
Volume		
in ³	cm ³	16.3871
in ³	1 liter	0.016387
pint (us)	1 liter	0.47318
pint (uk)	1 liter	0.56826
quart (us)	1 liter	0.94635
gallon (us)	1 liter	3.7854
gallon (uk)	1 liter	4.5461
ft. ³	1 liter	28.3168
ft. ³	m ³	0.02832
Mass		
oz.	g	28.3495
lb.	kg	0.45359
ton (US)	tonne	0.90718
ton (UK)	tonne	1.01605
FORCE		
lbf	N	4.44822
PRESSURE & STRESS		
kpa	Bar	0.01
lbf/in ² (psi)	N/m ²	6894.76
lbf/in ² (psi)	Bar	0.0689
lbf/in ² (psi)	N/mm ²	0.00689
lbf/m ² (psi)	mmHg	51.715
"H ₂ O	mmH ₂ O	25.4
"Hg	mmHG	25.4
ton (US)/in ²	N/mm ²	13.7894
ton (UK)/in ²	N/mm ²	15.4443
VELOCITY		
ft./sec.	m/s	0.3048
ft./sec.	km/h	1.09728
miles/h	m/s	0.44694
miles/h	km/h	1.609
ACCELERATION		
ft./sec ²	m/s ²	0.3048
ENERGY		
Btu	J	1055.06
Kcal	J	4186.8
HP.h	kW.h	0.7457
PS.h	kW.h	0.7355
TORQUE		
lb./ft.	Nm	1.35582
POWER		
HP	kW	0.7457
PS	kW	0.7355
HP	PS	1.01387
SPECIFIC FUEL CONSUMPTION		
lb./hp.h	g/kW.h	608.277

EDI DISTRIBUTORS

North America - Canada

ONTARIO, QUEBEC, MONITOBA	M-K Power Products Corp.	5641 McAdam Road Mississauga, Ontario, Canada, L4Z-1N9	905-890-5323
ALBERTA, SASKATCHEWAN	Industrial Engines, Ltd.	14355 120th Avenue Edmonton, Alberta Canada, T5L 2R8	780-484-6213

North America - United States

ALABAMA	M&I Ford	30762 State Highway 181 Daphne, AL 36526	800-633-1834
CALIFORNIA	Powertech Engines Inc.	2933 E. Hamilton Avenue Fresno, CA 93721	559-264-1776
FLORIDA	Engine Distributors, Inc.	259 Ellis Rd South Jacksonville, FL 32254	800-342-3576
	Engine Distributors, Inc.	2917 S. W. Second Ave. Fort Lauderdale, FL 33315	800-257-6605
MICHIGAN	EngineCenter, Inc.	2351 Hilton Road Ferndale, MI 48220	800-726-8870
MISSOURI	C K Power Products	1100 Research Blvd. St. Louis, MO 63132	314-868-8620
NEBRASKA	Anderson Industrial Engines Co.	5532 Center Street Omaha, NE 68106	402-558-8700
NEW JERSEY	Engine Distributors, Inc.	400 University Court Blackwood, NJ 08012	800-220-2700
NORTH CAROLINA	Engine Distributors, Inc.	303 Interstate Drive Archdale, NC 27263 3148	800-220-7080
OHIO	Graham Ford Inc.	707 W. Broad St. Columbus, OH 43222	614-464-6000
	North Coast Ford Industrial	11885 Bellaire Road Cleveland, OH 44135	216-251-5800
PENNSYLVANIA	Pitt Auto Electric	1241 Freedom Road Cranberry Twp., PA 16066	724-778-8200
WASHINGTON	Pacific Torque	18060 Des Moines Memorial Drive, Burien, WA 98148	206-241-8300



EDI Worldwide Service
Engine Distributors Inc
400 University Court
Blackwood NJ 08012

Service/Warranty

1-800-220-2700

1-856-228-7298

1-856-228-5657(fax parts & service)

1-856-228-5531(fax sales)



EDI Worldwide Service
Engine Distributors Inc
400 University Court
Blackwood NJ 08012
Service/Warranty
1-800-220-2700
1-856-228-7298
1-856-228-5657(fax parts & service)
1-856-228-5531(fax sales)