



Installation

**'F7 @)' \$\$**

IMT MANUAL # JJJ€ ì Fî

IOWA MOLD TOOLING CO., INC.

PO Box 189

Garner, IA 50438

Tel: 641-923-3711 FAX: 641-923-2424

Website: <http://www.imt.com>

Copyright © 2014 Iowa Mold Tooling Co., Inc. All rights reserved.

No part of this publication may be reproduced, stored in a retrieval system, or transmitted in any form or by any means, electronic, mechanical, photocopying, recording or otherwise without the prior written permission of Iowa Mold Tooling Co., Inc.

Iowa Mold Tooling Co., Inc. is an Oshkosh Corporation company.



## General Installation Instructions

This chapter provides instructions for how to handle the RCL 5300 Safety System, when the loader is to be fitted on a vehicle, during service overhauls and in case of connection of any optional extras.

To obtain the maximum operational safety possible, it is important to follow the installation instructions thoroughly.

### RCL 5300 controller

The RCL 5300, 5301 and 5303 controllers are hinged to the box, which makes it easy to access the input and output terminals. The individual wires are mounted in detachable multi-plugs on the controller's printed circuit board.

At the bottom of the box, is fitted a plate with cable lead-ins as well as a membrane valve, which ventilates the box. The valve prevents water penetration, but ensures that any condensation water can pass out of the box.

Because all controllers in the safety system are very tight (IP66), i.e. water-tight and dust-tight, the input and output terminals are not greased.

The controllers have "floating" in- and outlets. I.e. one particular in-/outlet is not dedicated to one particular type of sensor, but it can be configured to several types of sensors in the safety system.

There are special requirements to the power supply for the electronic safety system:

- The RCL 5300 controller (as well as radio remote control, if any) **must** have its own separate power supply to the battery of the vehicle.
- All other power-requiring equipment such as oil coolers, spotlights **must** have its own separate power supply to the battery.

This separation of the power supplies is necessary to avoid both voltage drops and voltage peaks getting into the safety system.

The combination of separate power supply and the built-in protection of the electronic components in the controllers ensure maximum operational safety in the safety system.

When connecting the loader's electric system to the power supply of the vehicle, the current instructions from the supplier must be respected.



**Please note:**

The guarantee on the components in the electronic system is void; if it is determined that power consuming equipment has been connected to the RCL 5300 or one of the other controllers.

The power supply to the controllers is being monitored. The highest voltage peak as well as the number of peaks can be read from the black box-function in the RCL 5300.

## External sensors and valves

The electric plugs for the following sensors and valves:

- Pressure transducers
- Spool sensors
- Proximity switches
- Dump valve
- Change-over valve, loader/stabilizers
- Change-over valve, Fly-Jib/extra functions

must be filled inside with water repellent lubricant of the Loctite 8104 type (HMF part no. 19151, 75 ml) to prevent water encroachment and moisture penetration.

The rubber sealing must be fitted correctly and water repellent lubricant must be applied on all surfaces between the plug, the seal and the sensor/valve.

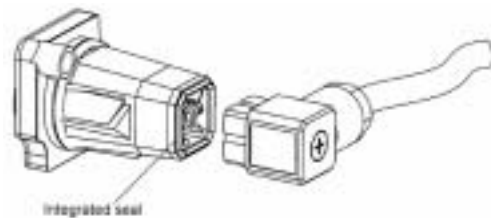
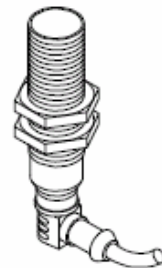
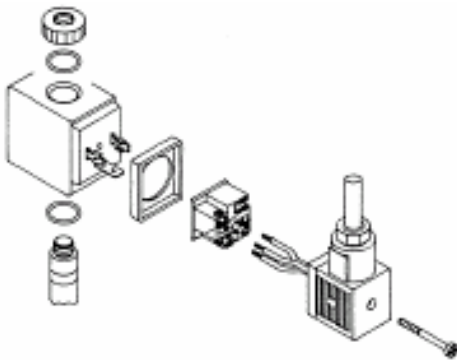
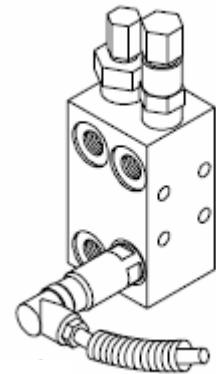

## Important advice when working with the electronic safety system

Do not connect electric components (spotlights, solenoid valves or others) to the RCL 5300 controller or any of the other controllers.

Do not either connect electric components to the power supply cable for the controllers.

If electric components are to be fitted on the loader or another place on the vehicle, these components must be connected to the battery of the vehicle by means of a separate power supply cable.

Alternatively, supplementary electric components can be connected to the I/O-box (if fitted), provided that the electric power lies within the specifications of the I/O-box.

If loaders are mounted in applications where it is not possible to connect the safety system to a battery, it may be necessary to use an electric transformer (e.g. 230 V  $\approx$  / 24 V  $\Rightarrow$ ).

The transformer has to be dimensioned with regards to power consumption and smoothed direct voltage in each single case depending on the equipment fitted.

Remove the cable for the power supply, if you are to weld on the vehicle. Otherwise there is a risk of the electronic safety system being overloaded and in worst case damaged.

Remove the cable for the power supply, if the battery of the vehicle is discharged, and connect a "boost starter" to start the engine. Any kind of too high charging voltage (power supply) or voltage peaks entail the risk of overloading and in the worst case damaging the electronic safety system.

Be careful if the loader is to be washed in connection with service overhauls. Avoid spraying on water and never use high-pressure rinsing for cleaning the electronic components. Also be careful not using noxious chemicals and detergents.

# Connection to power supply

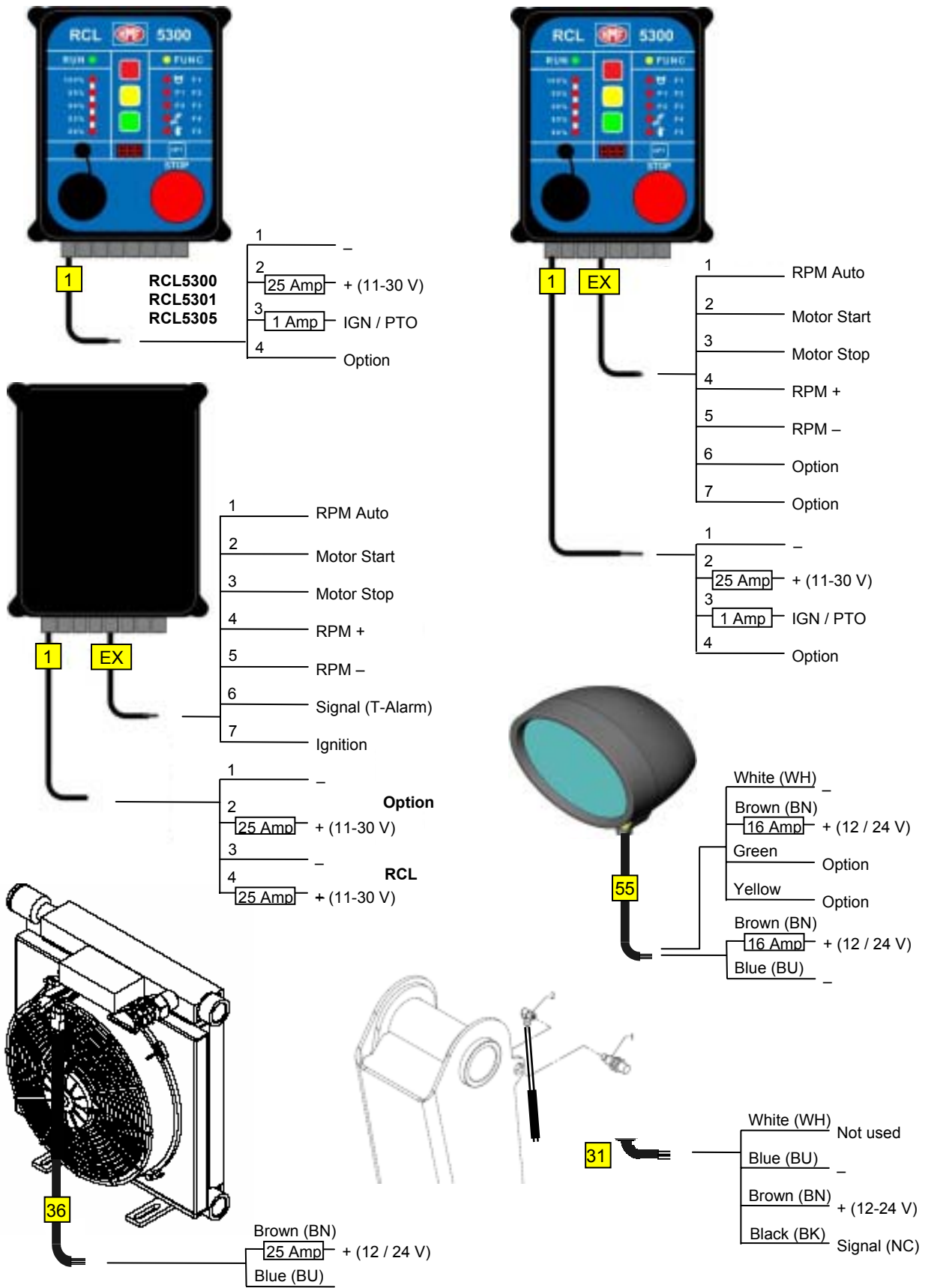

## Survey of terminals, RCL 5300

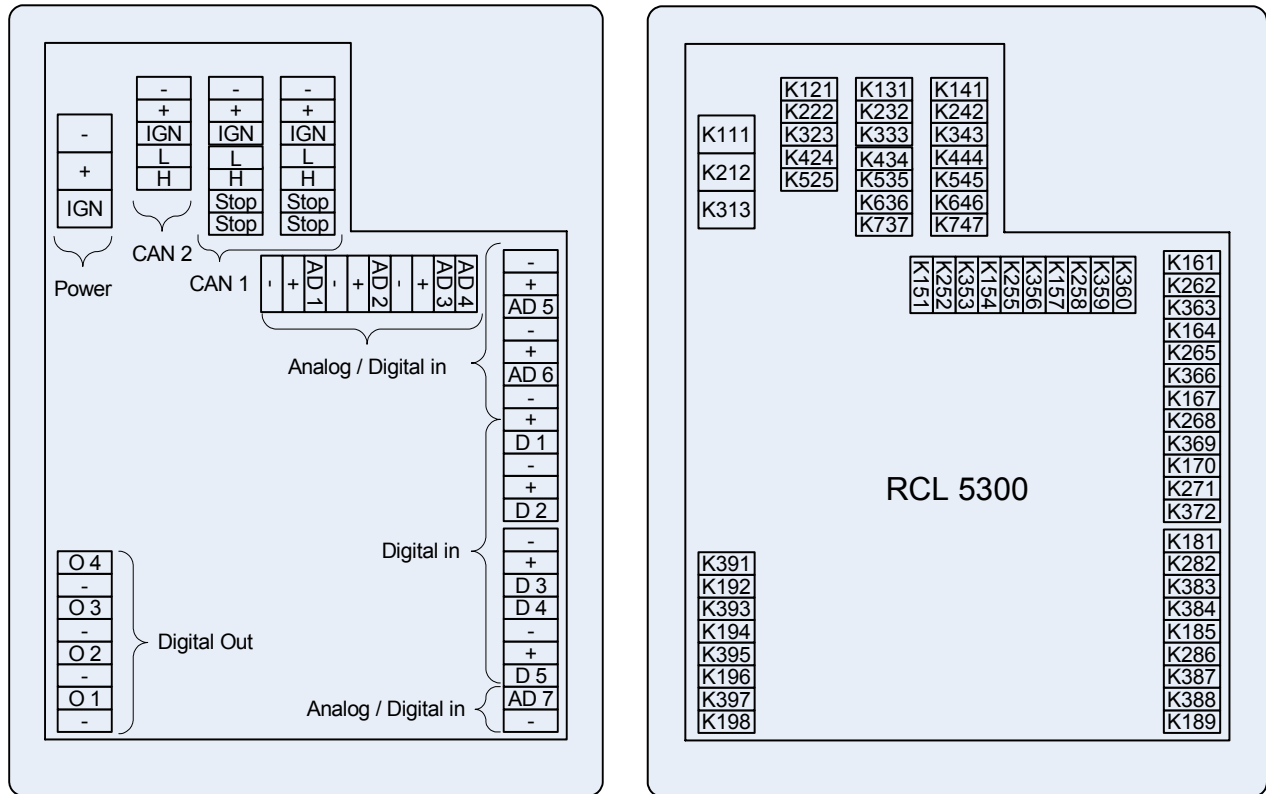

Terminal	Signal	Explanation
K1xx	Supply ÷	The first figure in the terminal number indicates the signal type.
K2xx	Supply +	
K3xx	Signal	
K4xx	CAN Low	
K5xx	CAN High	
K6xx	Stop (stop button)	
K7xx	Stop (stop button)	
Kx1x	Power	The second figure in the terminal number indicates the number of the plug. As to plugs with more than 9 terminals, continue with the next number in the sequence of numbers.
Kx2x	CAN Bus 2	
Kx3x	CAN Bus 1	
Kx4x	CAN Bus 1	
Kxx1	Number	The third figure indicates the terminal number. As to plugs with more than 9 terminals, the third figure is increased by the next figure in the sequence of numbers (K170, K271, K372).



## Survey of terminals, RCL 5301

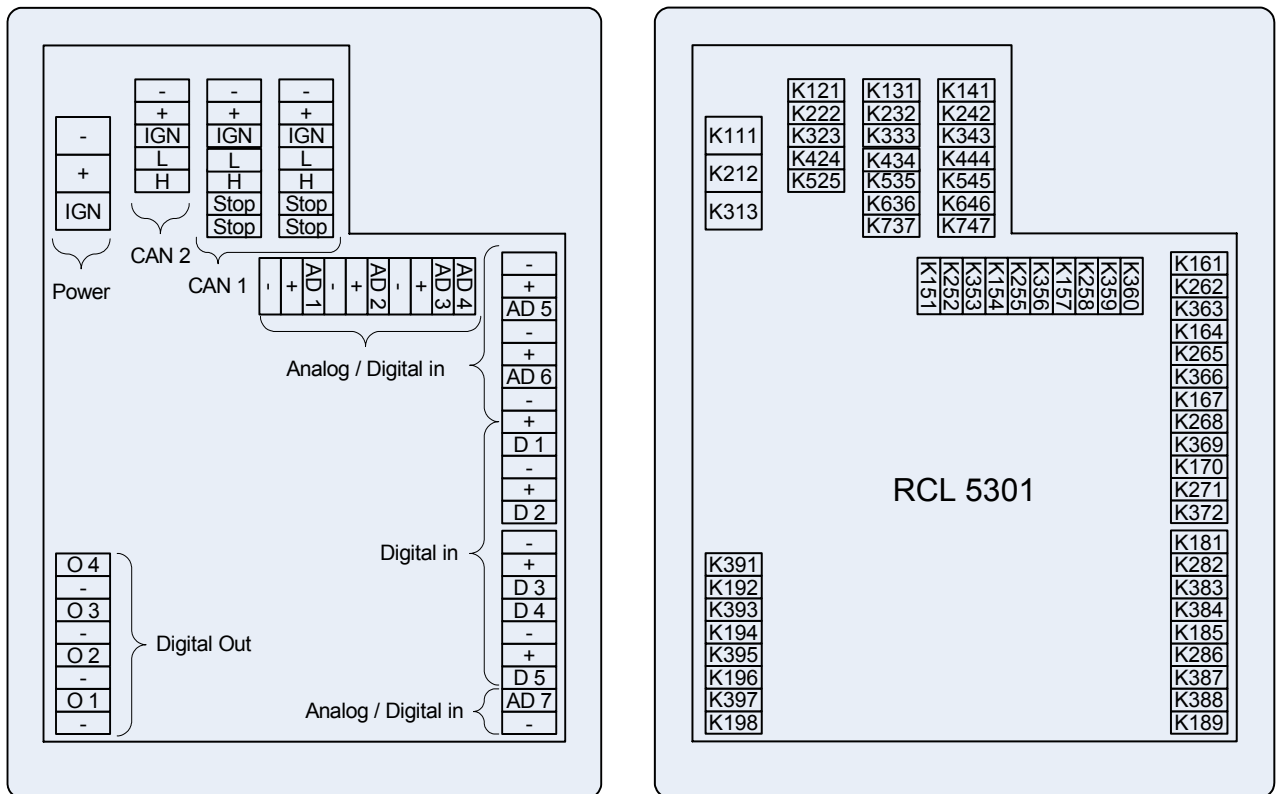

Terminal	Signal	Explanation
K1xx	Supply ÷	The first figure in the terminal number indicates the signal type.
K2xx	Supply +	
K3xx	Signal	
K4xx	CAN Low	
K5xx	CAN High	
K6xx	Stop (stop button)	
K7xx	Stop (stop button)	
Kx1x	Power	The second figure in the terminal number indicates the number of the plug. As to plugs with more than 9 terminals, continue with the next number in the sequence of numbers.
Kx2x	CAN Bus 2	
Kx3x	CAN Bus 1	
Kx4x	CAN Bus 1	
Kxx1	Number	The third figure indicates the terminal number. As to plugs with more than 9 terminals, the third figure is increased by the next figure in the sequence of numbers (K170, K271, K372).



## Survey of terminals, ECT 5320

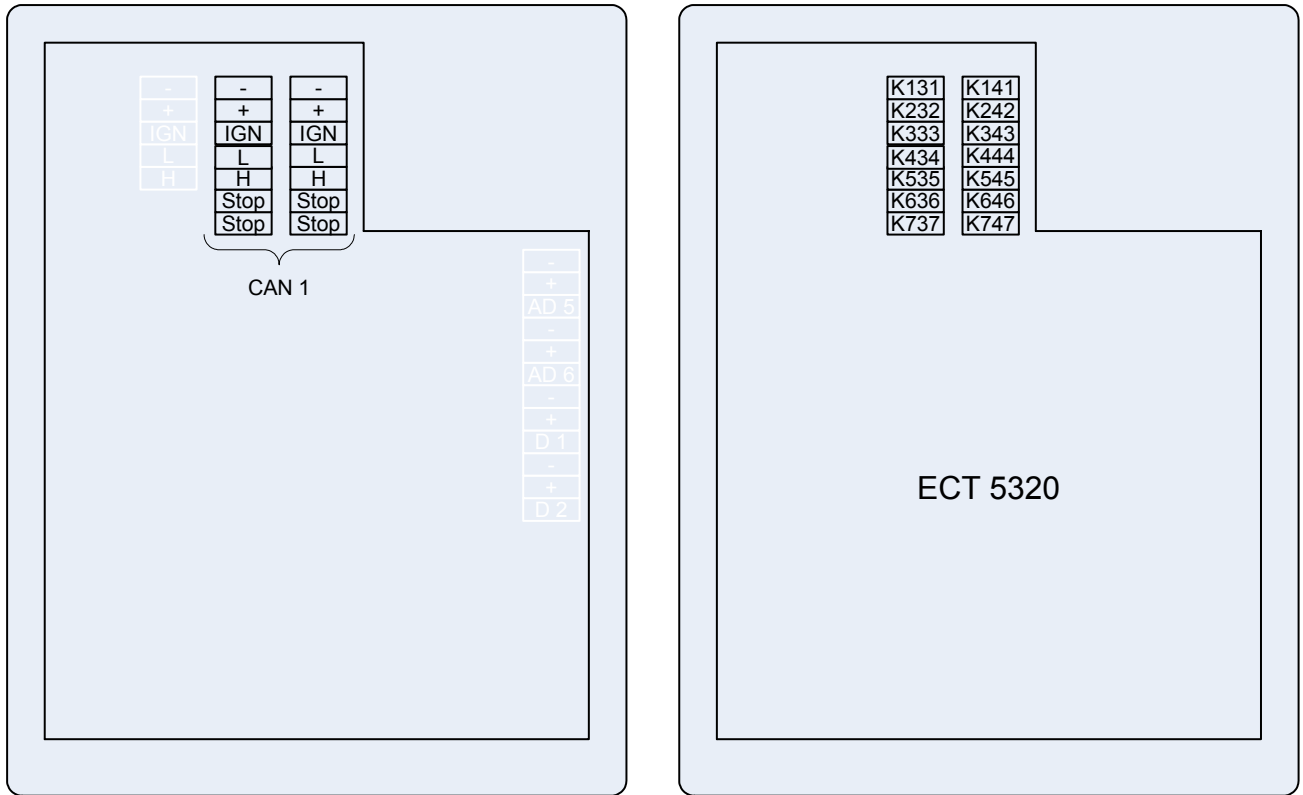

Terminal	Signal	Explanation
K1xx	Supply ÷	The first figure in the terminal number indicates the signal type.
K2xx	Supply +	
K3xx	Signal	
K4xx	CAN Low	
K5xx	CAN High	
K6xx	Stop (stop button)	
K7xx	Stop (stop button)	
Kx3x	CAN Bus 1	The second figure in the terminal number indicates the number of the plug.
Kx4x	CAN Bus 1	
Kxx1	Number	The third figure indicates the terminal number.

□ Indicates a terminal, which is not connected to the printed circuit board.

## Survey of terminals, FJC 5330

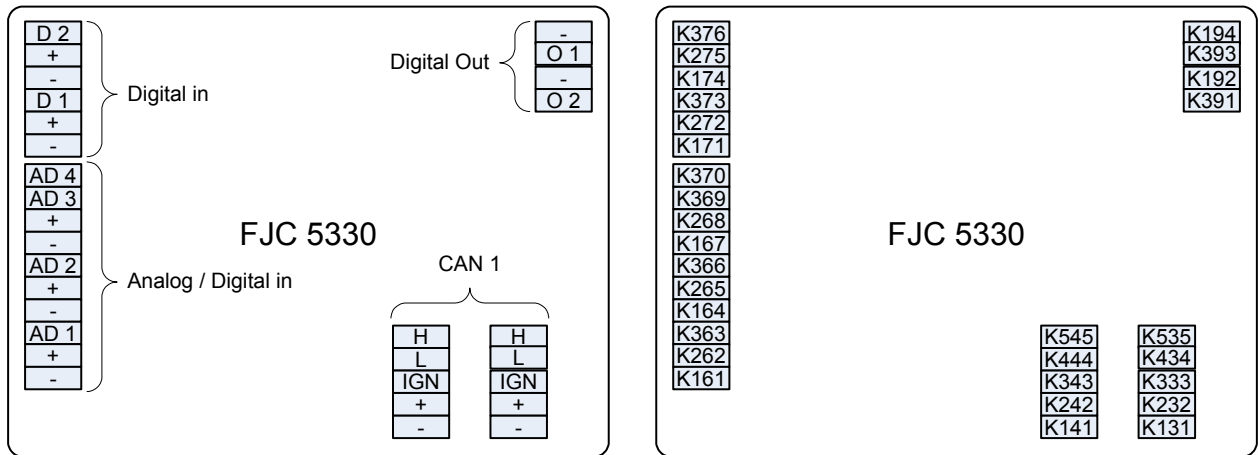

Terminal	Signal	Explanation
K1xx	Supply ÷	The first figure in the terminal number indicates the signal type.
K2xx	Supply +	
K3xx	Ignition	
K4xx	CAN Low	
K5xx	CAN High	
Kx1x	Power	The second figure in the terminal number indicates the number of the plug.
Kxx1	Number	The third figure indicates the terminal number.

## Survey of terminals, WIC 5333

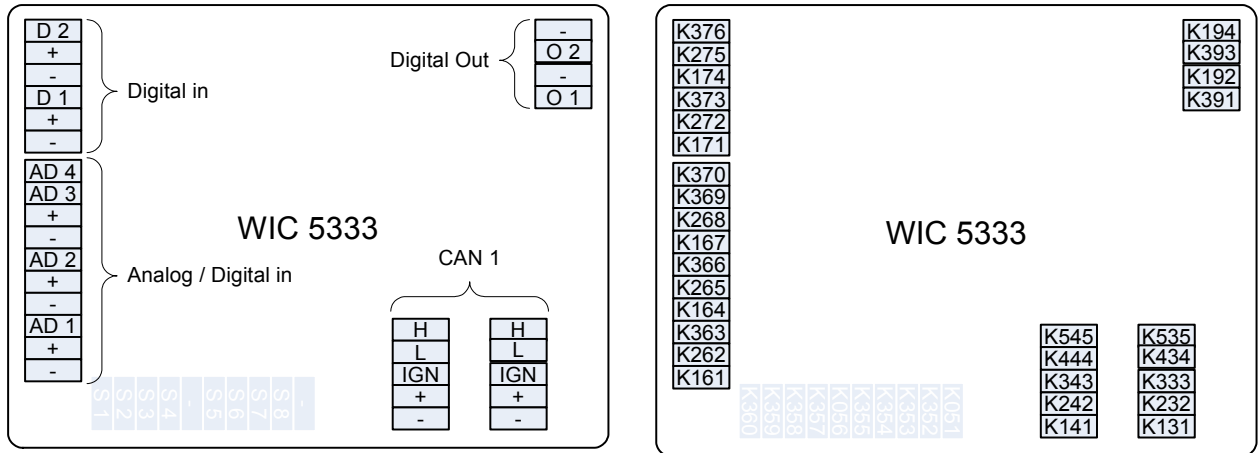

Terminal	Signal	Explanation
K1xx	Supply ÷	The first figure in the terminal number indicates the signal type.
K2xx	Supply +	
K3xx	Ignition	
K4xx	CAN Low	
K5xx	CAN High	
Kx1x	Power	The second figure in the terminal number indicates the number of the plug.
Kxx1	Number	The third figure indicates the terminal number.

## Survey of terminals, CIO 5376

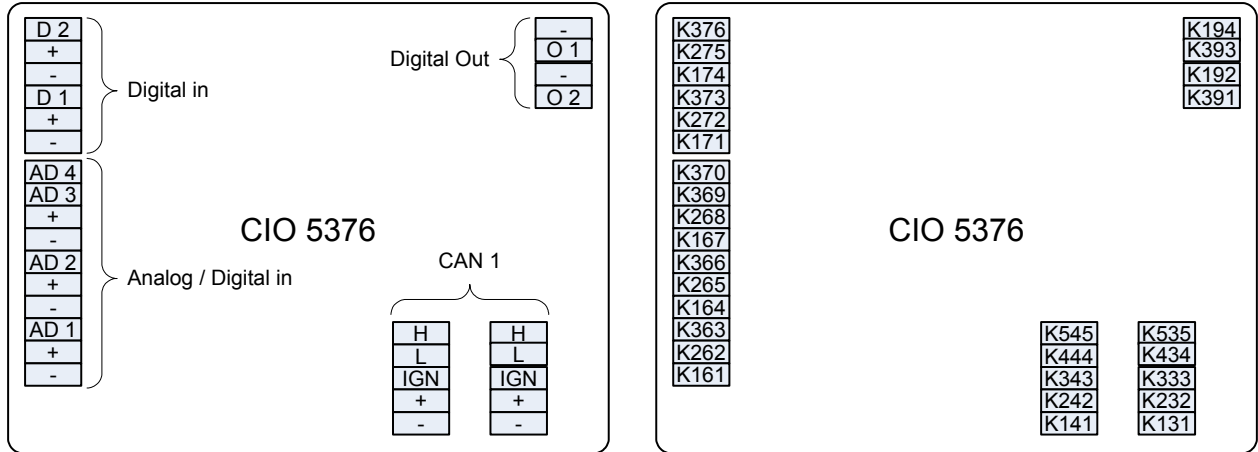

Terminal	Signal	Explanation
K1xx	Supply ÷	The first figure in the terminal number indicates the signal type.
K2xx	Supply +	
K3xx	Ignition	
K4xx	CAN Low	
K5xx	CAN High	
Kx1x	Power	The second figure in the terminal number indicates the number of the plug.
Kxx1	Number	The third figure indicates the terminal number.

### Survey of terminals, ECT 5310

Terminal	Signal	Terminal	Signal
K141	Supply ÷	K131	Supply ÷
K242	Supply +	K232	Supply +
K343	Ignition	K333	Ignition
K444	CAN Low	K434	CAN Low
K545	CAN High	K535	CAN High
K646	Stop (signal)	K636	Stop (signal)
K747	Stop (signal)	K737	Stop (signal)

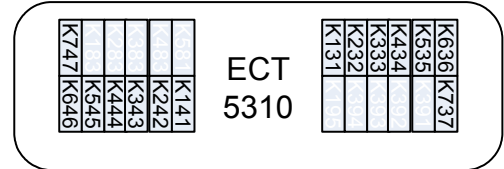
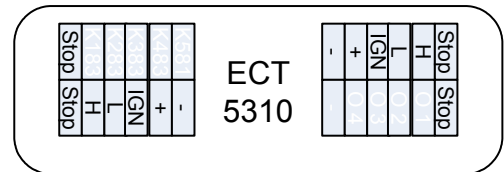

### Survey of terminals, SLC 5363

Terminal	Signal	Terminal	Signal
K141	Supply ÷	K131	Supply ÷
K242	Supply +	K232	Supply +
K343	Ignition	K333	Ignition
K444	CAN Low	K434	CAN Low
K545	CAN High	K535	CAN High
K646	Stop (signal)	K636	Stop (signal)
K747	Stop (signal)	K737	Stop (signal)
K381	Dig. in 1	K391	Dig. Out 1
K382	Dig. in 2	K392	Dig. Out 1
K383	Dig. in 3	K393	Dig. Out 1
K384	Dig. in 4	K394	Dig. Out 1
K185	Supply ÷	K195	Supply ÷

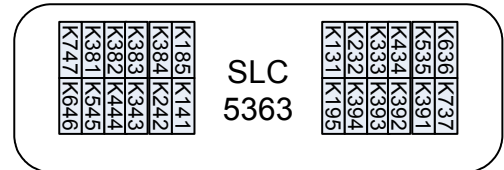
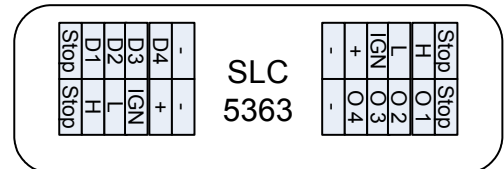

### Survey of terminals, CIO 5374

Terminal	Signal	Terminal	Signal
K141	Supply ÷	K131	Supply ÷
K242	Supply +	K232	Supply +
K343	Ignition	K333	Ignition
K444	CAN Low	K434	CAN Low
K545	CAN High	K535	CAN High
K646	Stop (signal)	K636	Stop (signal)
K747	Stop (signal)	K737	Stop (signal)
K381	Dig. in 1	K391	Dig. Out 1
K382	Dig. in 2	K392	Dig. Out 1
K383	Dig. in 3	K393	Dig. Out 1
K384	Dig. in 4	K394	Dig. Out 1
K185	Supply ÷	K195	Supply ÷

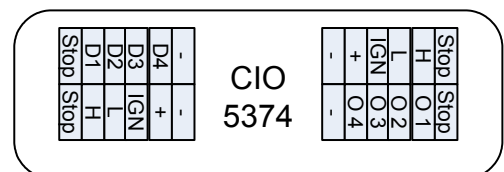

### Survey of terminals, PVEO-DI

The electric activation PVEO-DI on the PVSK-change-over valve is activated ON/OFF from the RCL 5300 and has built-in spool sensors (DI).

The PVEO-DI has two power supplies:

- $U_{DC}$  (A and B) for ON/OFF activation of PVSK.
- $U_{DC2}$  for spool sensors DI-A and DI-B.

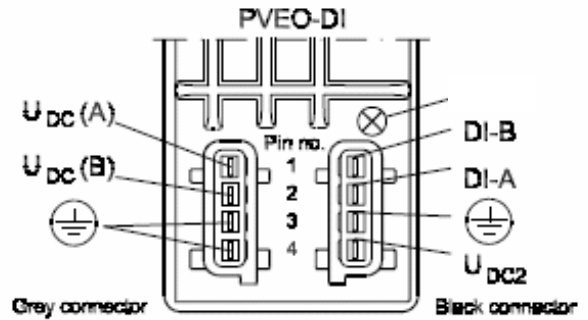

### Survey of terminals, PVED-CC

The PVED-CC activations on the PVG 32 control valve are connected in series (Serial CAN) and have power supply ( $V_{bat+}$  and  $V_{bat-}$ ) and CAN bus (CAN-L and CAN-H) connection for the RCL 5300 controller.

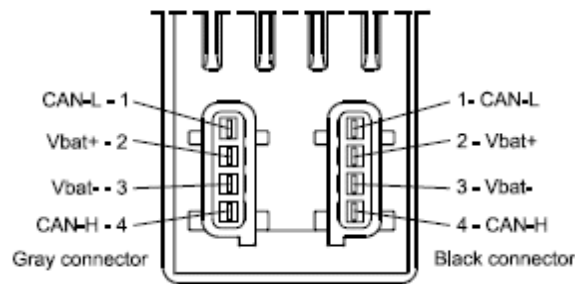

The CAN bus is terminated before the first component and after the last component in the serial connection.

The termination is carried out by connecting a  $120 \Omega$  resistor between the CAN-L and CAN-H.

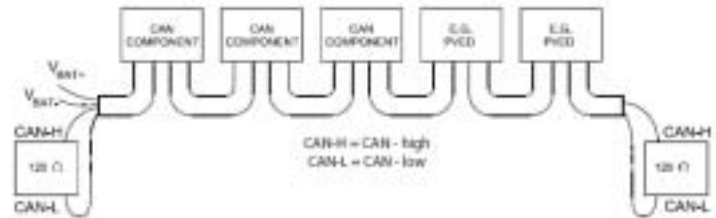

The last PVED-CC in the serial connection is terminated by a plug, which has a built-in  $120 \Omega$  resistor.

