

200-PUMP: 99900120: 20131008



***Model 200***  
***AIR/HYDRAULIC PUMP***

**PARTS AND SERVICE MANUAL**

**IOWA MOLD TOOLING CO., INC.**

BOX 189, GARNER, IA 50438-0189

TEL: 641-923-3711

TECHNICAL SUPPORT FAX: 641-923-2424

MANUAL PART NUMBER 99900120

Iowa Mold Tooling Co., Inc. is an Oshkosh Truck Corporation company.

# TABLE OF CONTENTS

PARAGRAPH	TITLE	PAGE
<b>SECTION 1. DESCRIPTION</b>		
1-1.	DESCRIPTION .....	1-1
1-2.	OPERATION .....	1-1
<b>SECTION 2. SERVICE</b>		
2-1.	GENERAL .....	2-1
2-2.	AIR/HYDRAULIC PUMP .....	2-1
2-2-1.	PUMP DISASSEMBLY .....	2-1
2-2-2.	PUMP ASSEMBLY .....	2-2
2-3.	CLEANING .....	2-3
2-4.	STORAGE .....	2-3
2-5.	TROUBLESHOOTING .....	2-3
<b>SECTION 3. PARTS</b>		
3-1.	GENERAL .....	3-1
3-2.	ORDERING REPAIR PARTS .....	3-1
<b>SECTION 4. LUBRICATION</b>		
4-1.	OIL SELECTION .....	4-1
4-2.	OIL SPECIFICATIONS .....	4-1
4-3.	CONTAMINATION AND TESTING .....	4-1
4-4.	LUBRICATION .....	4-1

# LIST OF ILLUSTRATIONS

FIGURE	TITLE	PART NUMBER	PAGE
B-1.	TRUBLESHOOTING CHART .....		2-3
C-1.	PUMP ASSEMBLY W/HOSE .....	51705747	3-1
C-2.	AIR/HYDRAULIC PUMP - PARTS .....	73051460	3-2
C-2A.	AIR/HYDRAULIC PUMP - DRAWING .....	73051460	3-3
D-1.	HYDRAULIC OIL SPECIFICATIONS .....		4-1

## SECTION 1. DESCRIPTION

### 1-1. DESCRIPTION

The IMT 200 Air/Hydraulic Pump supplies hydraulic fluid pressure to selected tools such as the 210 HP Bead Breaker. It consists of an in-line air and hydraulic cylinder. The ratio of hydraulic fluid pressure generated compared to supply air pressure is 100:1. In other words, 100 PSI out for every 1 PSI in - 100 PSI input air pressure equals 10,000 PSI output pressure.

Depressing the RELEASE pedal causes a decrease in pressure and pressing the PUMP end of the pedal provides fluid pressure.

#### **WARNING**

The air/hydraulic pump is capable of generating fluid pressure up to 10,000 PSI. Make certain the tool in use is held securely and is in proper working condition. Do not continue to operate the pump once the work is completed. Failure to comply with these instructions could result in personal injury or damage to the equipment.

### 1-2. OPERATION

Operation of the unit is as follows:

Connect the hose of the Air/Hydraulic Pump to the hydraulic coupling on the selected tool.

Connect the air supply line to the Air/Hydraulic Pump. Air supply should be 5-10 CFM at 100 PSI to obtain proper operating characteristics. In addition, the air line should be equipped with an air line filter.

Stepping on the PUMP end of the pedal engages the pump, producing the force necessary to run the tool.

Depressing the RELEASE end of the pump pedal will release the pressure.

## SECTION 2. SERVICE

### 2-1. GENERAL

Most malfunctions are a direct result of foreign matter - dirt, dust, water, etc. - entering the pump. Keep all unions clean and capped when the pump is not connected to a tool. If the Air/Hydraulic Pump is to be used only with one tool, it is recommended that the pump be permanently attached to that tool. This is accomplished by removing any quick-disconnects from the tool, inserting a swivel and attaching the hose from the pump directly to the swivel. Use a pipe thread compound when assembling. This will eliminate the possibility of contamination through open couplings.

The pump is relatively easy to service. Some tools will be required for disassembly. These are:

1. Vise
2. Common screwdriver
3. Needle-nosed pliers
4. Ice pick or sharp awl
5. Allen wrenches
6. Open end wrenches
7. Retaining ring pliers
8. Socket wrenches
9. Ratchet
10. Torque wrench

### 2-2. AIR/HYDRAULIC PUMP

Before disassembling the pump, the outside must be thoroughly washed to prevent contaminating the interior. Before washing, remove the pedal (67) by removing one of the "E" retaining rings and sliding the pin (64) out of the hole. Wash thoroughly with warm, soapy water, rinse with clean water and wipe or blow the pump dry.

#### CAUTION

Do not use solvents. Solvents may be corrosive to seals.

Proceed with disassembly in a clean, warm environment - one that is free of dust, dirt, etc. and has a temperature of 70°F or warmer

### 2-2-1. PUMP DISASSEMBLY

To disassemble, proceed as follows (refer to Figure C-2 for parts information):

Remove the twelve self-tapping screws (69) and lift off the cover/pump assembly. Set the reservoir (57) and gasket (55) to one side.

Remove the six socket head screws (61 & 84) and lift off the muffler (42 & 72), the intake air valve body (68), the release valve body (66) and cover (63).

The air valve may be disassembled by removing the socket head screw (36), drawing item 39 and 40 out of the top and items 36 and 38 out of the bottom.

The release valve may be further disassembled by drawing items 1, 44, 45 and 47 out of the bottom.

The pump assembly (under the cover) may also be disassembled.

Lift out the springs (5, 34 & 46) and ball (6).

Clamp the rear head (27) in a vise. Remove the four socket head screws (70).

#### NOTE

It is easier to remove three socket head screws (70) completely and then, using hand pressure to hold the pump body in place, remove the fourth screw Spring tension (20) will cause the pump body to lift away from the cylinder (60).

Carefully lift off the pump body (8), the hydraulic piston, spring guide and spring (13, 20 & 21).

Lift the cylinder (60) off the rear head. Push the air piston out of the cylinder.

Remove the three socket head screws and washers (28 & 29) from the air piston assembly. Remove all parts. The piston poppet (31) can be pulled off the end of the exhaust valve stem (32).

Remove the piston rings and back-up rings (25 & 33) with a small, common screwdriver.

200-PUMP: 99900120: 19920508

Place the pump body (8) in a vise with the cylinder end facing up. Remove the retaining nut (17). The u-cup will have to be pressed out from the other end of the pump body. Remove the cylinder (15) with a 1" socket.

Reposition the pump body in the vise so that the filter (12) is on top. Remove the filter, adapter, copper washer and ball (9, 10, 11 & 12).

Insert a common screwdriver in the slot at the top of the poppet retainer (48). Rotate it back-and-forth to loosen it. Grip the retainer and pull it out of the pump body.

**NOTE**

Socket head screw and washer (3 & 4) are used as a plug. There is no need to remove them. Relief valve (7) is factory preset at 10,000 PSI. There should be no need for its removal. If it is defective, replace the entire relief valve assembly. The new assembly is also preset. Do not disassemble before installation or the setting will be incorrect.

Disassembly is complete.

## 2-2-2. PUMP ASSEMBLY

The pump is assembled as follows:

**NOTE**

Use all components supplied with the seal kit.

Insert the release valve components (48, 49, 50, 51, 52, 53 & 54) into the pump body (8).

Position the pump body in a vise with the filter port up. Install the filter, adapter, copper washer and ball (9, 10, 11, 12 & 58).

Reposition the pump body with the cylinder end up. Install the cylinder, u-cup, retainer nut, and copper gasket (14, 15, 16 & 17).

Clamp the rear head (27) in a vise and insert the back-up ring (59).

Assemble the piston (22, 23, 24, 25, 26, 28, 29, 30, 31, 32 & 33). Apply Loctite® to the threads of the socket head screws (29) and torque them to 50 - 55 in-lbs.

Lubricate the piston rings and the inside of the air cylinder with oil. Insert the piston into the air cylinder and squirt more oil around the circumference of the piston. Work the piston back-and-forth to distribute the oil.

2-2

Position the cylinder/piston group on the rear head with the groove on the inside of the cylinder toward the top of the rear head.

Position the back-up ring (59) on the pump body.

Position the spring guide, hydraulic piston and spring (13, 20 & 21) over the air piston. Align the pump body so the hydraulic piston slides through the retainer nut (17).

Push the pump body down against the cylinder. Install the four socket head screws and washers and torque them to 85 - 90 in-lbs.

**NOTE**

The easiest way to assemble the rear head, cylinder and pump body is to start one screw and get it finger tight. That will take up the spring tension and make it easier to install the others.

Position the pump assembly in the vise with the top up. Place new gaskets on the pump body and rear head. Oil will help hold them in position.

Place the cover on top of the gaskets and insert the o-rings (35 & 2).

With your fingers, press item 1, 44, 45 and 47 into the ports in the release valve body. Place the ball (6) and springs (5 & 46) into the ports of the pump body. Install item 58 (must be pressed into place).

Align the release valve body on the cover and start the four socket head screws. Do not tighten the screws.

Install items 36, 37, 38 and 40 in the air valve body. Place the spring (34) in the port in the rear head.

Position the muffler (42 & 72) between the valve bodies and secure the valve bodies in place (torque the screws to 25 - 30 in-lbs.).

Position the pedal and slide the pin through the valve body and pedal. Secure it with the other "E" retaining ring.

Position the assembled pump in the reservoir. Fill the reservoir with oil and prime the pump.

To prime the pump, connect the air supply line to the air inlet. Depress the PUMP end of the pedal and hold down the release valve with a common screwdriver. Allow the pump to cycle 15 - 20 times. Remove the screwdriver and depress the PUMP end of the pedal. If pressure builds, the pump has primed; if not, repeat this step until it does build pressure.

**2-3. CLEANING**

Wash the exterior of the pump with warm, soapy water. Rinse with clean water and dry using compressed air. Pay particular attention to the release valve area of the pump. This may become encrusted with dirt to the extent that the release mechanism will no longer function.

**CAUTION**

Do not use solvent. Solvents may be corrosive to the seals and damage them.

**2-4. STORAGE**

Anytime the pump is stored, it is wise to wash any spilled chloride or other harmful chemicals from its exterior. Use warm, soapy water and be certain to rinse with clear water and dry thoroughly. Doing so on a regular schedule will increase the life of the equipment.

**2-5. TROUBLESHOOTING**

Figure B-1 lists problems, probable causes and solutions for the pump. refer to the parts drawings.

SYMPTOM	PROBABLE CAUSE
PUMP DOES NOT RECIPROCATE	Air piston stuck. 1. Check cylinder bore of pump for contamination or lack of lubrication. 2. Piston poppet not sealing - Replace.
PUMP RECIPROCATES BUT NO PRESSURE.	Check prime. 1. Depress both air valve and hydraulic release valve at the same time.
PUMP WILL NOT HOLD SYSTEM PRESSURE	1. Outlet check ball not sealing properly - Correct or Replace. 2. Release valve mechanism not sealing properly. Check pin, ball, release poppet and poppet retainer - Corect or Replace.
PUMP WILL NOT BUILD TO MAXIMUM PRESSURE. NO VISIBLE SIGNS OF LEAKAGE	1. Check air supply (5 - 10 CFM @ 100 PSI). 2. Check for internal leakage. A. Release valve mechanism. B. Low relief valve setting. C. Inlet check ball not seating properly - Correct or Replace.
PUMP WILL NOT BUILD MAXIMUM PRESSURE. VISIBLE SIGN OF LEAKAGE THROUGH AIR EXHAUST MUFFLER.	1. Check piston sub-assembly. A. Replace copper gasket and assemble in vertical position. B. Replace piston packing.

**FIGURE B-1. TROUBLESHOOTING CHART**

## SECTION 3. PARTS

### 3-1. GENERAL

This section contains the parts drawings and parts lists for the IMT 200HP Air/Hydraulic Pump.

### 3-2. ORDERING REPAIR PARTS

To order parts:

1. Give the model number.
2. Give the serial number located on the side of the pump.
3. Give the part number, description and quantity required.

Place your order with Iowa Mold Tooling Co., Inc., Box 189, Garner, IA 50438, telephone 641-923-3711, Fax 641-923-2424; or your nearest distributor.

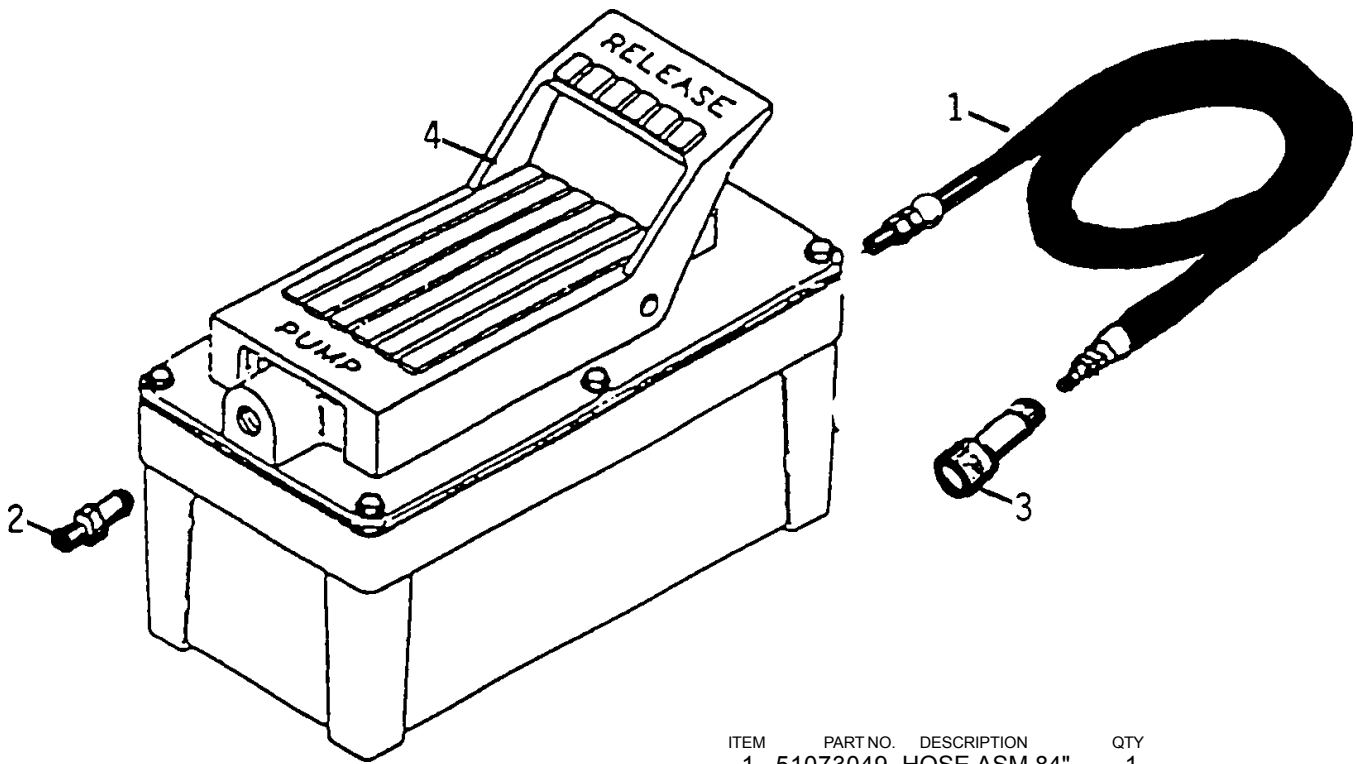

ITEM	PART NO.	DESCRIPTION	QTY
1.	51073049	HOSE ASM 84"	1
2.	72532047	DISCONNECT NIPPLE 1/4MPT-AIR	1
3.	72533424	DISCONNECT COUPLER 3/8FPT	1
4.	73051460	PUMP - AIR/HYD 5-QT (SEE DWG)	1
5.	99900120	MANUAL-200 AIR/HYD PUMP	1

**FIGURE C-1. PUMP ASSEMBLY W/HOSE (51705747)**

ITEM	PART NO.	DESCRIPTION	QTY	COMMENTS
1.	70141439	CHECK VALVE BODY .....	1	
2.	7Q072218	O-RING .....	1	*
3.	72060702	CAP SCR 1/4-20X3/8 SH .....	1	TORQUE TO 90 - 100 IN-LBS.
4.	70024221	WASHER 1/4X3/8X.03 COPPER .....	1	*
5.	70141141	SPRING .....	1	*
6.	72066438	BALL 9/32 DIA .....	1	
7.	73054282	RELIEF VALVE 10,000 PSI .....	1	
8.	70141438	PUMP BODY .....	1	
9.	72066437	BALL 1/4 DIA .....	1	*
10.	70024222	WASHER-COPPER .....	1	*
11.	70142929	FILTER ADAPTER-SHORT .....	1	TORQUE TO 40 - 50 FT-LBS (OILED).
12.	70048097	FILTER ASM .....	1	
13.	70141136	PISTON .....	1	
14.	70024215	WASHER-COPPER .....	1	*
15.	70142928	CYLINDER .....	1	TORQUE TO 90 - 100 FT-LBS (OILED).
16.	76391235	U-CUP .....	1	*
17.	72062184	RETAINER NUT .....	1	* TORQUE TO 80 - 100 IN-LBS, MILD HEAT MAY BE NEEDED TO REMOVE, REINSTALL WITH LOCTITE® #277
20.	70141441	SPRING .....	1	*
21.	70142927	SPRING GUIDE .....	1	
22.	70141442	SPRING .....	1	*
23.	7Q072115	O-RING .....	1	*
24.	70029505	PISTON BODY .....	1	
25.	7T66G027	PISTON RING .....	2	*
26.	76391344	GASKET .....	1	
27.	70142358	REAR HEAD .....	1	
28.	72063047	WASHER #10 LOCK .....	3	
29.	72060680	CAP SCR #10-24X1/2 SH .....	3	TORQUE TO 50 - 55 IN-LBS, REINST ALL USING LOCTITE®.
30.	70141432	END PLATE-PISTON .....	1	
31.	76039495	PISTON POPPET .....	1	*
32.	70142926	EXHAUST VALVE STEM .....	1	
33.	7Q072141	O-RING .....	2	*
34.	70141435	SPRING .....	1	*
35.	7Q072210	O-RING .....	2	*
36.	72060656	CAP SCR #8-32X1/4 SH .....	1	
37.	70141434	SEAL GUIDE .....	1	
38.	70141291	AIR VALVE POPPET .....	1	*
39.	7Q072011	O-RING .....	1	*
40.	70141433	ACTUATOR BUTTON .....	1	*
41.	76391349	GASKET .....	1	*
42.	70141421	MUFFLER .....	1	
43.	76391348	GASKET .....	1	*
44.	70141428	RELEASE VALVE BUTTON .....	1	
45.	7Q072010	O-RING .....	1	*
46.	70141437	SPRING .....	1	*
47.	7Q072010	O-RING .....	2	*
48.	70141284	POPPET RETAINER .....	1	
49.	70141285	RELEASE VALVE POPPET .....	1	
50.	72066432	BALL 3/32 DIA .....	1	*
51.	70142925	BALL RETAINER .....	1	
52.	70141427	SPRING .....	1	*
53.	7Q072012	O-RING .....	1	*
54.	70141085	DOWEL PIN 1/16X5/8 .....	1	*
55.	76392468	RESERVOIR GASKET .....	1	*
56.	76392110	GASKET-RUBBER .....	1	*
57.	70034266	RESERVOIR 5-QT PLASTIC .....	1	
58.	72063162	WASHER .....	1	
59.	76391345	BACK-UP RING .....	2	
60.	70141424	AIR CYLINDER .....	1	LOCATE GROOVE TOWARD TOP NEAR COVER PLATE.
61.	72060685	CAP SCR #10-24X1-1/4 SH .....	4	TORQUE TO 50 - 60 IN-LBS.
62.	72532689	FILLER PLUG .....	1	
63.	70142924	COVER PLATE .....	1	
64.	70141422	PIN .....	1	
65.	72066556	RETAINING RING .....	2	
66.	70142923	RELEASE VALVE BODY .....	1	
67.	73029148	FOOT PEDAL .....	1	
68.	70141086	INTAKE AIR VALVE BODY .....	1	
69.	72601409	SCR #10X1 HWH SLFTPG .....	12	TORQUE TO 25 - 30 IN-LBS.
70.	72060727	CAP SCR 1/4-20X4 SH .....	4	TORQUE TO 85 - 95 IN-LBS (OILED). CROSS TORQUE IN 30 IN-LB INCREMENTS.
72.	76391347	FOAM TUBE 3" .....	1	
76.	70142359	SPRING .....	1	
77.	72601273	CAP SCR .....	1	TORQUE TO 12 - 18 IN-LBS.
78.	72601274	SCREW .....	1	
80.	76391654	FOAM TUBE .....	1	
81.	72532688	RELIEF VALVE FITTING .....	1	TORQUE TO 75 - 80 IN-LBS.
82.	70142357	SPRING CLIP .....	1	
83.	72063131	WASHER .....	2	
84.	72060687	CAP SCR #10-24X1-3/4 SH .....	2	TORQUE TO 50 - 60 IN-LBS.
85.	70392467	DECAL - MODEL NO. .....	1	
86.	76392469	REPAIR KIT (INCLUDES ITEMS W/*) ..	1	

**SEE FOLLOWING PAGE FOR DRAWING**

**FIGURE C-2. AIR/HYDRAULIC PUMP (73051460)**



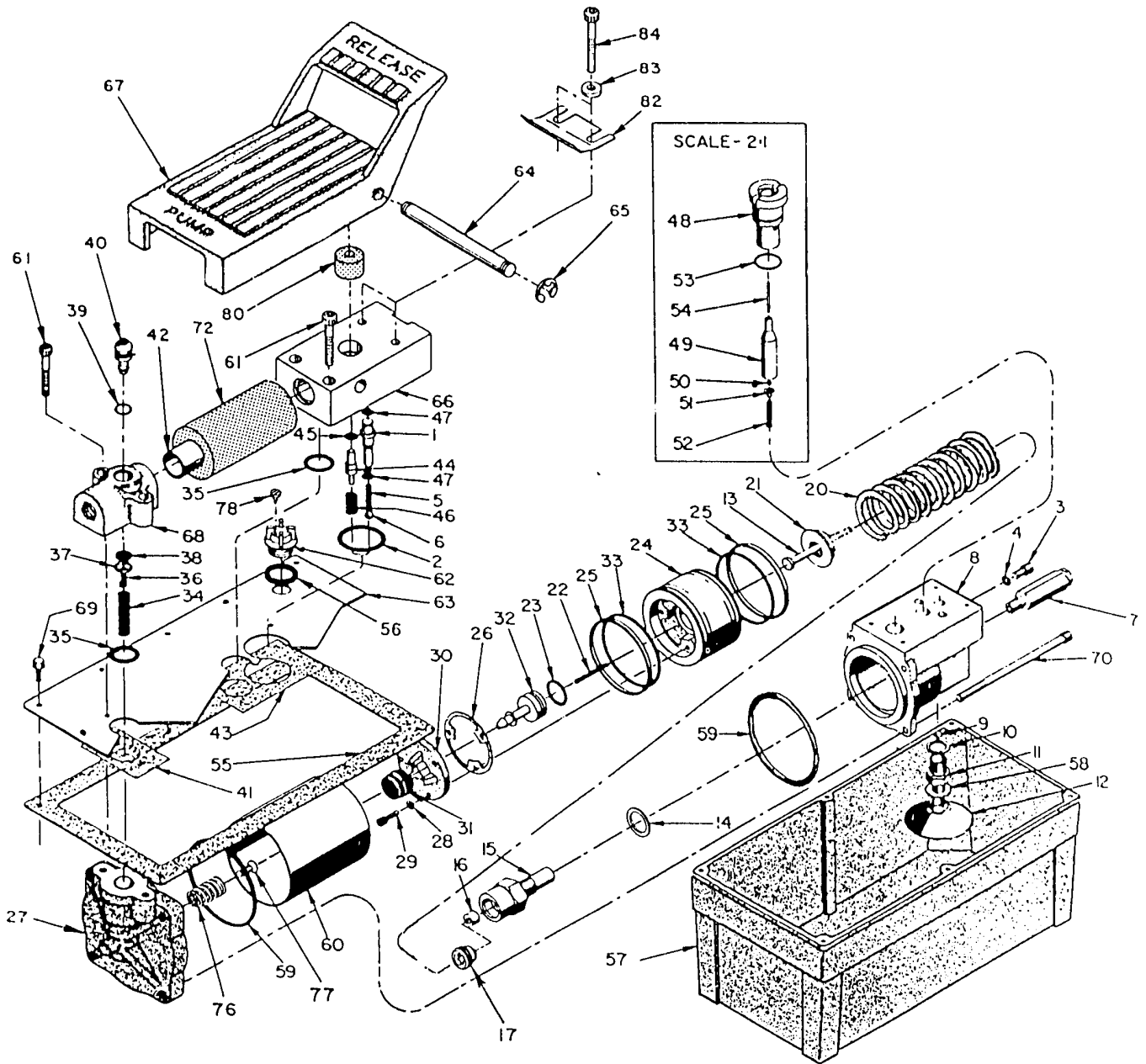

**FIGURE C-2A. AIR/HYDRAULIC PUMP (73051460)**

## SECTION 4. LUBRICATION

### 4-1. OIL SELECTION

Minimum viscosity specifications for hydraulic oil to be used in the system are given in Figure D-1. Any major oil company can supply products which meet these requirements.

Oils selected by the user for this class of equipment, in addition to meeting viscosity requirements, should have the following additives:

1. Antifoam inhibitors
2. Antioxidant inhibitors
3. Rust resistant additives
4. Antiwear additives

### 4-2. OIL SPECIFICATIONS

Figure E-1 provides oil specifications for a full range of operating temperatures encountered in the temperate zones. Arctic conditions present special requirements which are not within the scope of the table and must be given special consideration and individual analysis. Consult your local oil supplier for the proper fluid for working under these severe conditions.

### 4-3. CONTAMINATION AND TESTING

Contamination of the hydraulic oil by solvents, water, dust or other abrasives will result in a premature breakdown of the oil's antifoam, lubrication, anti-rust and viscosity properties. Prolonged exposure to water or high temperatures (above 180°F) will cause an increase in the oxidation rate, producing varnish forming materials and sludge in the oil.

Periodically a sample of the hydraulic oil in the system should be drawn off and its condition checked for breakdown. To check oil quality:

1. Place oil sample in a clean glass.
2. Smell oil to detect a burnt or rancid odor.
3. Examine the oil for a cloudy or dark color.
4. Allow the sample to stand for several minutes and inspect it for water which will settle to the bottom. Water can result from a leak in the system or condensation due to temperature extremes.

When any of these conditions is observed, the system should be purged and filled with new oil.

### 4-4. LUBRICATION

If the pump is operated on a continuous duty cycle for extended periods, the manufacturer recommends an automatic air line oiler be installed in the air inlet as close to the pumping unit as possible. Set the unit to feed approximately 1 drop of oil per minute into the system. Use SAE No. 10 oil.

Check the oil level in the reservoir after every 10 hours of use. The oil should come to within 1/2" of the filler plug with all rams retracted. Drain and replenish the reservoir with an approved, high-grade hydraulic oil after every 300 hours of use.

AMBIENT TEMPERATURE RANGE	0 - 90°F	BELOW 32°F	32 - 90°F	ABOVE 90°F
MIN. POUR POINT, °F	-30	-25+	+10	+10
MAX. VISCOSITY, SSU @ 0°F	4000	4000	-----	-----
MIN. VISCOSITY, SSU @ 100°F	140 - 195	100 - 130	150 - 200	200 - 315
MIN. VISCOSITY, SSU @ 210°F	48	41 - 43	43	47
MIN. VISCOSITY INDEX	139	90	90	90

**FIGURE D-1. HYDRAULIC OIL SPECIFICATIONS**

200-PUMP: 99900120: 19920508

The information within this manual has been compiled and checked but errors do occur. To provide our customers with a method of communicating those errors we have provided the Manual Change Request form below. In addition to error reporting, you are encouraged to suggest changes or additions to the manual which would be of benefit to you. We cannot guarantee that these additions will be made but we do promise to consider them. When completing the form, please write or print clearly. Submit a copy of the completed form to the address listed below.

## MANUAL CHANGE REQUEST

DATE	PRODUCT MANUAL	MANUAL PART NO.
SUBMITTED BY		
COMPANY		
ADDRESS		
CITY, STATE, ZIP		
TELEPHONE		

ERROR FOUND

LOCATION OF ERROR (page no.): \_\_\_\_\_

DESCRIPTION OF ERROR: \_\_\_\_\_

---

---

---

---

---

---

---

---

---

---

REQUEST FOR ADDITION TO MANUAL

DESCRIPTION OF ADDITION: \_\_\_\_\_

---

---

---

---

REASON FOR ADDITION: \_\_\_\_\_

---

---

---

MAIL TO: IOWA MOLD TOOLING Co., Inc.  
Box 189,  
Garner IA 50438-0189  
ATTN: Technical Publications

200-PUMP: 99900120: 20000706

This parts manual is provided to the user to assist in servicing the equipment. It is the property of Iowa Mold Tooling Co., Inc and, as such, may not be reproduced either whole or in part, whether by chemical, electrostatic, mechanical or photographic means without the expressed written permission of an officer of Iowa Mold Tooling Co., Inc. One manual is provided with each piece of new equipment and additional manuals may be obtained at a nominal price.

**IOWA MOLD TOOLING CO., INC.**  
BOX 189, GARNER, IA 50438-0189  
TEL: 641-923-3711  
TECHNICAL SUPPORT FAX: 641-923-2424