Manual # 99904616

20/138DL Technical Specifications

Revision Date 20120912



IOWA MOLD TOOLING CO., INC.

PO Box 189

Garner, IA 50438

Tel: 641-923-3711 FAX: 641-923-2424

Website: <http://www.imt.com>

Copyright © 2012 Iowa Mold Tooling Co., Inc.
All rights reserved

No part of this publication may be reproduced, stored in a retrieval system, or transmitted in any form or by any means, electronic, mechanical, photocopying, recording or otherwise without the prior written permission of Iowa Mold Tooling Co., Inc.

Iowa Mold Tooling Co., Inc. is an Oshkosh Corporation company.

Contents

Revisions	ii
Technical Data and Charts	3
20/138DL Technical Specifications.....	4
20/138DL Pressure Settings.....	5
20/138DL Pressure Settings with Remote Control	6
Winch Technical Data	7
20/138DL Lifting Capacities	8
20/138DL K2 Capacity Chart.....	9
20/138DL K3 Capacity Chart.....	10
20/138DL K4 Capacity Chart.....	11
20/138DL K5 Capacity Chart.....	12
20/138DL K6 Capacity Chart.....	13
20/138DL K7 Capacity Chart.....	14
20/138DL K8 Capacity Chart.....	15
20/138DL Geometric Configuration.....	16
Stabilizer Dimensions, Fixed Legs, 18 tm up	17
Stabilizer Dimensions, Swing-up, 18 tm up	18
Stowed Dimensions	19
Mounting Dimensions.....	20
20/138DL Swing Clearance.....	21
Hydraulic Schematics	23
Hydraulic Diagram - 20/138DL Danfoss 6-Function Radio.....	24
Hydraulic Diagram - 20/138DL Danfoss 7-Function Radio.....	25
Hydraulic Diagram - 20/138DL Hydrocontrol 6-Function Manual.....	26
Hydraulic Diagram - 20/138DL Hydrocontrol 6-Function Radio	27

Revisions

DATE	LOCATION	DESCRIPTION
20090813		Added swing clearance drawing.
20100118	Geometric configuration	Added stabilizer length and extension, stabilizer drawings.
20111214	Specs, Stabilizer drawings	ECN 11628 - Updated stabilizer wording.
20120502	Specifications	Updated crane weight to include mounting kit, tank.
20120910	Drawings	Added stowed dimensions, mounting dimensions, and winch settings drawings.

CHAPTER 1

Technical Data and Charts

In This Chapter

20/138DL Technical Specifications	3
20/138DL Pressure Settings	5
20/138DL Pressure Settings with Remote Control.....	5
Winch Technical Data	7
20/138DL Lifting Capacities	8
20/138DL K2 Capacity Chart.....	9
20/138DL K3 Capacity Chart.....	10
20/138DL K4 Capacity Chart.....	11
20/138DL K5 Capacity Chart.....	12
20/138DL K6 Capacity Chart.....	13
20/138DL K7 Capacity Chart.....	14
20/138DL K8 Capacity Chart.....	15
20/138DL Geometric Configuration.....	16
Stabilizer Dimensions, Fixed Legs, 18 tm up	17
Stabilizer Dimensions, Swing-up, 18 tm up.....	18
Stowed Dimensions.....	19
Mounting Dimensions.....	20
20/138DL Swing Clearance.....	21

20/138DL Technical Specifications

20/138DL	2-HYDRAULIC	3-HYDRAULIC	4-HYDRAULIC	5-HYDRAULIC	6-HYDRAULIC	7-HYDRAULIC	8-HYDRAULIC
Crane Rating*	133,085 ft lb (18.4 tm)	130,195 ft lb (18 tm)	126,580 ft lb (17.5 tm)	123,685 ft lb (17.1 tm)	120,070 ft lb (16.6 tm)	117,175 ft lb (16.2 tm)	115,005 ft lb (15.9 tm)
Maximum Horizontal Reach	27' 3" (8.3 m)	33' 10" (10.3 m)	41' 0" (12.5 m)	48' 7" (14.8 m)	56' 5" (17.2 m)	63' 8" (19.4 m)	71' 2" (21.7 m)
Maximum Vertical Reach	35' 1" (10.7 m)	42' 0" (12.8 m)	49' 3" (15.0 m)	56' 5" (17.2 m)	64' 4" (19.6 m)	71' 10" (21.9 m)	79' 1" (24.1 m)
Maximum Capacity	15,740 lb (7140 kg)	15,035 lb (6820 kg)	14,395 lb (6530 kg)	13,780 lb (6250 kg)	13,205 lb (5990 kg)	12,655 lb (5740 kg)	12,215 lb (5540 kg)
Max Cap @ Max Reach	4895 lb (2220 kg)	3640 lb (1650 kg)	2735 lb (1240 kg)	2050 lb (930 kg)	1520 lb (690 kg)	1080 lb (490 kg)	815 lb (370 kg)
Crane Weight **	4300 lb (1950 kg)	4640 lb (2105 kg)	5050 lb (2290 kg)	5355 lb (2430 kg)	5635 lb (2555 kg)	5865 lb (2660 kg)	6050 lb (2745 kg)
Hook Approach							
Vertical	7' 3" (2.21 m)	7' 6" (2.29 m)	7' 10" (2.38 m)	8' 1" (2.47 m)	8' 5" (2.56 m)	8' 8" (2.65 m)	9' 0" (2.74 m)
Horizontal	2' 3" (0.69 m)	2' 5" (0.74 m)	2' 7" (0.79 m)	2' 9" (0.84 m)	2' 11" (0.89 m)	3' 1" (0.94 m)	3' 3" (1.0 m)
Center of Gravity - Stored							
Vertical	2' 7" (795 mm)	2' 8" (820 mm)	2' 9" (840 mm)	2' 10" (855 mm)	2' 10" (870 mm)	2' 11" (890 mm)	3' (910 mm)
Horizontal (C/L RotTo Bridge)	12.8" (325 mm)	12.4" (315 mm)	12.0" (305 mm)	11.4" (290 mm)	10.8" (275 mm)	10.4" (265 mm)	10.0" (255 mm)

* Crane rating (ft-lb) is the rated load (lb) multiplied by the respective distance (ft) from centerline of rotation with all extensions retracted and the inner and outer booms in a horizontal position, per ANSI B30.22. ** Crane weight is for standard crane with tank & 4-bolt mounting kit. Does not include stabilizers, oil.

20/138DL SPECIFICATIONS

Stabilizer Pad Diameter	7" (175 mm)
Crane Storage Height	7' 6" (2295 mm)
Mounting Space	2' 11" (880 mm)
Rotational Torque	17,555 ft lb (2.4 tm)
Rotation	400°
Optimum Pump Performance	14.5 gpm (55 L/min)
System Pressure	4,785 psi (330 Bar)
Oil Reservoir Capacity	23.8 gal (90 L)
Stabilizer Extension Span	
Standard (manual out / hydraulic down)	18' 3" (5575 mm)
Weight	605 lb (275 kg)
Option (hydraulic out / hydraulic down)	21' 2" (6455 mm)
Weight	785 lb (355 kg)
*** Maximum swing clearance radius required is 25" (635 mm) at 8' (2430 mm) from top of chassis frame.	

MINIMUM CHASSIS SPECIFICATIONS

Front Axle Rating (GAWR)	14,000 lb (6350 kg)
Rear Axle Rating (GAWR)	40,000 lb (18,145 kg)
Resistance To Bending Moment	2,000,000 in-lb (230,425 kg-m)

20/138DL Pressure Settings

WORKING PRESSURE ON MAIN-RELIEF VALVES & PORT RELIEF VALVES			
Function	Direction	Port	Pressure Setting
Main-relief valve			4785 psi (330 bar)
Rotation system	Right	A	P
	Left	B	P
Boom cylinder	Down	A	1450 psi (100 bar)
	Up	B	4930 psi (340 bar)
Jib cylinder	Up	A	4930 psi (340 bar)
	Down	B	2900 psi (200 bar)
Extension cylinders	Extend	A	P
	Retract	B	P
Rotator	Right	A	2900 psi (200 bar)
	Left	B	2900 psi (200 bar)
Grab	Open	A	2900 psi (200 bar)
	Close	B	2900 psi (200 bar)
Separate stabilizer valve		All	2175 psi (150 bar)

WORKING PRESSURE ON LOAD-HOLDING VALVES			
Function	Direction	Port	Opening Pressure
Boom cylinder			5075 psi (350 bar)
Jib cylinder			5075 psi (350 bar)
Rotation system			2685 psi (185 bar)
Extension cylinders	Extend	A	3045 psi (210 bar)
	Retract	B	6235 psi (430 bar)

PRESSURE SETTING FOR LOAD-MOMENT LIMITATION (LMB)	
Load moment limitation (LMB)	4640 psi (320 bar)
HDL	4205 psi (290 bar)

MAXIMUM PUMP PERFORMANCE	
Pump performance	14.5 gal/min (55 l/min)

20/138DL Pressure Settings with Remote Control

WORKING PRESSURE ON MAIN-RELIEF VALVES & PORT RELIEF VALVES				
Function	Direction	Port	Port-Relief Valve Pressure Setting	Load-Sense Pressure Adjustment
Main-relief valve			4785 psi (330 bar)	4785 psi (330 bar)
Rotation system	Right	A	P	2610 psi (180 bar)
	Left	B	P	2610 psi (180 bar)
Boom cylinder	Down	A	1815 psi (125 bar)	1450 psi (100 bar)
	Up	B	5075 psi (350 bar)	5075 psi (350 bar)
Jib cylinder	Up	A	5075 psi (350 bar)	5075 psi (350 bar)
	Down	B	2755 psi (190 bar)	2320 psi (160 bar)
Extension cylinders	Extend	A	P	-
	Retract	B	P	-
Rotator	Right	A	P	725 - 4350 psi (50-300 bar)
	Left	B	P	725 - 4350 psi (50-300 bar)
Grab	Open	A	P	725 - 4350 psi (50-300 bar)
	Close	B	P	725 - 4350 psi (50-300 bar)
Winch (1.5 metric T)	Lift	A	P	2320 psi (160 bar)
	Lower	B	P	2320 psi (160 bar)
Winch (2.5 metric T)	Lift	A	P	2685 psi (185 bar)
	Lower	B	P	2685 psi (185 bar)
Separate stabilizer valve		All	2175 psi (150 bar)	2175 psi (150 bar)

WORKING PRESSURE ON LOAD-HOLDING VALVES

Function	Direction	Opening Pressure
Rotation System	Right	2685 psi (185 bar)
	Left	2685 psi (185 bar)
Boom cylinder	Up	5075 psi (350 bar)
	Down	-
Jib cylinder	Up	5075 psi (350 bar)
	Down	3045 psi (210 bar)
Extension cylinders	Extend	3045 psi (210 bar)
	Retract	6235 psi (430 bar)

PRESSURE SETTINGS FOR LOAD-MOMENT LIMITATION (LMB)

Load moment limitation (LMB)	4570 psi (315 bar)
HDL	4135 psi (285 bar)

MAXIMUM PUMP PERFORMANCE

Pump performance	18.5 gal/min (70 l/min)
------------------	-------------------------

Winch Technical Data

	1.5 T Winch (P9) (3305 lb / 1500 kg)	2.5 T Winch (P15) (5510 lb / 2500 kg)
PERFORMANCE (at 2175 psi (150 bar))		
Maximum wire pull - 1st layer	3305 lb (1500 kg)	5510 lb (2500 kg)
Maximum wire pull - 2nd layer	3020 lb (1370 kg)	5070 lb (2300 kg)
Maximum wire pull - 3rd layer	2278 lb (1260 kg)	4630 lb (2100 kg)
Maximum wire pull - 4th layer	2580 lb (1170 kg)	4300 lb (1950 kg)
WIRE SPEED (at 10.5 gpm (40 l/min))		
Maximum wire speed - 1st layer	72 ft/min (22 m/min)	79 ft/min (24 m/min)
Maximum wire speed - 2nd layer	79 ft/min (24 m/min)	85 ft/min (26 m/min)
Maximum wire speed - 3rd layer	85 ft/min (26 m/min)	92 ft/min (28 m/min)
Maximum wire speed - 4th layer	92 ft/min (28 m/min)	98 ft/min (30 m/min)
WEIGHTS		
Tare weight, winch	143 lb (65 kg)	198 lb (90 kg)
Fixed parts (valve section, brackets, hoses, etc.)	110 lb (50 kg)	110 lb (50 kg)
Wire 10 mm dia x 50 m	66 lb (30 kg)	66 lb (30 kg)
Spare parts, single snatch block	66 lb (30 kg)	66 lb (30 kg)
Spare parts, double snatch block	88 lb (40 kg)	88 lb (40 kg)

20/138DL Lifting Capacities

20/138DL - 2 Hydraulic

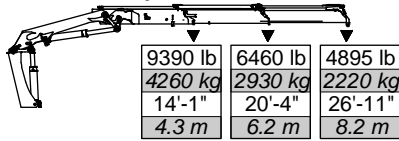

9390 lb	6460 lb	4895 lb
4260 kg	2930 kg	2220 kg
14'-1"	20'-4"	26'-11"
4.3 m	6.2 m	8.2 m

20/138DL - 3 Hydraulic

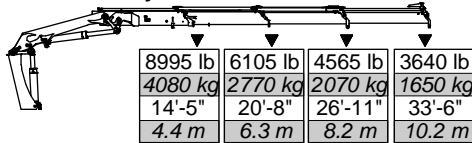

8995 lb	6105 lb	4565 lb	3640 lb
4080 kg	2770 kg	2070 kg	1650 kg
14'-5"	20'-8"	26'-11"	33'-6"
4.4 m	6.3 m	8.2 m	10.2 m

20/138DL - 4 Hydraulic

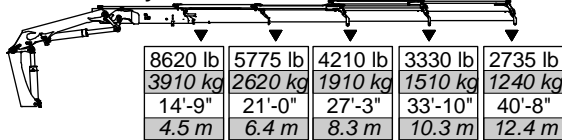

8620 lb	5775 lb	4210 lb	3330 lb	2735 lb
3910 kg	2620 kg	1910 kg	1510 kg	1240 kg
14'-9"	21'-0"	27'-3"	33'-10"	40'-8"
4.5 m	6.4 m	8.3 m	10.3 m	12.4 m

20/138DL - 5 Hydraulic

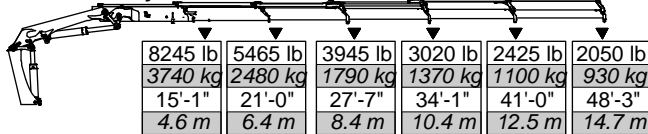

8245 lb	5465 lb	3945 lb	3020 lb	2425 lb	2050 lb
3740 kg	2480 kg	1790 kg	1370 kg	1100 kg	930 kg
15'-1"	21'-0"	27'-7"	34'-1"	41'-0"	48'-3"
4.6 m	6.4 m	8.4 m	10.4 m	12.5 m	14.7 m

20/138DL - 6 Hydraulic

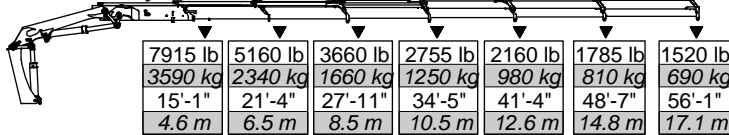

7915 lb	5160 lb	3660 lb	2755 lb	2160 lb	1785 lb	1520 lb
3590 kg	2340 kg	1660 kg	1250 kg	980 kg	810 kg	690 kg
15'-1"	21'-4"	27'-11"	34'-5"	41'-4"	48'-7"	56'-1"
4.6 m	6.5 m	8.5 m	10.5 m	12.6 m	14.8 m	17.1 m

20/138DL - 7 Hydraulic

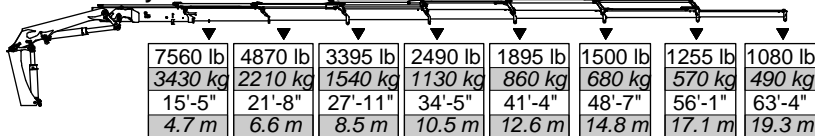

7560 lb	4870 lb	3395 lb	2490 lb	1895 lb	1500 lb	1255 lb	1080 lb
3430 kg	2210 kg	1540 kg	1130 kg	860 kg	680 kg	570 kg	490 kg
15'-5"	21'-8"	27'-11"	34'-5"	41'-4"	48'-7"	56'-1"	63'-4"
4.7 m	6.6 m	8.5 m	10.5 m	12.6 m	14.8 m	17.1 m	19.3 m

20/138DL - 8 Hydraulic

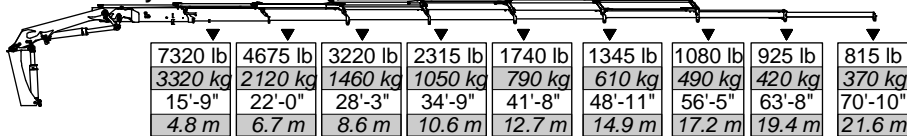

7320 lb	4675 lb	3220 lb	2315 lb	1740 lb	1345 lb	1080 lb	925 lb	815 lb
3320 kg	2120 kg	1460 kg	1050 kg	790 kg	610 kg	490 kg	420 kg	370 kg
15'-9"	22'-0"	28'-3"	34'-9"	41'-8"	48'-11"	56'-5"	63'-8"	70'-10"
4.8 m	6.7 m	8.6 m	10.6 m	12.7 m	14.9 m	17.2 m	19.4 m	21.6 m

20/138DL K2 Capacity Chart

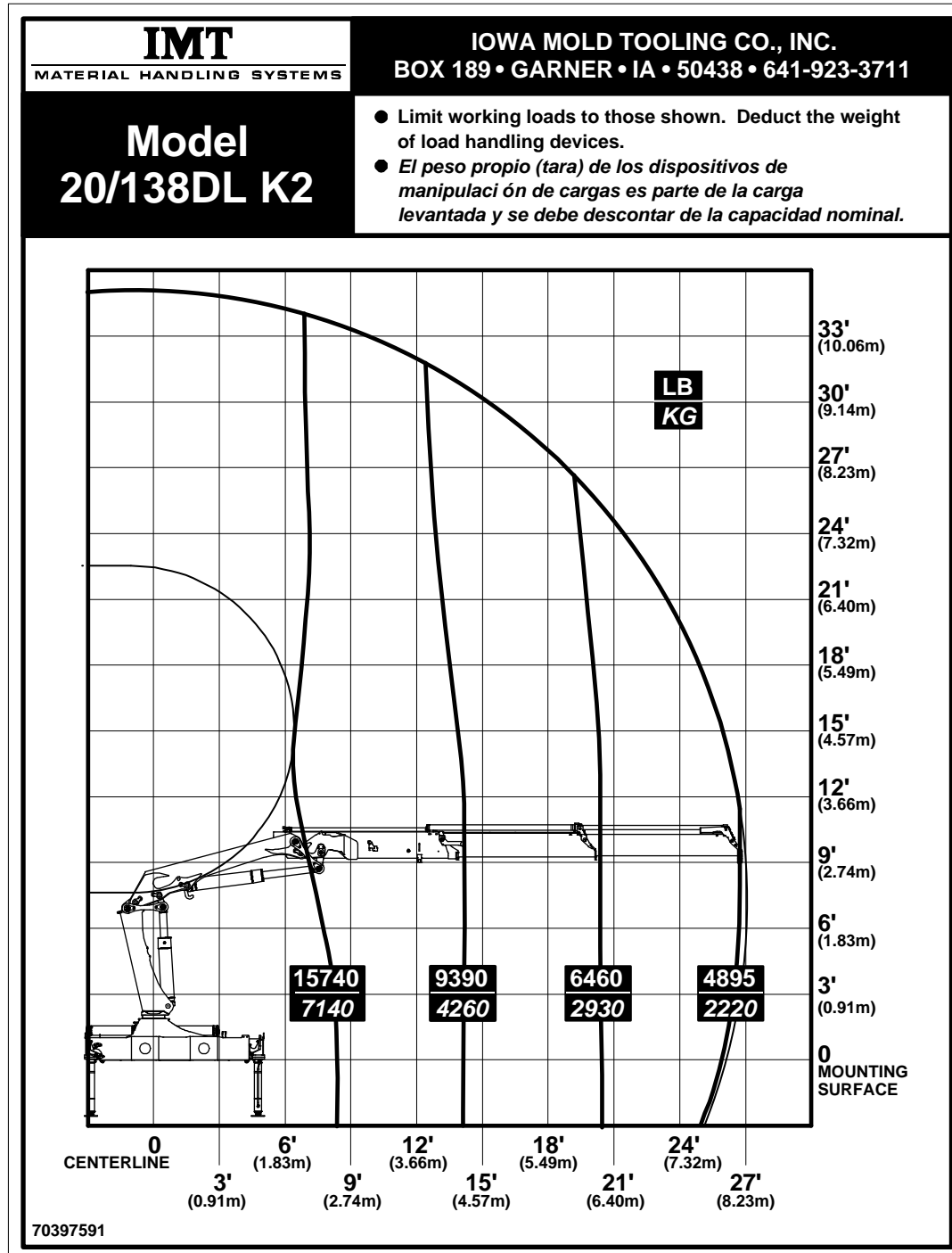

20/138DL K3 Capacity Chart

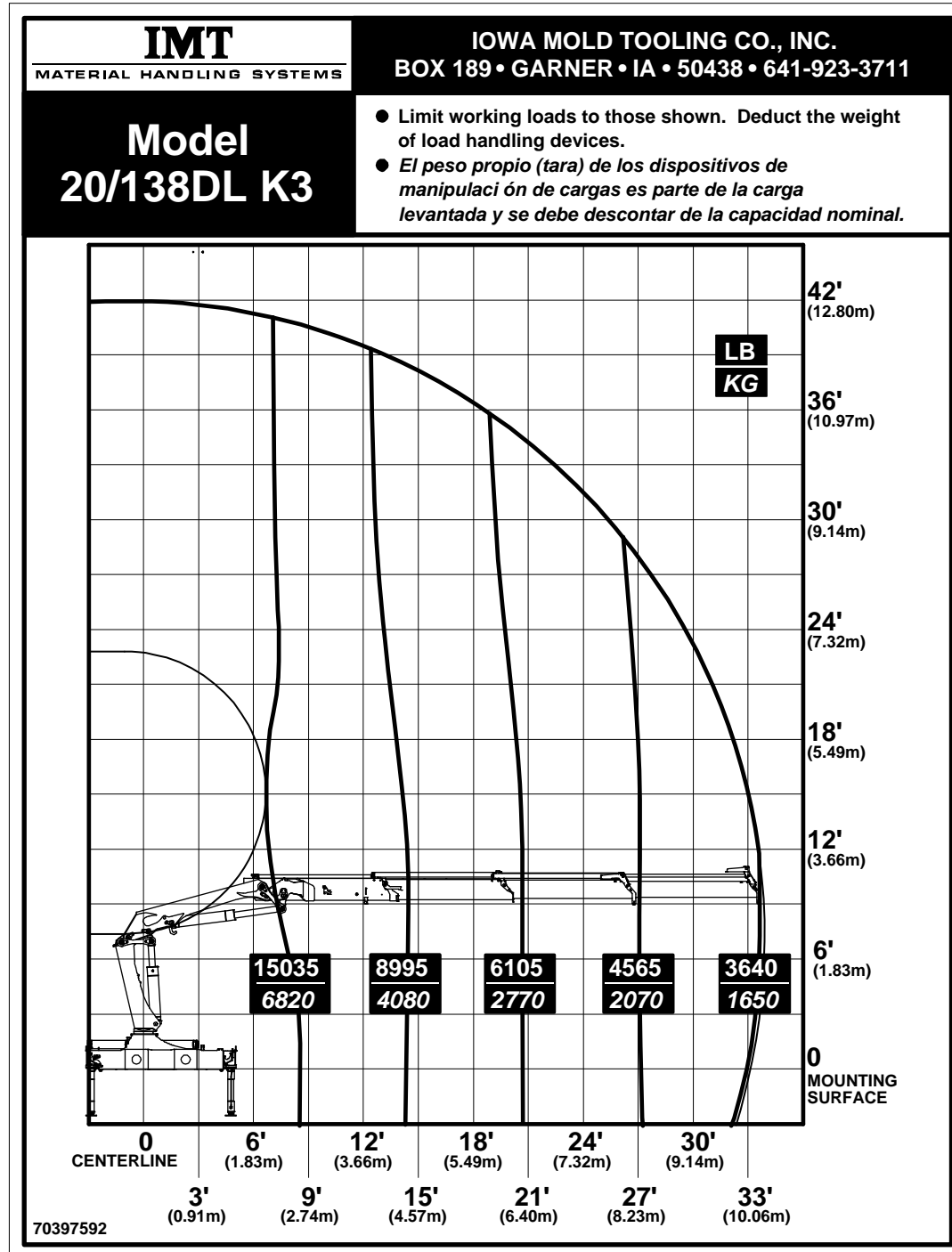

20/138DL K4 Capacity Chart

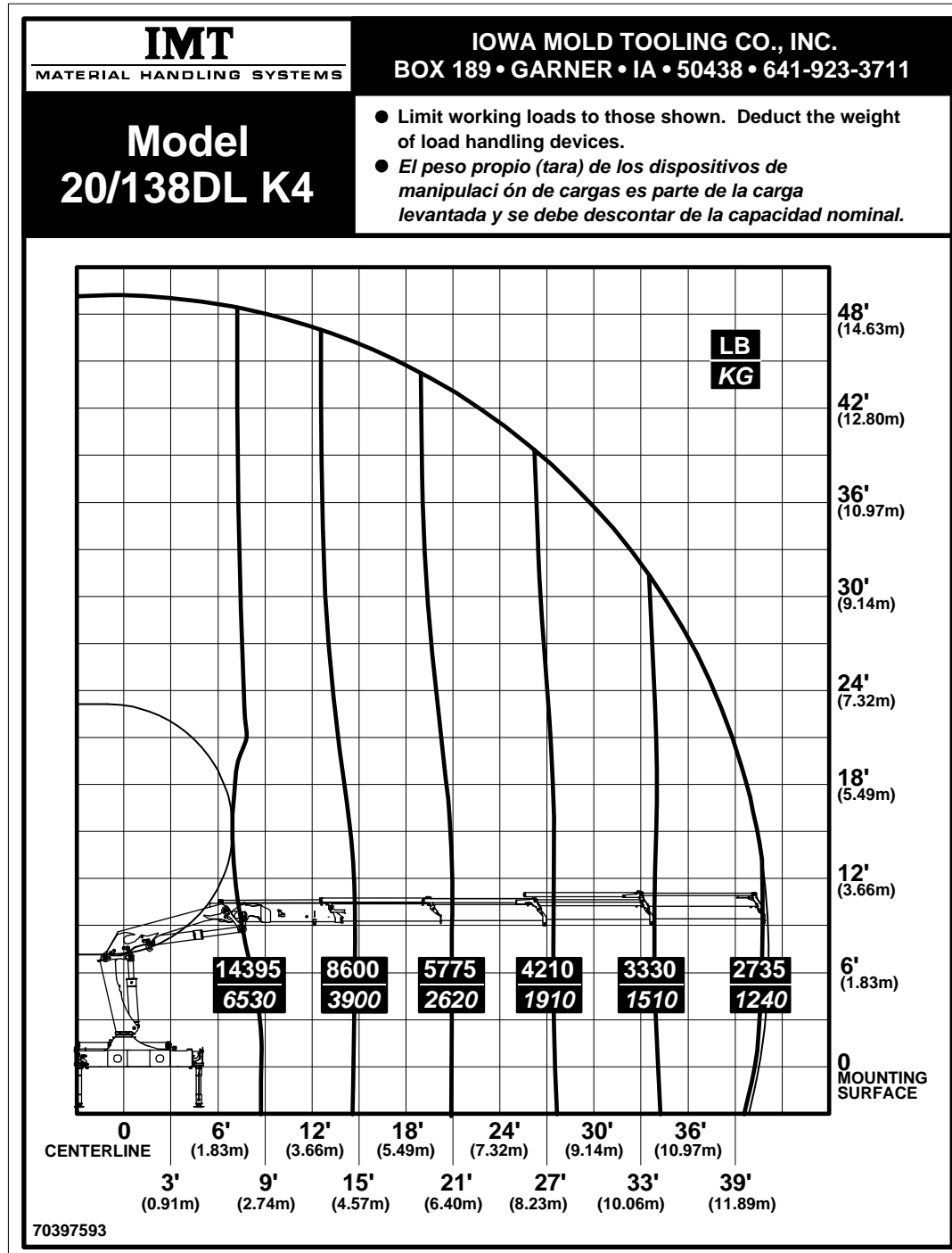

20/138DL K5 Capacity Chart

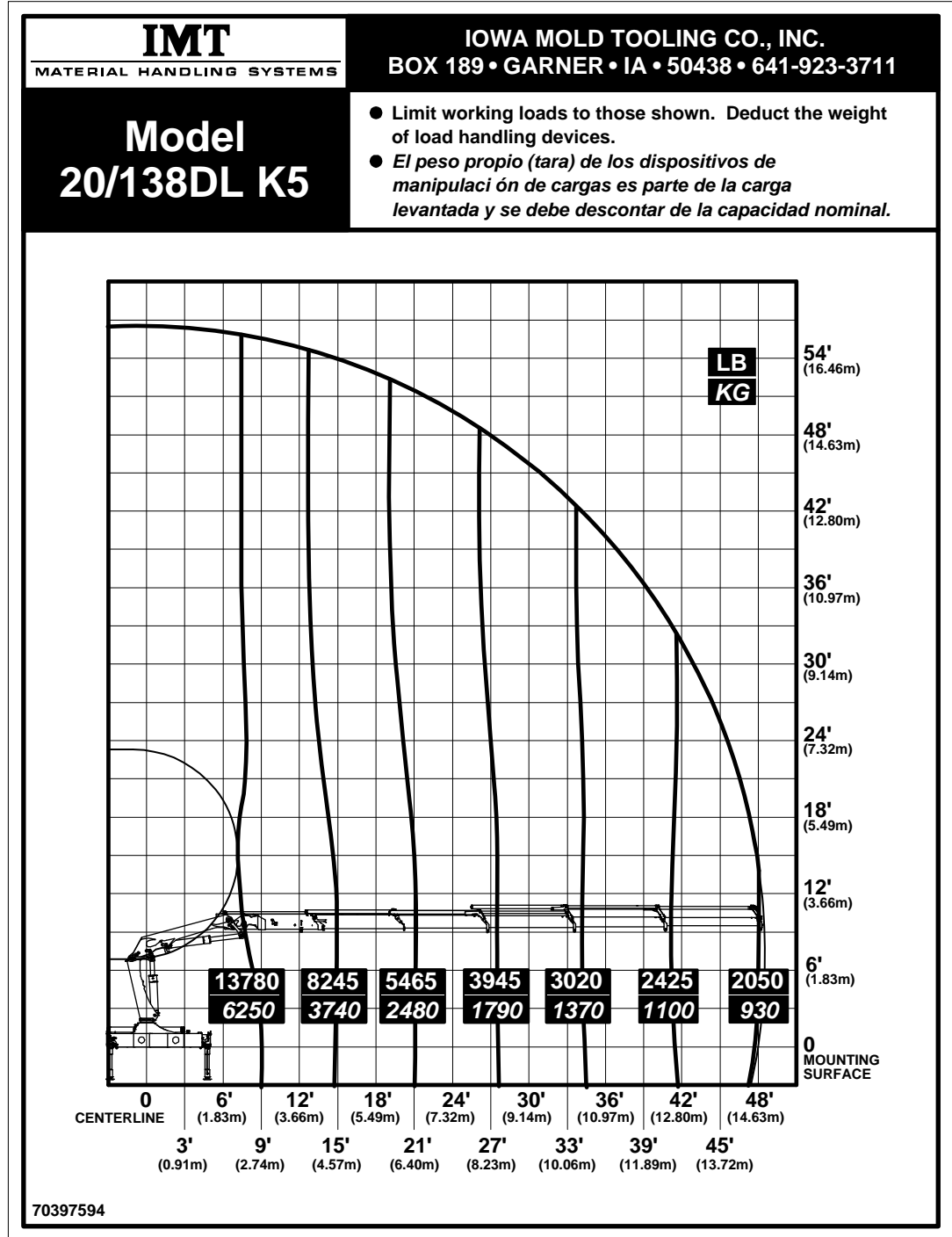

20/138DL K7 Capacity Chart

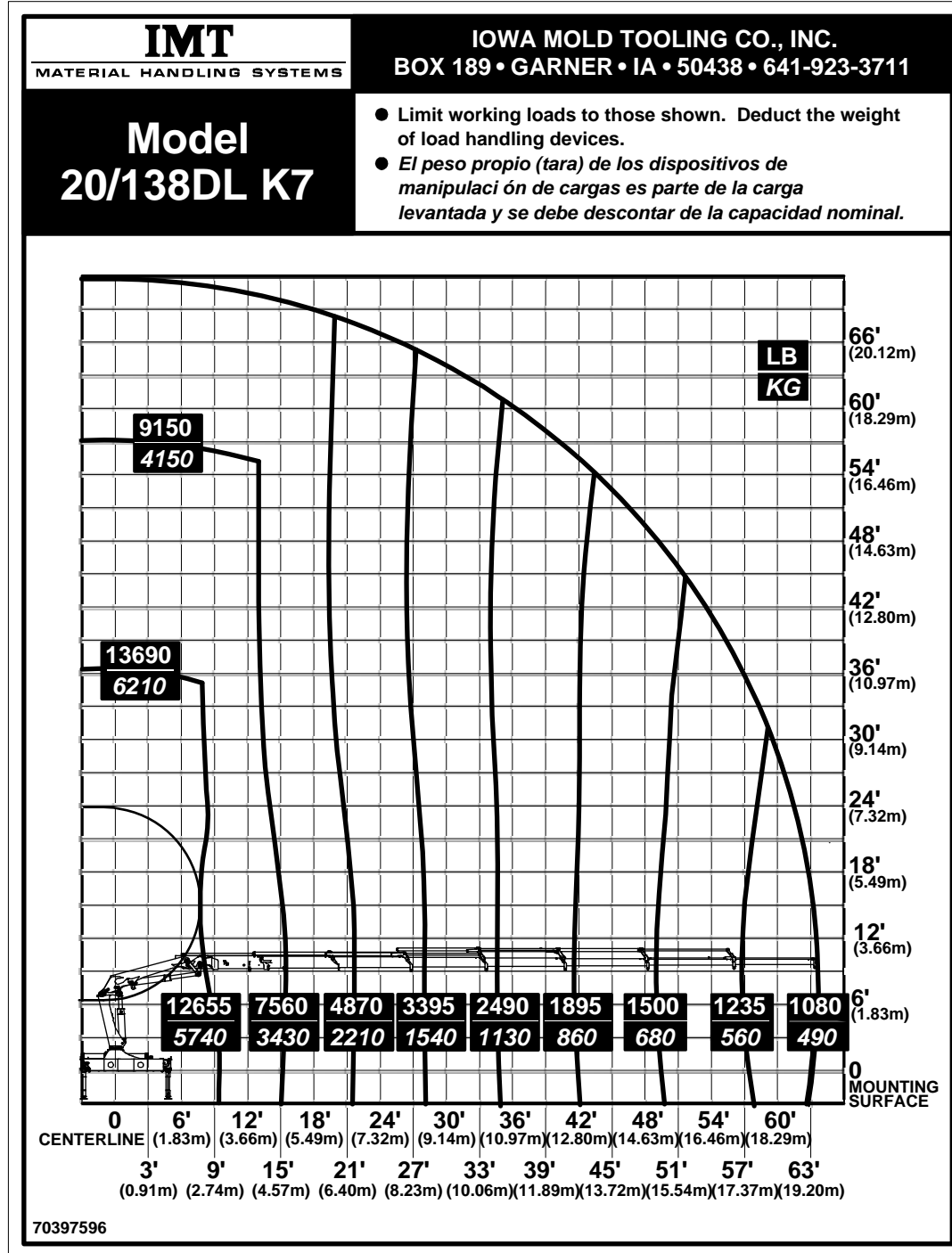

20/138DL K8 Capacity Chart

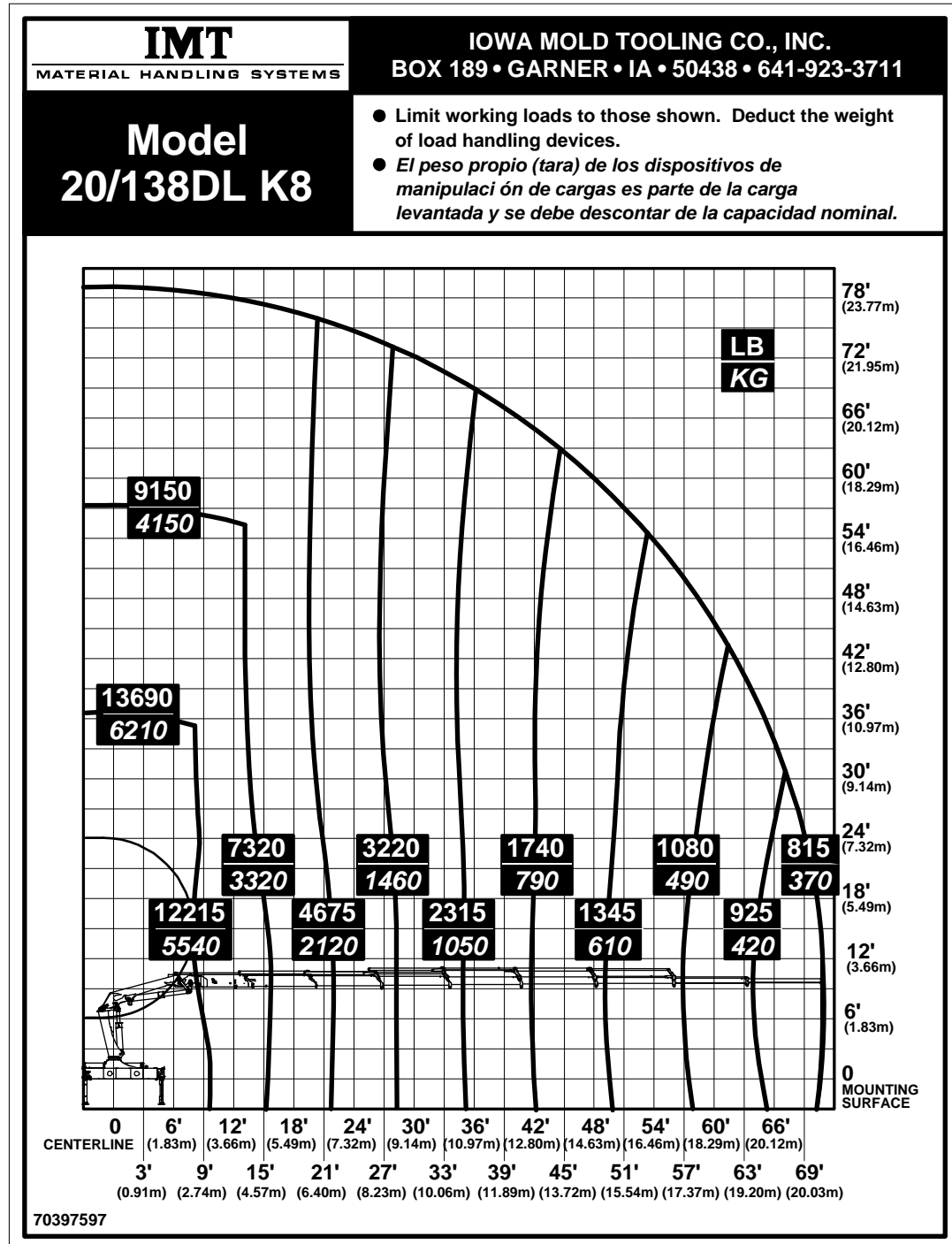

20/138DL Geometric Configuration

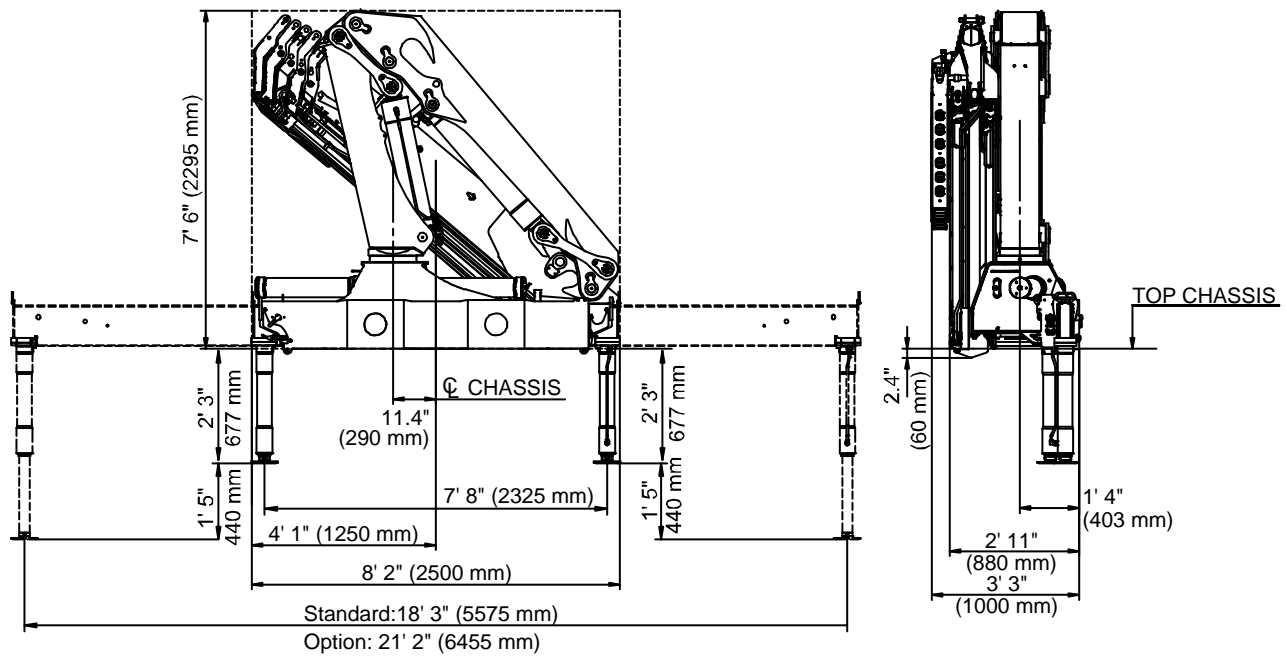
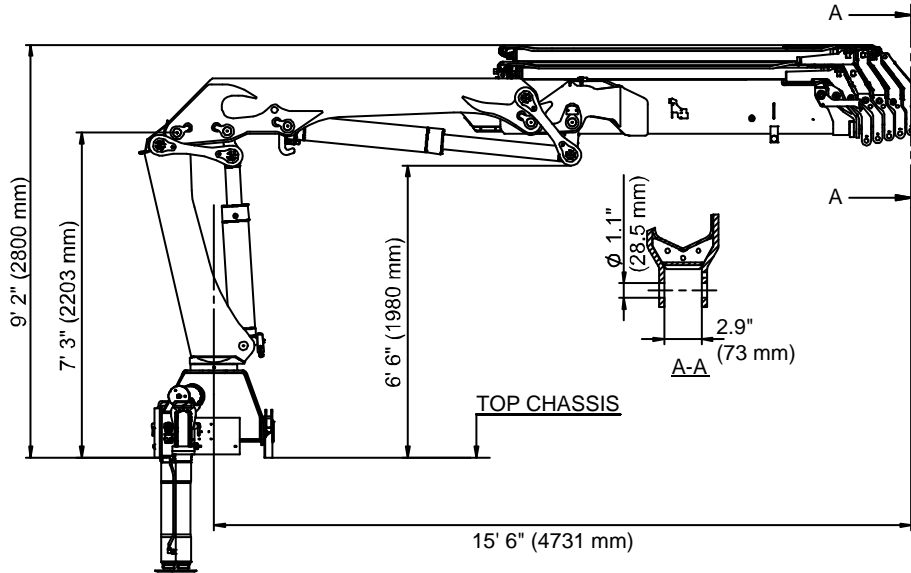

Stabilizer Dimensions, Fixed Legs, 18 tm up

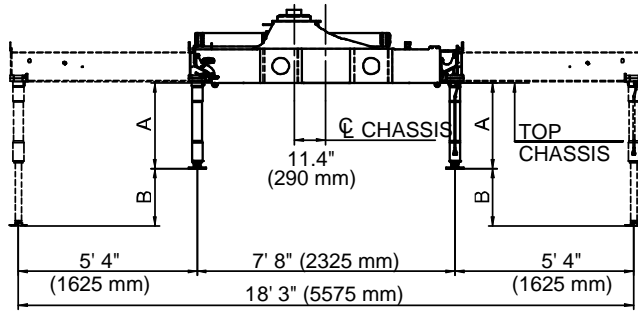

STANDARD
(Hydraulic Out /
Hydraulic Down)

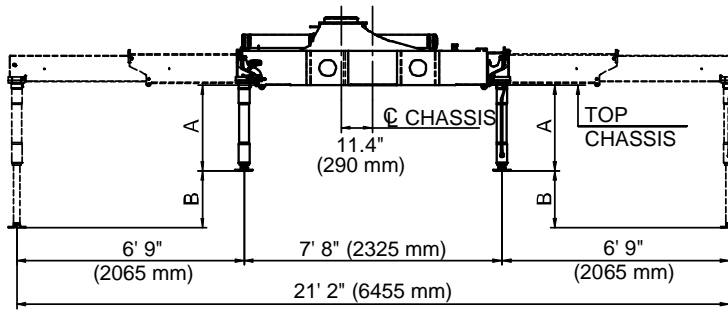



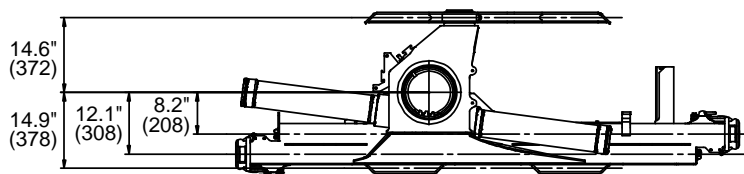
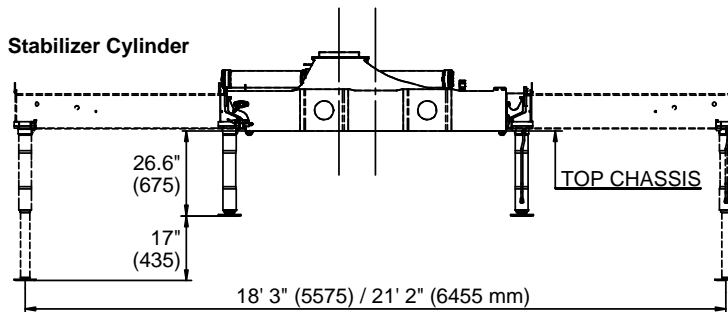

OPTION 1
(Extra Wide
Hydraulic Out /
Hydraulic Down)

A	2' 3" (677 mm)	2' 6" (777 mm)	2' 11" (877 mm)	3' 2" (977 mm)
B	1' 5" (440 mm)	1' 8" (515 mm)	1' 8" (515 mm)	1' 8" (515 mm)

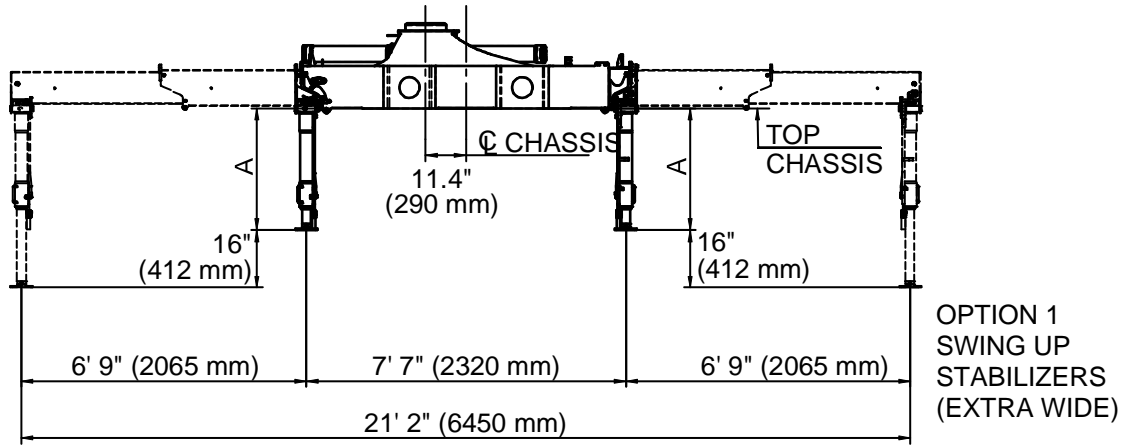
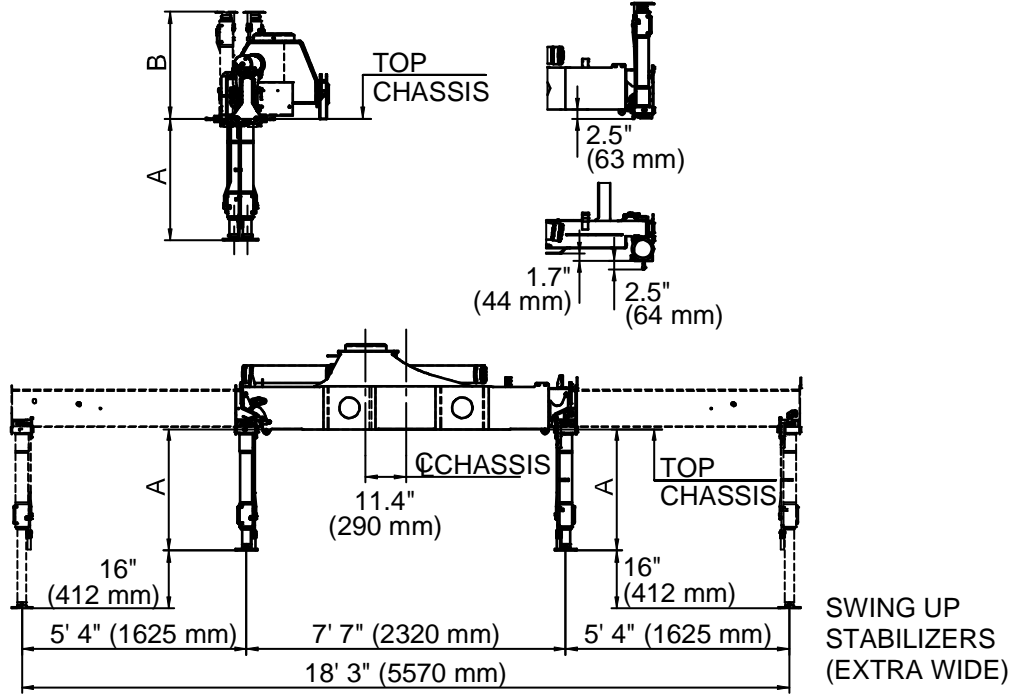

Stabilizer Dimensions, Swing-up, 18 tm up



			
A	35" (879 mm)	39" (979 mm)	42.5" (1079 mm)
B	30.5" (777 mm)	34.4" (877 mm)	38.4" (977 mm)

Stowed Dimensions

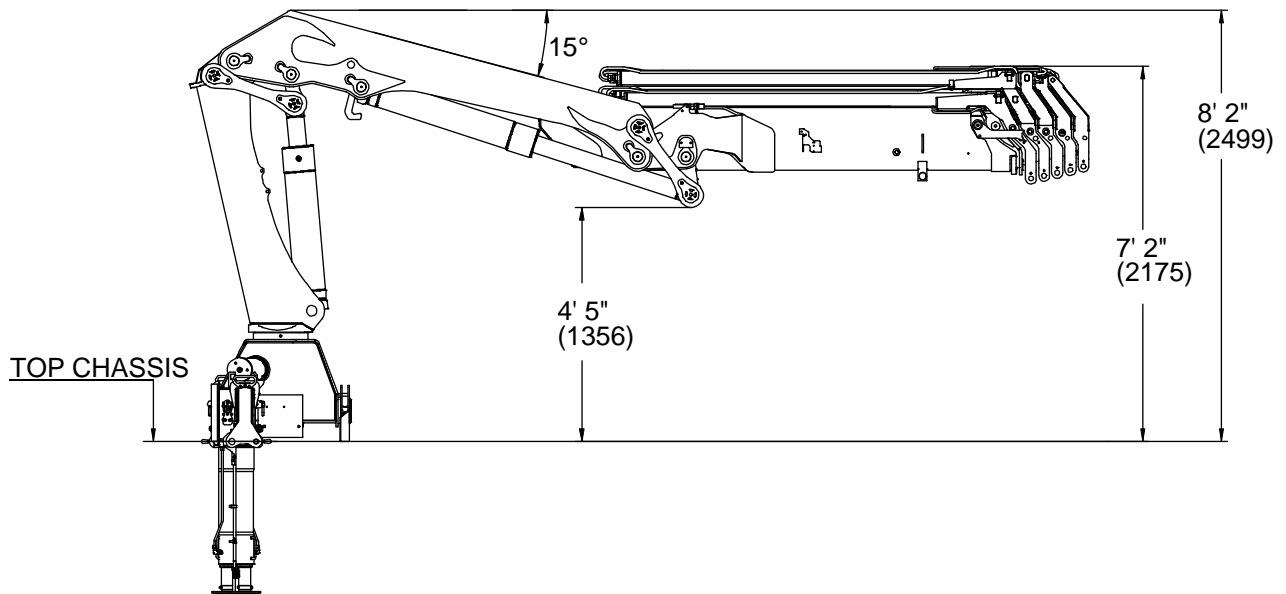
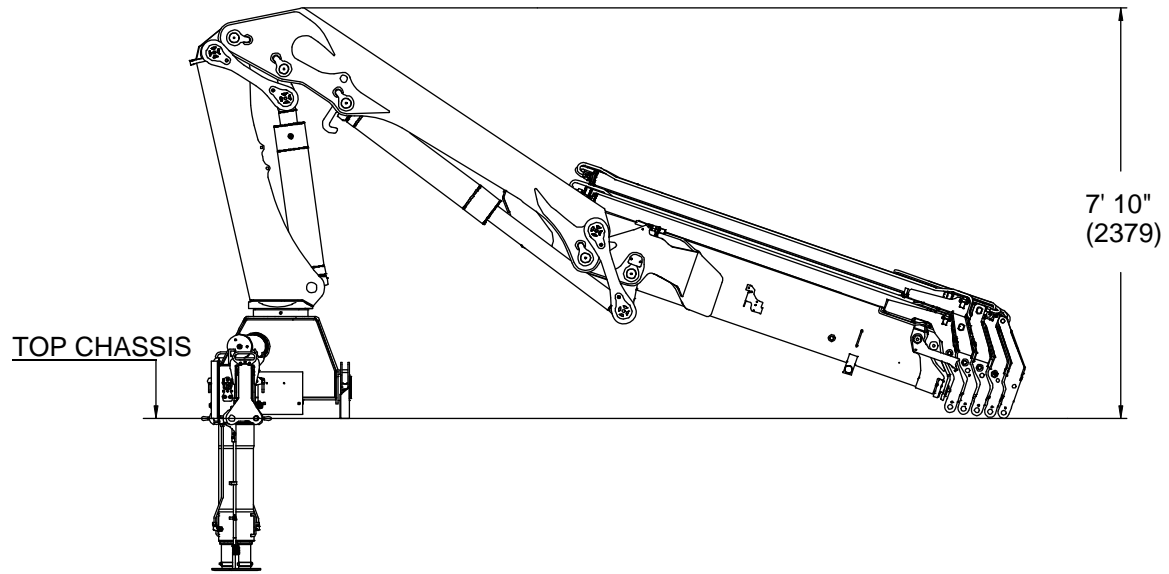

Mounting Dimensions

MOUNTING KIT 8 x M24x2 BOLTS

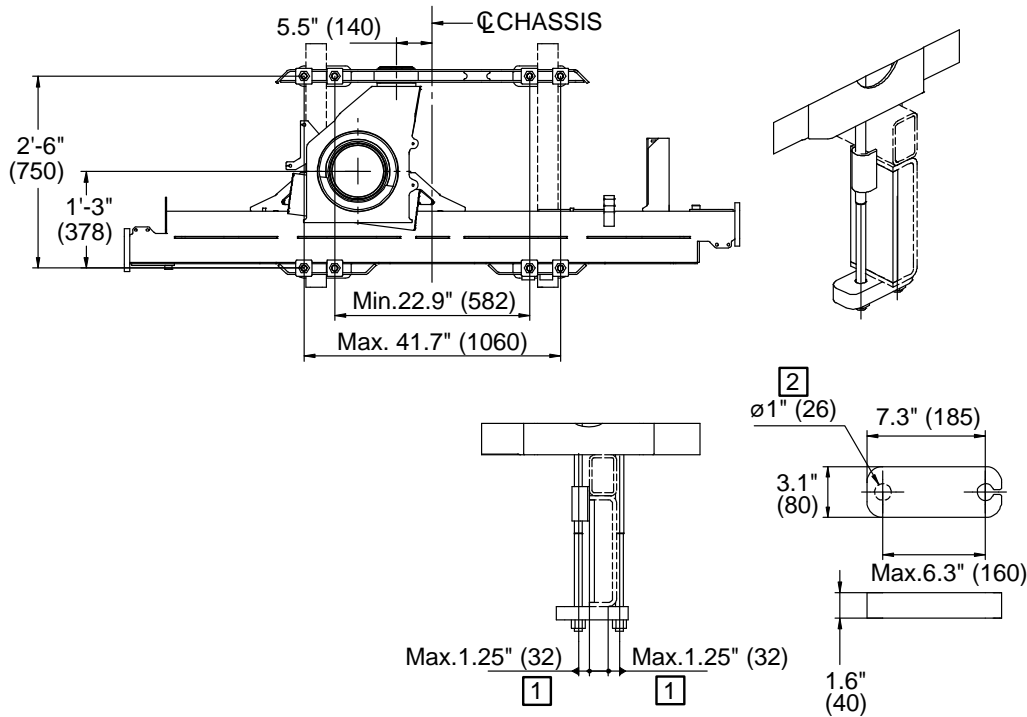

MOUNTING KIT 3 x M33x2 BOLTS + 1 M30x2 BOLT

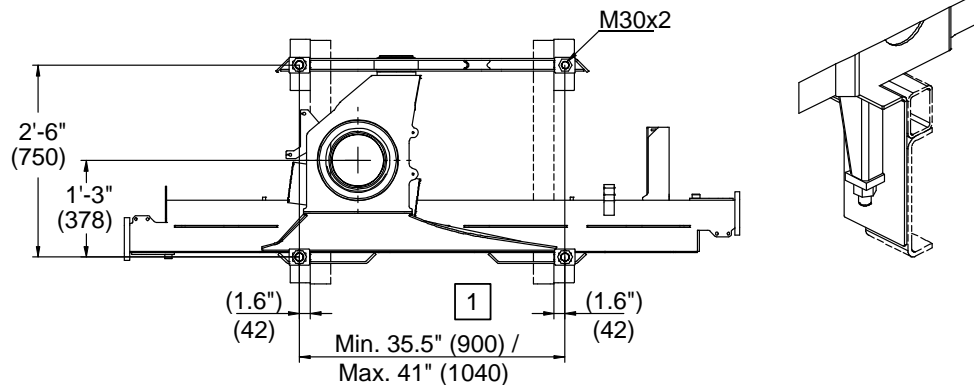

NOTES (SEE REFERENCE NUMBER IN BOX):

- 1 VALUES DICTATED BY STRENGTH CONSIDERATIONS.
- 2 DRILL HOLE WHEN ASSEMBLING.
- 3 SEE INSTALLATION MANUAL # 99901230 REGARDING INSTALLATION.
- 4 MOUNTING KIT AND REPLACEMENT PART NUMBERS ARE IN THE CRANE PARTS MANUALS.

20/138DL Swing Clearance

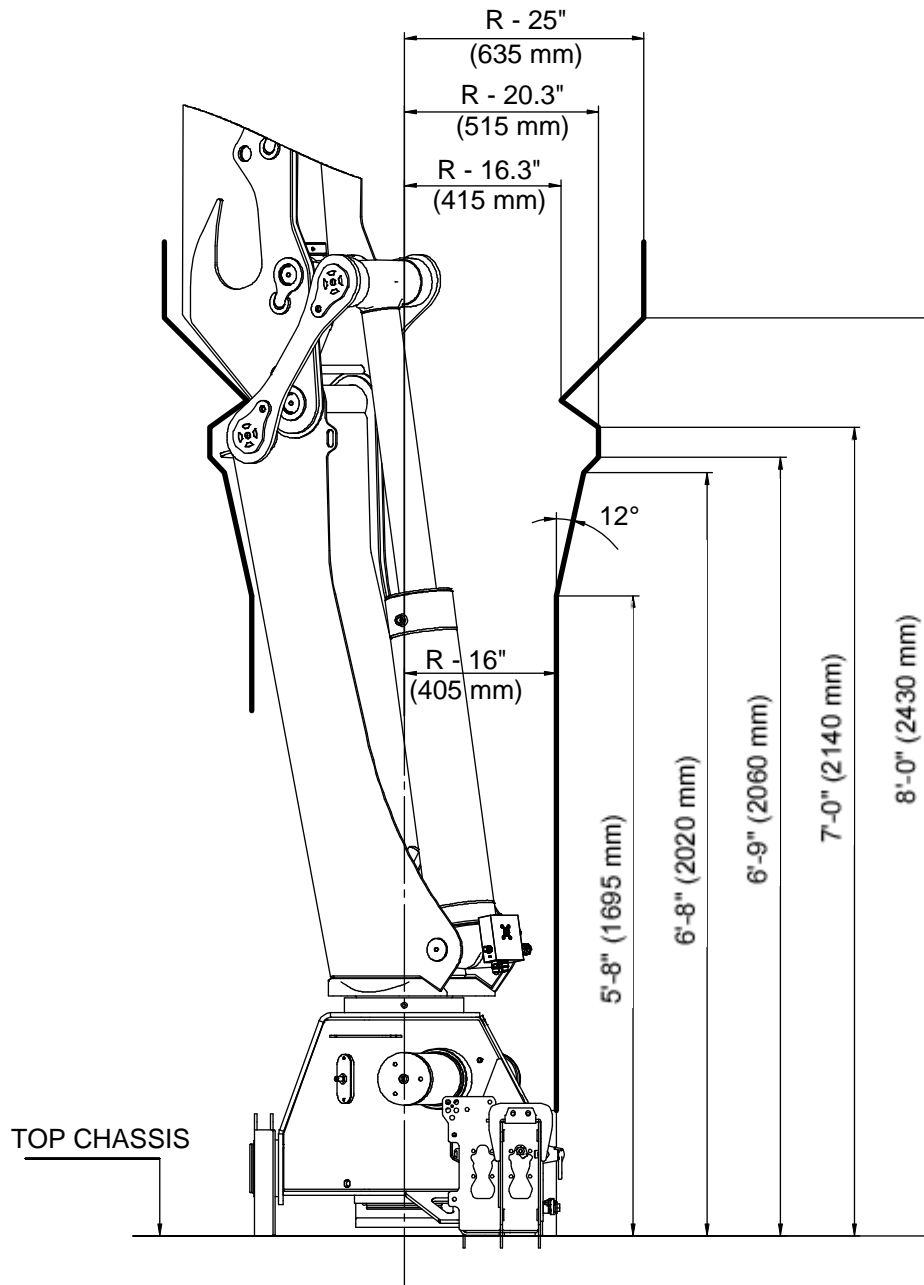

CHAPTER 2

Hydraulic Schematics

In This Chapter

Hydraulic Diagram - 20/138DL Danfoss 6-Function Radio	24
Hydraulic Diagram - 20/138DL Danfoss 7-Function Radio	25
Hydraulic Diagram - 20/138DL Hydrocontrol 6-Function Manual	26
Hydraulic Diagram - 20/138DL Hydrocontrol 6-Function Radio	27

Hydraulic Diagram - 20/138DL Danfoss 6-Function Radio

This diagram applies to a 20/138DL crane with a single-circuit fixed pump, and 6-function Danfoss radio controls.

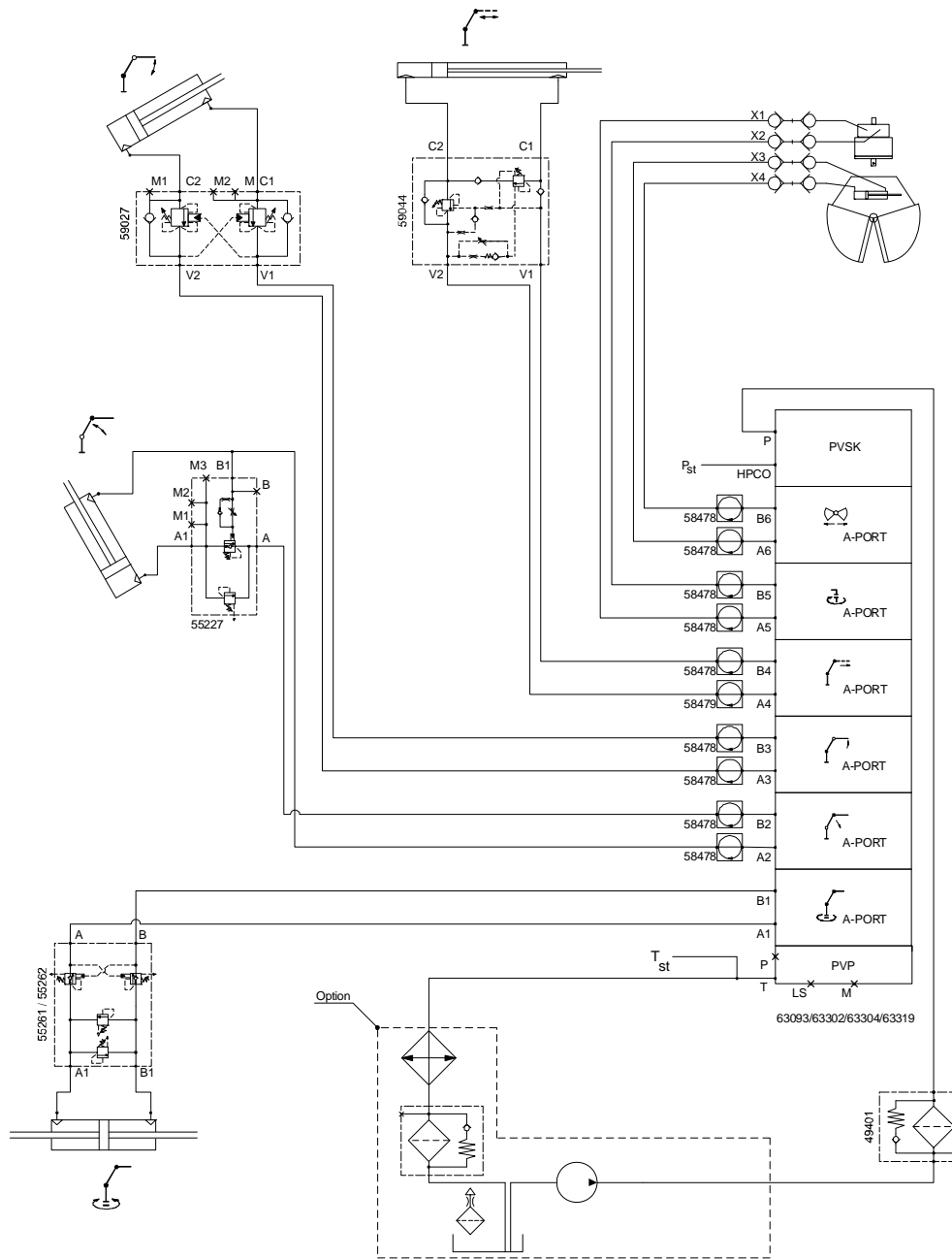

Hydraulic Diagram - 20/138DL Danfoss 7-Function Radio

This diagram applies to a 20/138DL crane with a single-circuit fixed pump, and 7-function Danfoss radio controls.

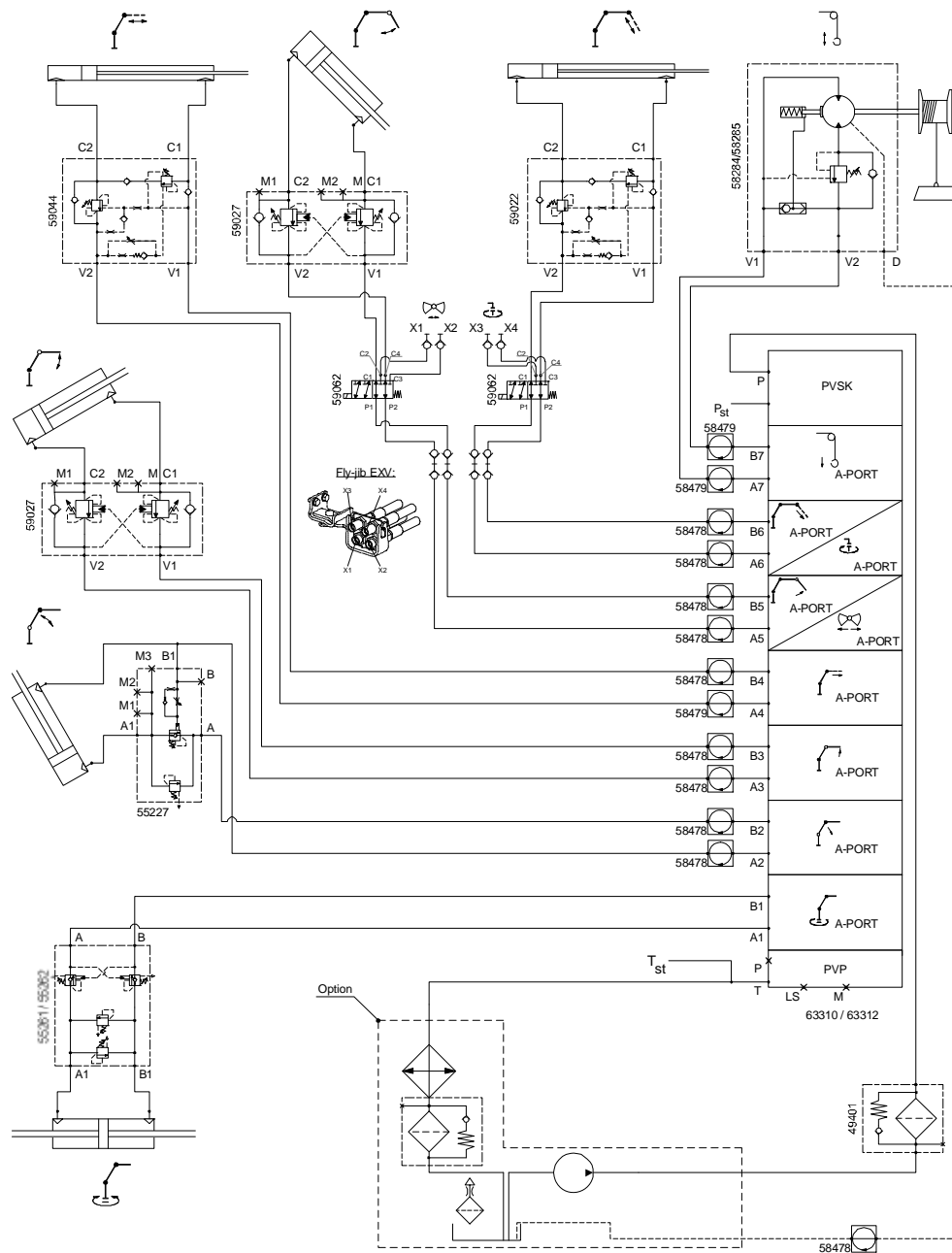

Hydraulic Diagram - 20/138DL Hydrocontrol 6-Function Manual

This diagram applies to a 20/138DL crane with a single-circuit fixed pump, and 6-function Hydrocontrol manual controls.

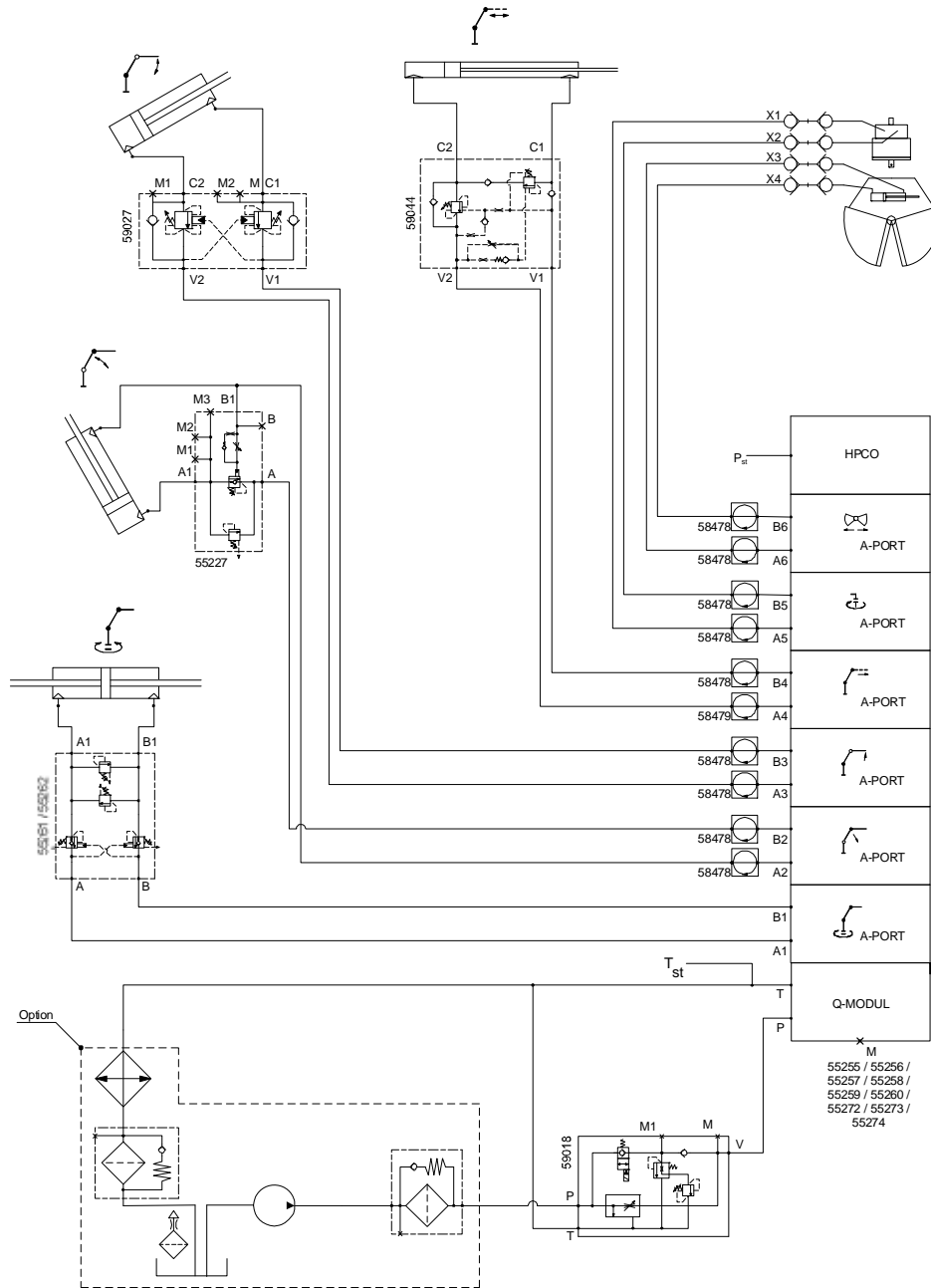

Hydraulic Diagram - 20/138DL Hydrocontrol 6-Function Radio

This diagram applies to a 20/138DL crane with a single-circuit fixed pump, and 6-function Hydrocontrol radio controls.

