



**Parts Manual
OTR Bodies - Steel**

IOWA MOLD TOOLING CO., INC.
BOX 189, GARNER, IA 50438-0189
515-923-3711
PRODUCT SUPPORT FAX: 515-923-3674

MANUAL PART NUMBER 99900329
LAST REVISED: 04-06-95

PARTS ORDERING INFORMATION

Before placing an order, make certain the following information is recorded.

This information should then be given to an IMT representative when placing your order.

BODY MODEL NUMBER	
BODY SERIAL NUMBER	
DATE OF PURCHASE	

To more efficiently process your order, the following information determined in advance will be appreciated.

PART NUMBER, DESCRIPTION AND QUANTITY OF PARTS REQUIRED.

IF LEFT OR RIGHT SIDE IS APPLICABLE, PLEASE SPECIFY.

PLEASE, CONTACT IMT AT THE FOLLOWING ADDRESS:

IOWA MOLD TOOLING CO., INC.
BOX 189
GARNER, IOWA 50438-0189
TELEPHONE: 515-923-3711
PRODUCT SUPPORT FAX: 515-923-2424

or

IMT CRANES CANADA, LTD.
385 WEST STREET SOUTH
ORILLIA, ONTARIO, L3V 5H2, CANADA
TELEPHONE: 703-325-7458
FAX: 705-325-7624

TABLE OF CONTENTS

SECTION 1.	INSTALLATION AND SPECIFICATIONS
SECTION 2.	UNDERBODY COMPARTMENTS
SECTION 3.	HOSE REEL COMPARTMENTS
SECTION 4.	AIR SYSTEM OPTIONS
SECTION 5.	ELECTRICAL OPTIONS
SECTION 6.	MISCELLANEOUS OPTIONS
SECTION 7.	SAFETY EQUIPMENT

Section 1. INSTALLATION AND SPECIFICATIONS

MODEL 95 BASIC BODIES - STEEL

		1/8" DECK PLATE	1/4" DECK PLATE	HEAVY DUTY WITH STAKE POCKETS
SINGLE AXLE	14' 120" CA	52707416 1912 LBS	52707266 2440 LBS	51708126 2624 LBS
	15" 138" CA	52707417 1914 LBS	52707267 2481 LBS	51708127 2678 LBS
	16' 144" CA	52707418 2044 LBS	52707268 2651 LBS	51708128 2855 LBS
	16' 152" CA	52707418 2044 LBS	52707268 2651 LBS	51708128 2855 LBS
	16' 156" CA	52707418 2044 LBS	52707268 2651 LBS	51708128 2855 LBS
	17' 156" CA	52707419 2175 LBS	52707269 2820 LBS	51708129 3034 LBS
TANDEM AXLE	18' 144" CT	52707420 2307 LBS	52707270 2991 LBS	51708130 3215 LBS
	18' 156" CT	52707420 2307 LBS	52707270 2991 LBS	51708130 3215 LBS

CA = CAB TO AXLE DIMENSION
 CT = CAB TO TRUNNION DIMENSION

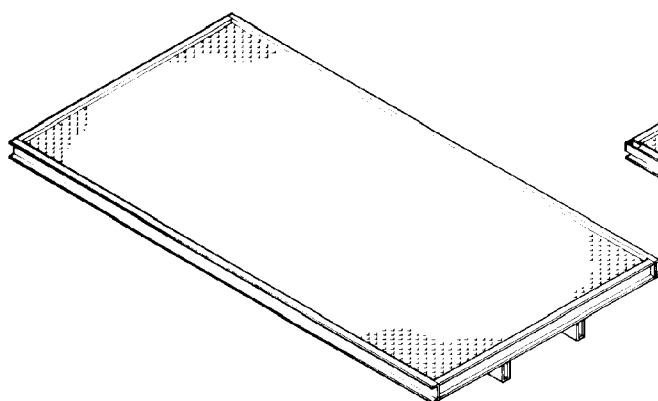

OTR BODY (1/8" OR 1/4" DECKPLATE)

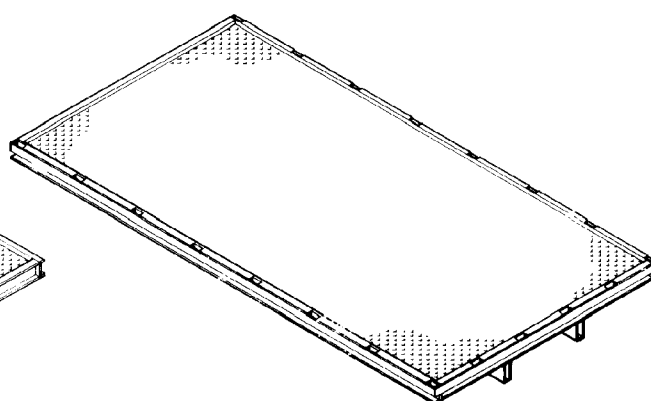

OTR BODY (HD /STAKE POCKETS)

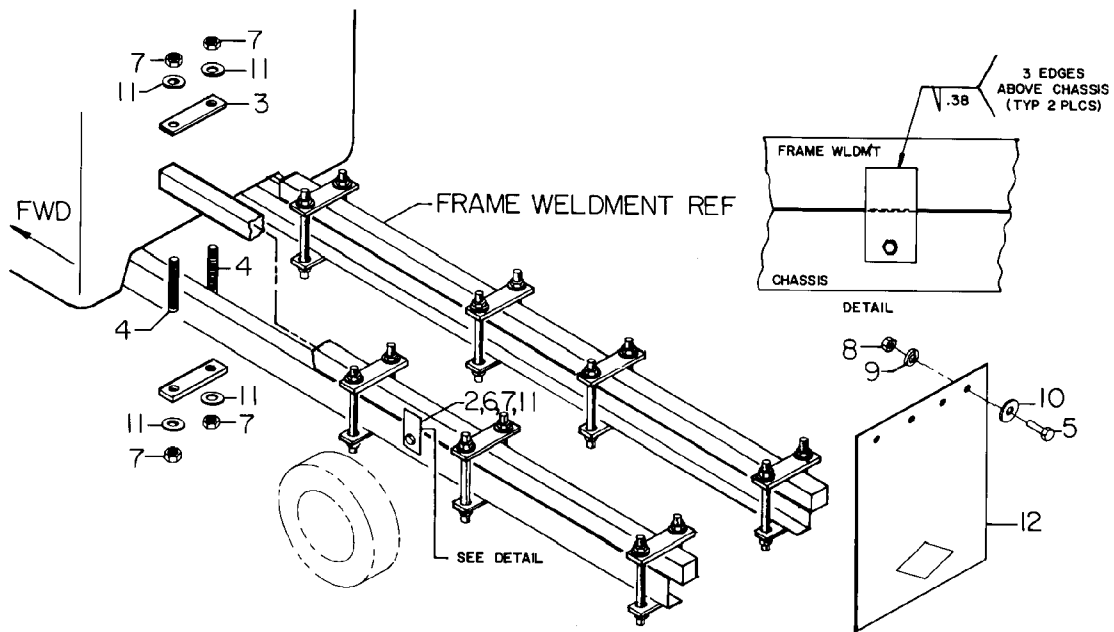

**INSTALLATION KIT (STEEL OTR BODY)
PART NUMBER 93707567**

2.	60105107	REINFORCEMENT PLATE	2
3.	60105958	CLAMP PLATE	16
4.	60109298	ROD 5/8-11 X 22 1/2	16
5.	72060025	CAP SCREW 5/16-18 X 1 HH GR5	8
6.	72060151	CAP SCREW 5/8-11 X 2 HH GR5	2
7.	72062091	NUT 5/8-11 LOCK	34
8.	72062109	NUT 5/16-18 LOCK	8
9.	72063050	WASHER 5/16 LOCK	8
10.	72063078	WASHER 5/16 X 1 5/8 OD	8
11.	72063119	WASHER 5/8 WRT	34
12.	76039117	MUD FLAP	2

Section 2. UNDERBODY COMPARTMENTS

UNDERBODY TOOLBOXES WITH SLIDE-TOP DOORS

LENGTH CA / CT	LOCATION								DIMENSIONS			ASSEMBLIES	
	14'	15'	16'	16'	16'	17'	18'	18'	H	L	D	UBTB ASM	DOOR ASM
	█	█	█	█	█	█	█	█	24	52	26	53001001	53000602
			█	█	█	█			24	37	21	53001002	53000603
	█	█	█	█	█	█	█	█	24	34	21	53001003	53000600
	█	█	█	█	█			█	24	19	21	53001013	53000611
	█	█	█	█	█	█	█	█	21 3/8	26	21	51707531	51707561

NOTE: COMPARTMENT ASSEMBLIES ARE NOT A NORMAL REPLACEMENT ITEM.
THE PART NUMBER IS LISTED AS REFERENCE ONLY.

LOCATION KEY:

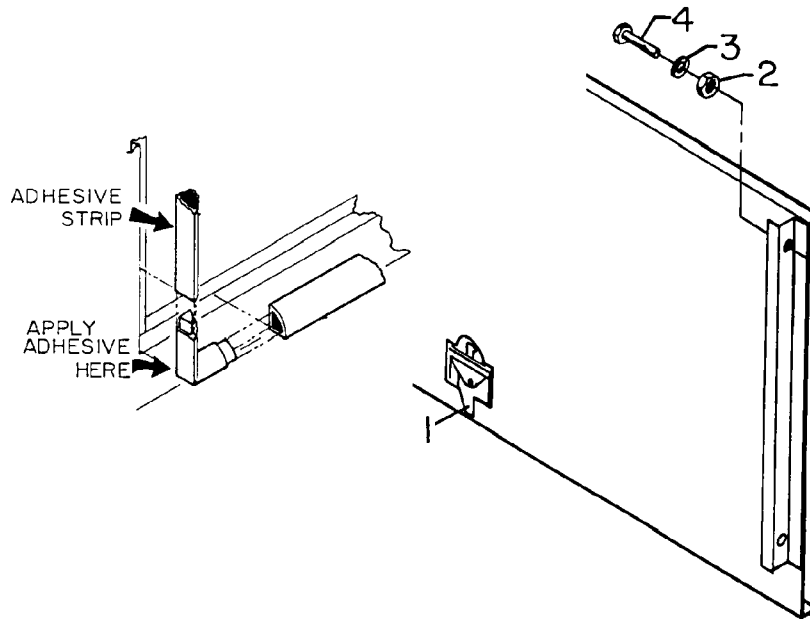

COMMON PARTS USED ON ALL SLIDE-TOP DOORS

- | | | |
|-------------|--|-----|
| 1. 72066394 | LATCH (WELD ON) | 1 |
| 2. 72062004 | NUT 1/2-13 LOCK | 2 |
| 3. 72063051 | WASHER 3/8 LOCK | 2 |
| 4. 72601377 | MACH SCREW 3/8-16 X 2 HH | 2 |
| 5. 70392639 | WEATHERSTRIP CORNER | 2 |
| 6. 89392588 | WEATHERSTRIP W/ADHESIVE (SPECIFY LENGTH) | REF |
| 7. 70067005 | ADHESIVE - TUBE | REF |

NOTE: WEATHERSTRIP ADHESIVE BACKING MUST BE APPLIED SO THAT DOOR COMPRESSES RATHER THAN SHEARS THE ADHESIVE STRIP. THE WEATHERSTRIP CORNERS ARE NOT ADHESIVE BACKED. AN APPROPRIATE ADHESIVE MUST BE USED.

UNDERBODY TOOLBOXES WITH SWING-STYLE DOORS

LENGTH CA / CT	LOCATION								DIMENSIONS			ASSEMBLIES	
	14' 120	15' 138	16' 144	16' 152	16' 156	17' 156	18' 144	18' 156	H	L	D	UBTB ASM	DOOR ASM
		■	■	■	■	■	■	■	24	37	21	53000804	53000113
	■	■	■	■	■	■	■		24	37	21	53000905	53000113
								■	24	34	21	53000926	53000121
								■	24	34	21	51708829	53000121

NOTE: COMPARTMENT ASSEMBLIES ARE NOT A NORMAL REPLACEMENT ITEM. THE PART NUMBER IS LISTED AS REFERENCE ONLY.

LOCATION KEY:

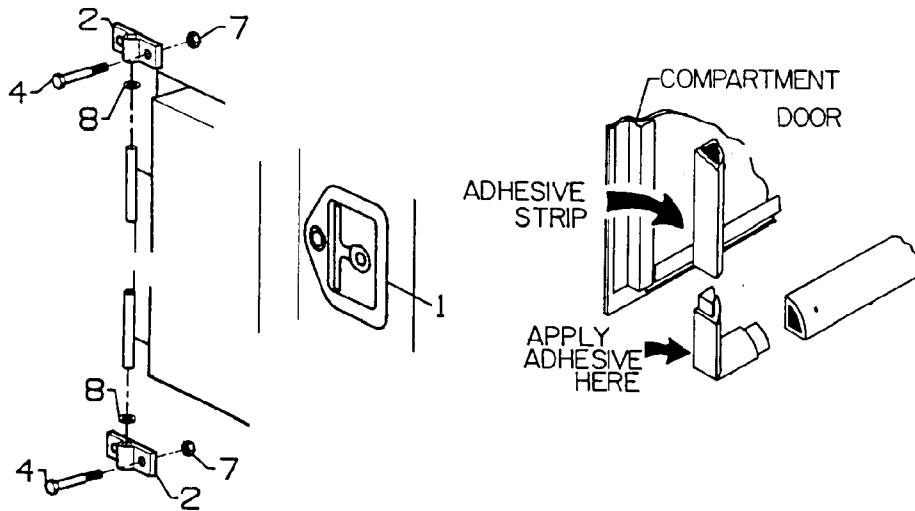

COMMON PARTS USED ON ALL SWING-STYLE DOORS

1.	72066394	LATCH (WELD ON)	1
2.	60020054	HINGE - 2 HOLE BRASS	2
3.	70391615	RUBBER BUMPER	1
4.	72060025	CAP SCREW 5/16-18 X 1 HH GR5	4
5.	72060652	MACH SCREW 1/4-20 X 1 1/2 RDH	1
6.	72062104	NUT 1/4-20 LOCK	1
7.	72062109	NUT 5/16-18 LOCK	4
8.	72063076	WEAR WASHER 3/8 X 5/8	1
9.	70392639	WEATHER STRIP CORNER	4
10.	89392588	WEATHERSTRIP W/ADHESIVE (SPECIFY LENGTH)	
11.	70067005	ADHESIVE - TUBE	REF

NOTE: WEATHERSTRIP ADHESIVE BACKING MUST BE APPLIED SO THAT DOOR COMPRESSES RATHER THAN SHEARS THE ADHESIVE STRIP. THE WEATHERSTRIP CORNERS ARE NOT ADHESIVE BACKED. AN APPROPRIATE ADHESIVE MUST BE USED.

UNDERBODY COMPRESSOR COMPARTMENTS

LENGTH CA / CT	LOCATION								LENGTH (COMPRSR TYPE)	ASSEMBLIES	
	14'	15'	16'	16'	16'	17'	18'	18'		COMP. ASM	DOOR W/LATCH
	120	138	144	152	156	156	144	156	52" (HYD)	51706072	52706070
									34" (PTO)	51707242	52707243

NOTE: COMPARTMENT ASSEMBLIES ARE NOT A NORMAL REPLACEMENT ITEM. THE PART NUMBER IS LISTED AS REFERENCE ONLY.

LOCATION KEY:

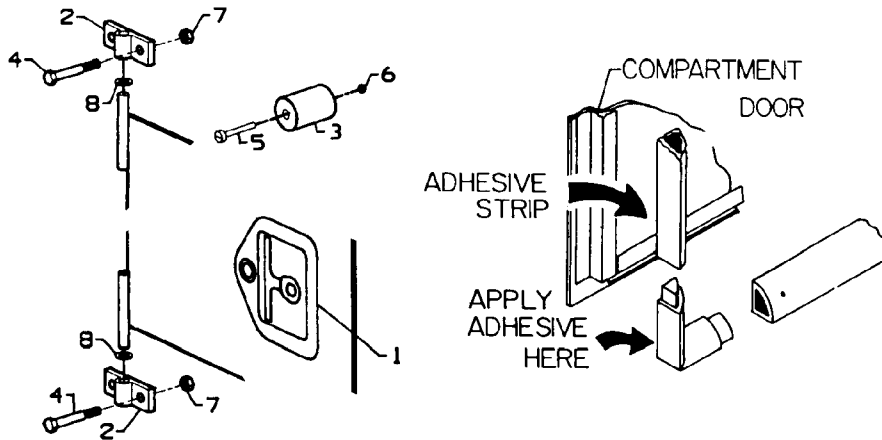

COMMON PARTS USED ON COMPRESSOR COMPARTMENT DOORS

1.	72066394	LATCH (WELD ON)	1
2.	60020054	HINGE - 2 HOLE BRASS	2
4.	72060025	CAP SCREW 5/16-18 X 1 HH GR5	4
7.	72062109	NUT 5/16-18 LOCK	4
8.	72063076	WEAR WASHER 3/8 X 5/8	1
9.	70392639	WEATHER STRIP CORNER	4
10.	89392588	WEATHERSTRIP W/ADHESIVE (SPECIFY LENGTH)	
11.	70067005	ADHESIVE - TUBE	REF

NOTE: WEATHERSTRIP ADHESIVE BACKING MUST BE APPLIED SO THAT DOOR COMPRESSES RATHER THAN SHEARS THE ADHESIVE STRIP. THE WEATHERSTRIP CORNERS ARE NOT ADHESIVE BACKED. AN APPROPRIATE ADHESIVE MUST BE USED.

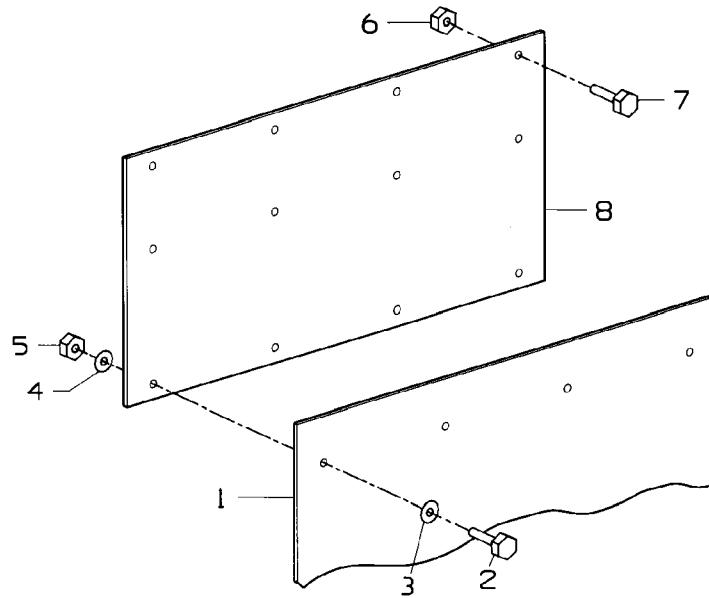

**MUD FLAP EXTENSION KIT
PART NUMBER 51709770**

1.	76039117	MUD FLAP	2REF
2.	72060025	CAP SCR 5/16-18X1 HHGR5	8REF
3.	72063078	WASHER 5/16X1-5/8 OD	8REF
4.	72063050	WASHER 5/16 LOCK	8REF
5.	72062109	NUT 5/16-18 LOCK	8REF
6.	72062109	NUT 5/16-18 LOCK	8
7.	72060025	CAP SCR 5/16-18X1 HHGR5	8
8.	60113965	EXTENSION PLATE	2

Section 3. HOSE REEL COMPARTMENTS

HOSE REEL COMPARTMENTS

- A. 516 CRANE
 - B. 1216 CRANE
 - C. 516 CRANE WITH DOOR
 - D. 1216 CRANE WITH DOOR
1. 52707322 HOSE REEL COMPARTMENT
 2. 60103343 ANGLE
 3. 72060062 CAP SCREW 7/16-14 X 1 HHGR5
 4. 72062003 NUT 7/16-14 HEX
 5. 72063004 WASHER 7/16 WRT
 6. 72060023 CAP SCR 5/16-18 X 3/4 HHGR5
 - 72060047 CAP SCR 3/8-16 X 3/4 HHGR5
 - 72060026 CAP SCR 5/16-18 X 1 1/4 HHGR5
 7. 72063002 WASHER 5/16 WRT
 - 72063003 WASHER 3/8 WRT
 8. 72062109 NUT 5/16-18 LOCK
 - 72062103 NUT 3/8-16 LOCK
 9. 72060026 CAP SCR 5/16-18 X 1 1/4 HHGR5
 10. 72062109 NUT 5/16-18 LOCK
 11. 72063002 WASHER 5/16 WRT
 12. 51709149 FOLD DOWN DOOR (SEE DWG)
 13. 60112995 BRACKET

	51708936	51707324	51708935	51708934
	A	B	C	D
1	1	1	1	1
2	1	1	1	1
3	1	1	1	1
4	1	1	1	1
5	1	1	1	1
6	3		3	
7		3		3
8	3		3	3
9		3		3
10		3		3
11		3		3
12			1	1
13		1		1

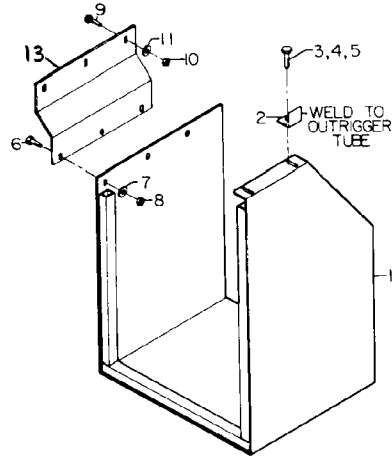

HOSE REEL COMPARTMENT DOOR PART NUMBER 51709149

1. 52709148 DOOR WELDMENT 1
2. 60113262 DOOR BOTTOM 1
3. 60113263 SOCKET MOUNTING BRACKET 2
4. 70143568 HANDLE 1
5. 70392190 RUBBER BUMPER 2
6. 72060651 MACH SCREW 1/4-20 X 1 1/4 RD HD 4
7. 72062104 NUT 1/4-20 LOCK 25
8. 72063001 WASHER 1/4 WRT 25
9. 72066376 PLUNGER/SOCKET 2
10. 72601164 CARRIAGE BOLT 1/4-20 X 1 1/4 GR2 5
11. 72601508 CAP SCREW 1/4-20 X 1 BTN HD 12

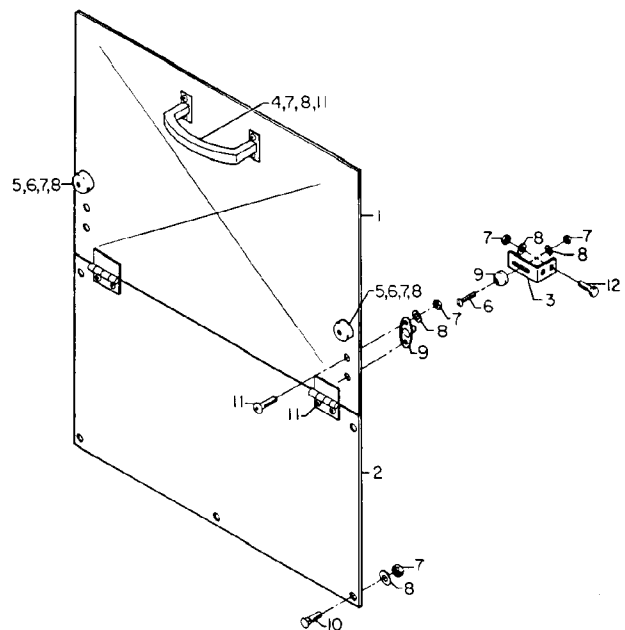

Section 4. AIR SYSTEM OPTIONS

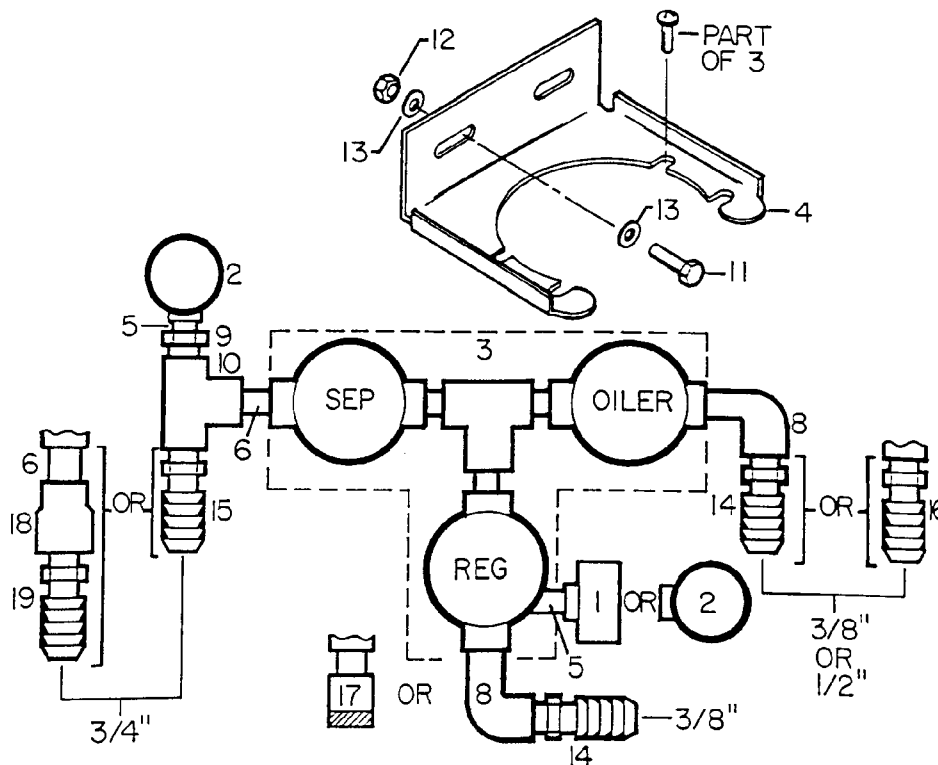

MOISTURE SEPARATOR/REGULATOR/OILER ASSEMBLIES
3/8" HOSE REEL PART NUMBER 51706341
1/2" HOSE REEL PART NUMBER 51706342
3/8" & 1/2" HOSE REEL PART NUMBER 51706343

NOTE: EACH INSTALLATION MAY VARY, USE THE PARTS LIST AND THE DRAWING AS A GUIDE ONLY.

- | | | |
|-----|----------|---|
| 1. | 70048015 | AIR PRESSURE GAUGE - 300 PSI REAR MOUNT |
| 2. | 70048036 | AIR PRESSURE GAUGE - 300 PSI SIDE MOUNT |
| 3. | 70073439 | SEP / REG / OILER ASSEMBLY |
| 4. | 70141473 | MOUNTING BRACKET |
| 5. | 72053013 | PIPE NIPPLE - 1/4 X CLOSE |
| 6. | 72053090 | PIPE NIPPLE - 1/2 X CLOSE |
| 7. | 72053243 | PIPE PLUG - 1/2 HOL HEX |
| 8. | 72053284 | STREET ELBOW - 1/2 X 90 DEG |
| 9. | 72053374 | REDUCER BUSHING - 1/2 X 1/4 |
| 10. | 72053603 | TEE - 1/2 |
| 11. | 72060004 | CAP SCREW 1/4-20 X 1 HH GR5 |
| 12. | 72062104 | NUT 1/4-20 LOCK |
| 13. | 72063001 | WASHER 1/4 WRT |
| 14. | 72531541 | BARBED NIPPLE - 1/2 MPT X 3/8 BARB |
| 15. | 72531547 | BARBED NIPPLE - 1/2 MPT X 3/4 BARB |
| 16. | 72053457 | BARBED NIPPLE - 1/2 MPT X 1/2 BARB |
| 17. | 72532281 | QUICK COUPLER - 1/4 |
| 18. | 72053435 | REDUCER COUPLING - 3/4 X 1/2 |
| 19. | 72053458 | BARBED NIPPLE - 3/4 MPT X 3/4 BARB |

**HOSE REEL KIT - 3/8" X 35' HOSE
PART NUMBER 51706348**

- | | | | |
|-----|----------|-----------------------------|-----|
| 1. | 70073625 | HOSE REEL | 1 |
| 2. | 72053283 | STREET ELBOW 3/8NPT 90° | 1 |
| 3. | 72060025 | CAP SCREW 5/16-18X1 HHGR5 | 4 |
| 4. | 72062109 | NUT 5/16-18 LOCK | 4 |
| 5. | 72063002 | WASHER 5/16 WRT | 8 |
| 6. | 72066061 | HOSE CLAMP | 2 |
| 7. | 72531543 | BARBED NIPPLE 3/8MPT 1/2 | 1 |
| 8. | 72532021 | QUICK DISCONNECT 1/4 FPT | 1 |
| 9. | 72532038 | NIPPLE - DISCONNECT 1/4 FPT | 1 |
| 10. | 89039176 | AIR HOSE 1/2 250# | 36" |

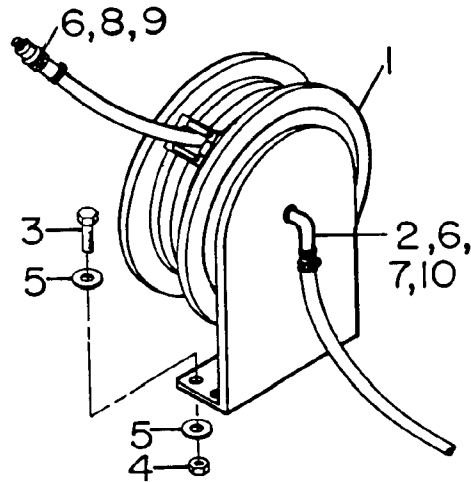

**HOSE REEL KIT - 1/2 X 50' HOSE
PART NUMBER 51706347**

- | | | | |
|----|----------|--------------------------|-----|
| 1. | 70732096 | HOSE REEL | 1 |
| 2. | 72053284 | STREET ELBOW 1/2NPT 90° | 1 |
| 3. | 72053810 | PIPE CAP 1/2 | 1 |
| 4. | 72060046 | CAP SCR 3/8-16X1 HHGR5 | 4 |
| 5. | 72062103 | NUT 3/8-16 LOCK | 4 |
| 6. | 72063003 | WASHER 3/8 WRT | 8 |
| 7. | 72066000 | HOSE CLAMP | 2 |
| 8. | 72051547 | BARBED NIPPLE 1/2MPT 3/4 | 2 |
| 9. | 89392349 | HOSE 3/4 300# | 36" |

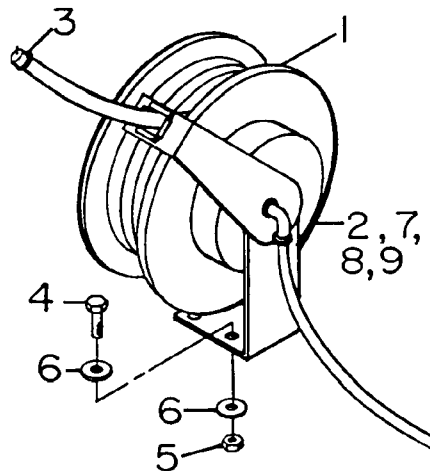

AIR TANK KIT - DUAL 15 GALLON - UNDER FRAME
PART NUMBER 51709693

- | | | | |
|-----|----------|------------------------------|----|
| 1. | 52709697 | MTG BRACKET | 2 |
| 2. | 60106492 | TANK BRACKET | 4 |
| 3. | 72060048 | CAP SCR 3/8-16X1-1/2 HHGR5 | 8 |
| 4. | 72060096 | CAP SCR 1/2-13X2-1/2 HHGR5 | 8 |
| 5. | 72062080 | NUT 1/2-13 LOCK | 8 |
| 6. | 72062103 | NUT 3/8-16 LOCK | 8 |
| 7. | 72063005 | WASHER 1/2 WRT | 16 |
| 8. | 70073062 | TANK-15 GALLON | 2 |
| 9. | 89392349 | HOSE 3/4 200PSI | 8' |
| 10. | 72532559 | HOSE FITTING 3/4NPT 3/4HOSE | 4 |
| 11. | 72053556 | STREET ELBOW 3/4NPT 90° | 4 |
| 12. | 72053180 | REDUCER BUSHING 1-1/4X3/4NPT | 4 |
| 13. | 72053397 | PIPE PLUG 1-1/4 HOL HEX | 4 |
| 14. | 72053246 | PIPE PLUG 3/8 SQHD | 1 |
| 15. | 73054032 | SAFETY VALVE 200 PSI 1/4 | 1 |
| 16. | 72053282 | STREET ELBOW 1/4NPT 90° | 1 |
| 17. | 72066000 | HOSE CLAMP 1/2 - 1-1/4 | 2 |
| 18. | 51709358 | DRAIN ASSEMBLY | 1 |
| 19. | 72053372 | REDUCE BUSHING 3/8-1/4NPT | 1 |
| 20. | 71393886 | DECAL-DANGER AIR TANK | 1 |
- PLACE ITEM 20 NEAR DRAIN VALVE AND IN CLEAR VIEW OF OPERATOR

NOTE: NOT USED ON 3/4 & 1-TON CHASSIS.

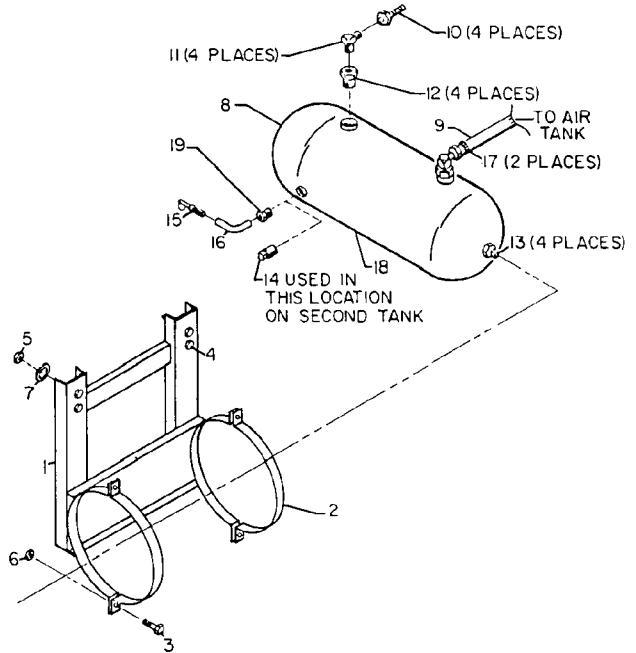

AIR TANK KIT - 22 1/2 GALLON
PART NUMBER 51706697

- | | | | |
|-----|----------|------------------------------|----|
| 1. | 60113718 | SLEEVE | 2 |
| 2. | 70131788 | AIR TANK 22-1/2 GALLON | 1 |
| 3. | 72053517 | ADAPTER 1/4MPT 1/4MPT HEX | 1 |
| 4. | 72531836 | REDUCER BUSHING 1 1/4-3/4NPT | 2 |
| 5. | 72532552 | HOSE FTG 1/4 1/4 BRS | 1 |
| 6. | 72053556 | STREET ELBOW 3/4NPT 90° | 2 |
| 7. | 72053610 | TEE 1/4NPT | 1 |
| 8. | 72053458 | BARB NIPPLE 3/4MPT 3/4HOSE | 1 |
| 9. | 73054032 | SAFETY VALVE 1/4NPT 200PSI | 1 |
| 10. | 51709358 | DRAIN ASM (SEE DWG) | 1 |
| 11. | 72060092 | CAP SCR 1/2-13X1-1/4 HHGR5 | 8 |
| 12. | 72063005 | WASHER 1/2 WRT | 16 |
| 13. | 72062080 | NUT 1/2-13 LOCK | 8 |
| 14. | 60113718 | SPACER BRACKET | 2 |
| 15. | 71393886 | DECAL-DANGER AIR TANK | 1 |
- PLACE ITEM 15 NEAR DRAIN VALVE AND IN CLEAR VIEW OF OPERATOR

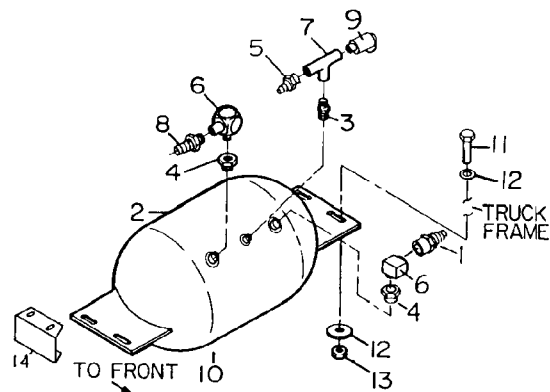

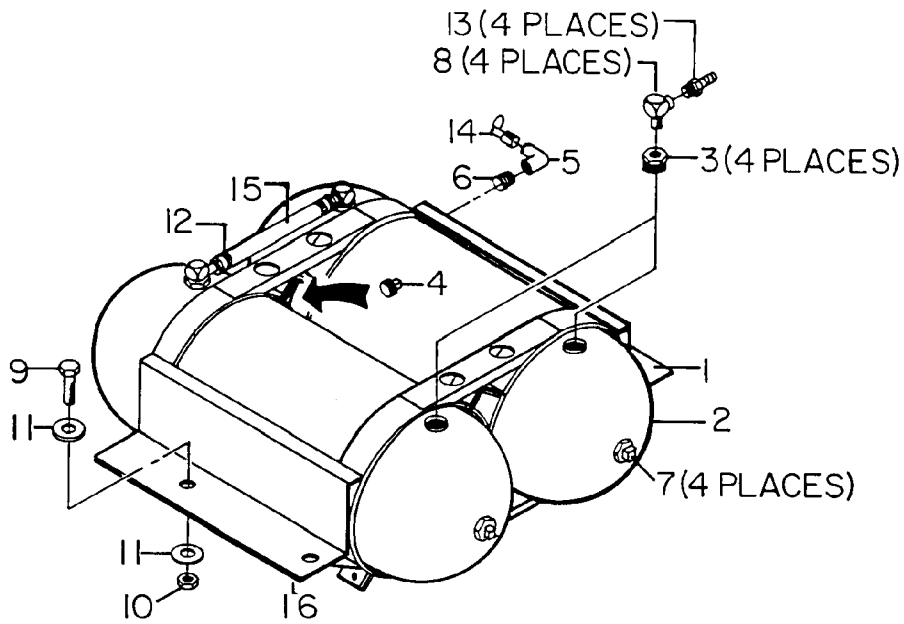

**AIR TANK KIT - DUAL 15 GALLON
PART NUMBER 51707363**

1.	51705045	TANK BRACKET	1
2.	70073062	AIR TANK - 15 GAL	2
3.	72053180	REDUCER BUSHING 1 1/4 - 3/4	4
4.	72053246	PIPE PLUG - 3/8 SQ HD	1
5.	72053282	STREET ELBOW 1/4 X 90 DEG	1
6.	72053372	REDUCER BUSHING 3/8 - 1/4	1
7.	72053397	PIPE PLUG - 1 1/4 HOL HEX	4
8.	72053556	STREET ELBOW 3/4 X 90 DEG	4
9.	72060048	CAP SCREW 3/8-16 X 1 1/2 HH GR5	4
10.	72062103	NUT 3/8-16 LOCK	4
11.	72063003	WASHER 3/8 WRT	8
12.	72066000	HOSE CLAMP 1/2 - 1 1/4	2
13.	72532559	HOSE FITTING 3/4 3/4 BRS	4
14.	73054032	SAFETY VALVE 1/4 200 PSI	1
15.	89392349	HOSE - 3/4 200 PSI X 7	1
16.	51709358	DRAIN ASM (SEE DWG)	1
17.	71393886	DECAL-DANGER AIR TANK	1

PLACE ITEM 17 NEAR DRAIN VALVE AND IN CLEAR VIEW OF OPERATOR

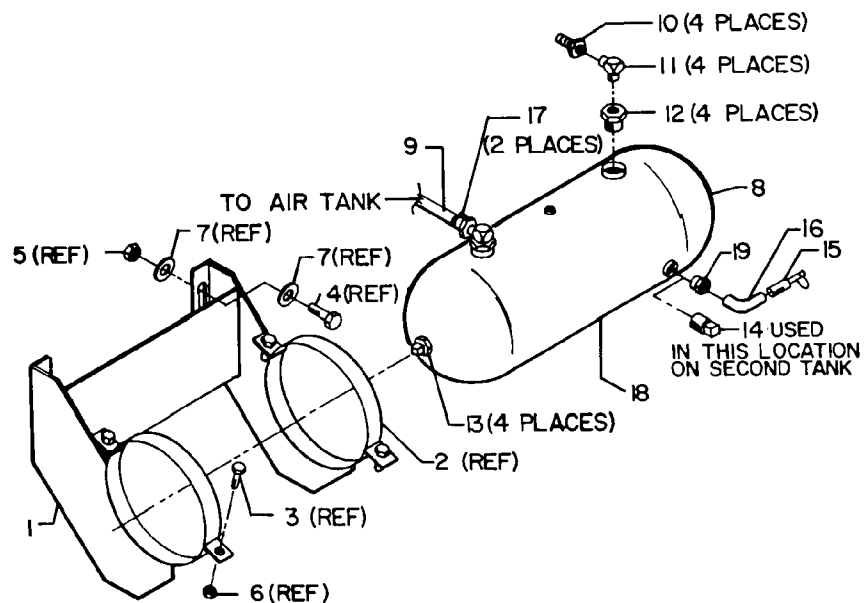

**AIR TANK KIT - DUAL 15 GALLON (OUTSIDE FRAME)
PART NUMBER 51706351**

1.	51705427	TANK BRACKET (INCL: 2 - 7)	2
2.	60106492	BRACKET (PART OF 1)	4 REF
3.	72060048	CAP SCREW 3/8-16 X 1 1/2 HH GR5	8 REF
4.	72060096	CAP SCREW 1/2-13 X 2 1/2 HH GR5	8 REF
5.	72062080	NUT 1/2-13 LOCK (PART OF 1)	8 REF
6.	72062103	NUT 3/8-16 LOCK (PART OF 1)	8 REF
7.	72063005	WASHER 1/2 WRT (PART OF 1)	16 REF
8.	70073062	AIR TANK	2
9.	89392349	HOSE - 3/4 200 PSI X 8 FT	1
10.	72532559	HOSE FITTING 3/4 3/4 BRASS	4
11.	72053556	STREET ELBOW 3/4 X 90 DEG	4
12.	72053180	REDUCER BUSHING 1 1/4 X 3/4	4
13.	72053397	PIPE PLUG 1 1/4 HOL HEX	4
14.	72053246	PIPE PLUG 3/8 SQ HD	1
15.	73054032	SAFETY VALVE 1/4 200 PSI	1
16.	72053282	STREET ELBOW 1/4 X 90 DEG	1
17.	72066000	HOSE CLAMP 1/2 - 1 1/4	2
18.	51709358	DRAIN ASM (SEE DWG)	1
19.	72053372	REDUCER BUSHING 3/8 X 1/4	1
20.	71393886	DECAL-DANGER AIR TANK	1

PLACE ITEM 20 NEAR DRAIN VALVE AND IN CLEAR VIEW OF OPERATOR

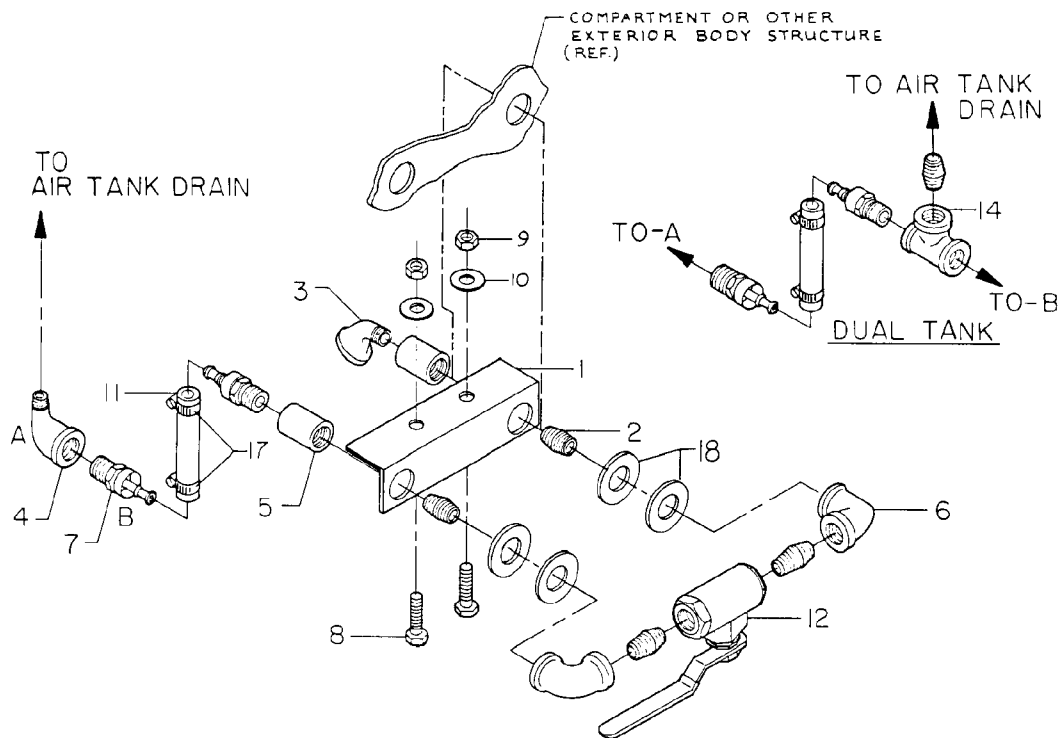

**AIR TANK DRAIN ASSEMBLY
51709358**

ITEM	PART NO.	DESCRIPTION	QTY
1.	60116097	MOUNTING BRACKET	1
2.	72053141	PIPE NIPPLE 3/4NPT X CLOSE	5
3.	72053173	STREET ELBOW 3/4NPT 45°	1
4.	72053285	STREET ELBOW 3/4NPT 90°	1
5.	72053305	COUPLING 3/4NPT	2
6.	72053325	ELBOW 3/4NPT 90°	2
7.	72053458	BARBED NIPPLE 3/4 MPT 3/4	3
8.	72060025	CAP SCREW 5/16-18X1 HH GR5	2
9.	72062109	NUT 5/16-18 LOCK	2
10.	72063002	WASHER 5/16 WRT	2
11.	89392349	HOSE 3/4 300 PSI X 120"	1
12.	73054626	BALL VALVE 3/4NPT	1
13.	70391601	DECAL-AIR TANK DRAIN	1
14.	72053604	TEE 3/4	1
15.	72066340	POP RIVET 1/8X3/8 GRIP ALUM.	1
16.	72066525	HOSE CLAMP 3/4 VINYL	1
17.	72066000	HOSE CLAMP #12	2
18.	72063066	WASHER 1" FLAT (AS NEEDED)	8

NOTE: INSTALLATION MAY VARY DUE TO APPLICATION.
THIS ASSEMBLY IS PART OF MOST AIR TANK KITS.

**COVER KIT - SEPARATOR / REGULATOR / OILER
PART NUMBER 51707491**

1.	60111136	COVER	1
2.	60111137	BRACE	2
3.	72060025	CAP SCREW 5/16-18 X 1 HH GR5	7
4.	72062109	NUT 5/16-18 LOCK	7
5.	72063002	WASHER 5/16 WRT	7

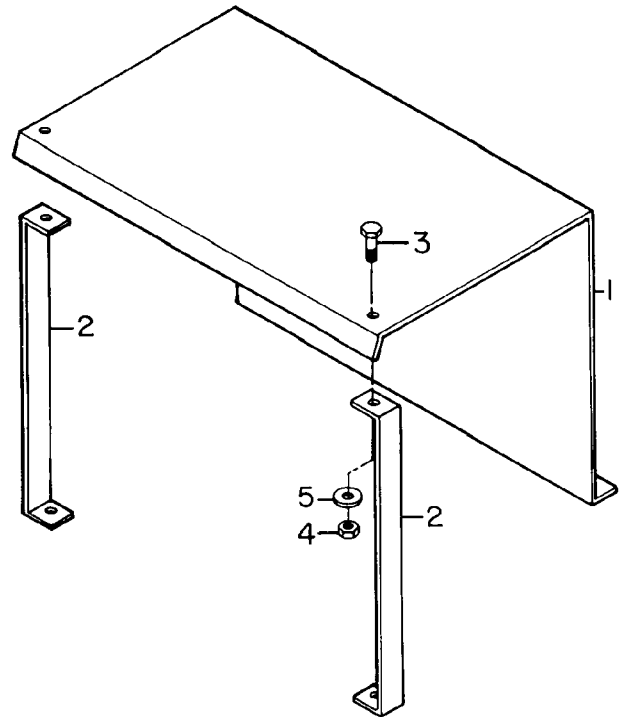

**AIR TANK BRACKET (CHAIN) - 15 GALLON
PART NUMBER 51704334**

1.	52701612	TANK BRACKET	2
2.	72062002	NUT 3/8-16	2
3.	72063051	WASHER 3/8 LOCK	2
4.	72063003	WASHER 3/8 WRT	2

NOTE: BRACKET MOUNTING HARDWARE IS NOT INCLUDED.
THE BRACKET (ITEM 1) IS DESIGNED FOR 1/2" DIA.
CAP SCREWS. YOUR INSTALLATION WILL DETERMINE
LENGTH.

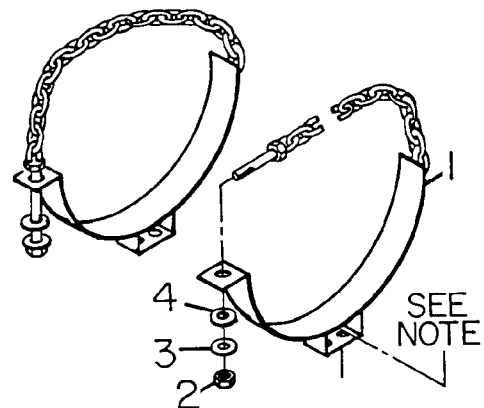

Section 5. ELECTRICAL OPTIONS

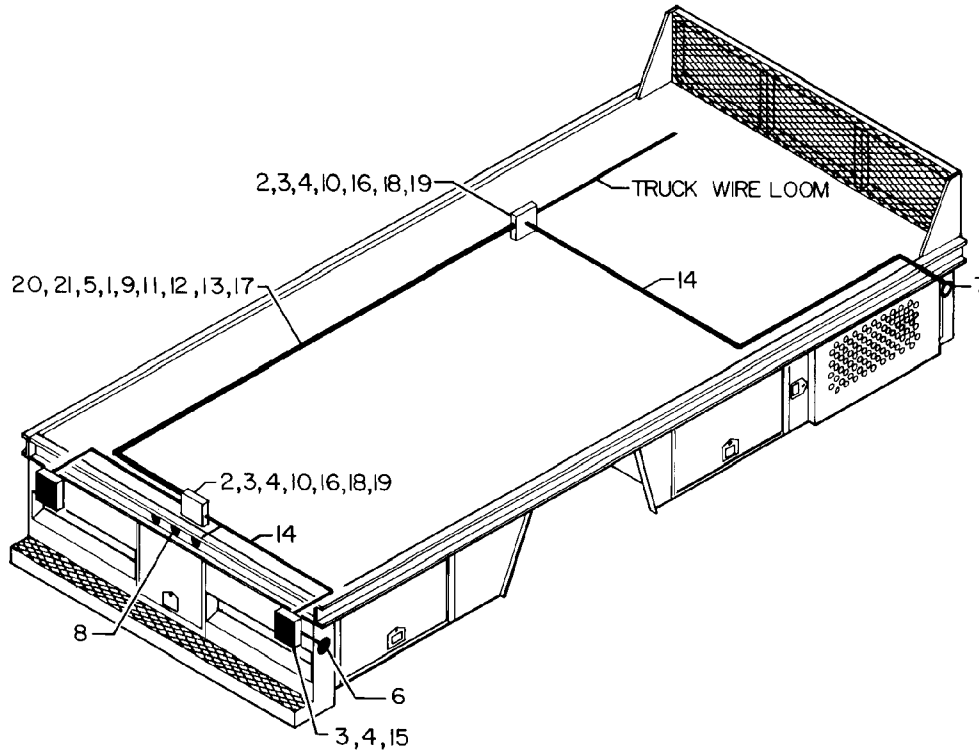

LIGHT AND WIRING KIT PART NUMBER 51708131

1.	89044231	WIRE - 14GA GRN X 24 FT	1
2.	72060004	CAP SCREW 1/4-20 X 1 HH GR5	4
3.	72062104	NUT 1/4-20 LOCK	8
4.	72063001	WASHER 1/4 WRT	8
5.	89044271	WIRE - 14GA BLU X 24 FT	1
6.	77040001	RED CLEARANCE LIGHT	2
7.	77040002	AMBER CLEARANCE LIGHT	2
8.	77040005	CLUSTER LIGHT	1
9.	77040048	BUTT TERMINAL	16
10.	77040049	BUTT CONNECTOR	3
11.	89044232	WIRE - 14GA RED X 24 FT	1
12.	89044233	WIRE - 14GA BRN X 24 FT	1
13.	89044234	WIRE - 14GA YEL X 24 FT	1
14.	89034271	FLEXIBLE CONDUIT 1/2" X 20 FT	1
15.	77040208	LIGHT	2
16.	77044293	CONDUIT BOX	2
17.	83044000	CONDUIT 1/2" X 10 FT	1
18.	77044075	CONNECTOR - 1/2" LIQ TITE	4
19.	77044076	CONNECTOR - 1/2" X 90 DEG	4
20.	89044274	WIRE - 14GA BLK X 24 FT	1
21.	89044235	WIRE - 14GA WHT X 24 FT	1

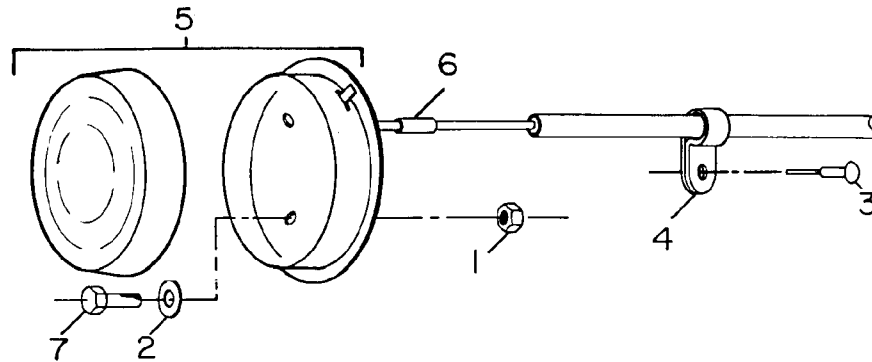

**COMPARTMENT LIGHT KIT
PART NUMBER 51706356**

1.	72062106	NUT #10-24 LOCK	3
2.	72063123	WASHER #10-24 WRT	6
3.	72066340	POP RIVET 1/8 X 3/8	10
4.	72066534	CLAMP - VINYL	10
5.	77040017	LIGHT	1
6.	77040049	BUTT CONNECTOR	1
7.	72601284	MACH SCREW #10-24 X 5/8	3
8.	89044234	WIRE - 14GA YELLOW X 180"	1
9.	89044351	LOOM - .33 ID X 180"	1

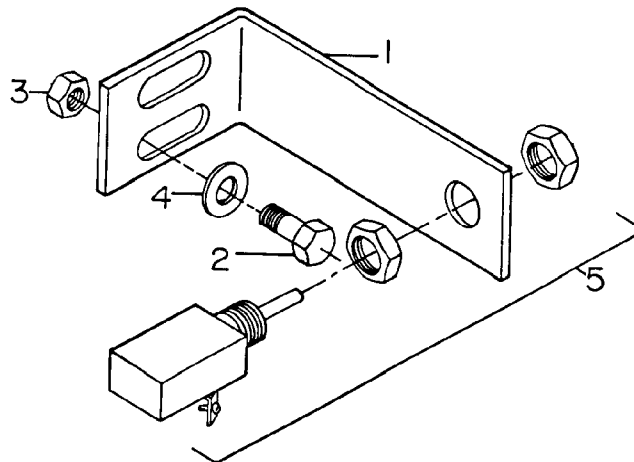

**DOOR ACTIVATED SWITCH KIT
PART NUMBER 51707400**

1.	60111003	BRACKET	1
2.	72060004	CAP SCREW 1/4-20 X 1 HH GR5	2
3.	72062104	NUT 1/4-20 LOCK	2
4.	72063001	WASHER 1/4 WRT	4
5.	77041015	SWITCH	1
6.	77040048	BUTT CONNECTOR	2
7.	77040051	TERMINAL	2

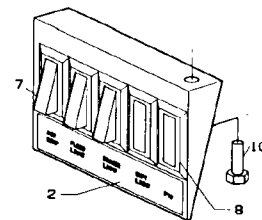
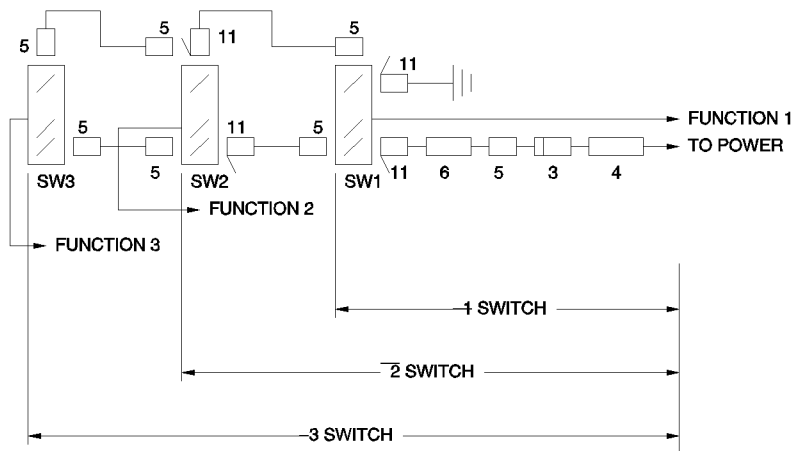

LIGHT SWITCH KITS

- A. 1-SWITCH 51706353**
- B. 2-SWITCH 51706354**
- C. 3-SWITCH 51706355**

		A	B	C
1.	70034376 SWITCH BRACKET	1	1	1
2.	70393153 DECAL (SEE NOTE)	1	1	1
3.	77040047 TERMINAL-MSLPON 1/4 TAB	1	1	1
4.	77040048 BUTTCONNECTOR	1	1	1
5.	77040186 TERMINAL-FSLPON 1/4 TAB	3	5	7
6.	77041056 FUSE 20AMP IN-LINE	1	1	1
7.	77041386 SWITCH-SGL POLE LIT	1	2	3
8.	77041387 SWITCH PLATE-BLANK	4	3	2
9.	89044232 WIRE 14GA RED	SPEC LENGTH		
10.	72061144 SHT MTL SCR #10X1/2	2	2	2
11.	77040137 TERMINAL #12-10 1/4 TAB		2	4
12.	89044274 WIRE 14GA BLK(GRD-NOT SHOWN)	SPEC LENGTH		
13.	89044271 WIRE 14GA BLU(NOT SHOWN)	SPEC LENGTH		
14.	77040053 TERMINAL RING (NOT SHOWN)	1	1	1

NOTE: DECAL (ITEM 2) PROVIDES 5 FUNCTIONS, CUT AS REQD.

**FLOODLIGHT KIT - 12 VOLT - 5" DIAMETER
PART NUMBER 51706357**

- | | | | |
|----|----------|---------------------------|----|
| 1. | 72066340 | POP RIVET 1/8 X 3/8 | 10 |
| 2. | 72066534 | CLAMP | 10 |
| 3. | 77040026 | FLOOD LIGHT - BLACK | 1 |
| 4. | 77040049 | BUTT CONNECTOR | 1 |
| 5. | 89044234 | WIRE - 14GA YELLOW X 180" | 1 |
| 6. | 89044351 | LOOM - .33 ID X 180" | 1 |

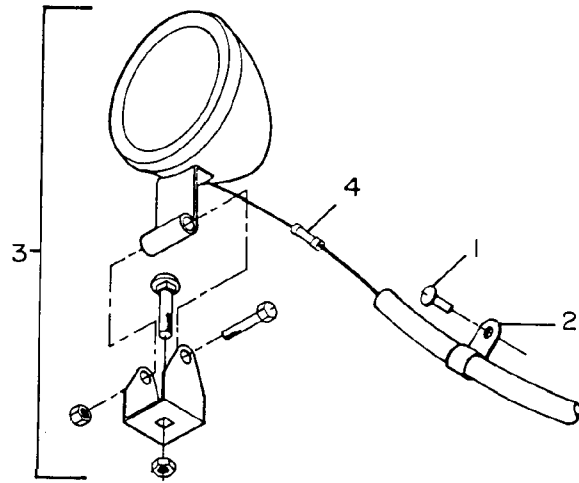

**FLOODLIGHT STAND
PART NUMBER 51707346**

- | | | | |
|----|----------|------------------------------|---|
| 1. | 52707345 | STAND | 1 |
| 2. | 70392310 | PLUG | 2 |
| 3. | 72060070 | CAP SCREW 7/16-14 X 3 HH GR5 | 2 |
| 4. | 72062003 | NUT 7/16-14 HEX | 2 |
| 5. | 72063052 | WASHER 7/16 LOCK | 2 |
| 6. | 72062004 | WASHER 7/16 WRT | 2 |

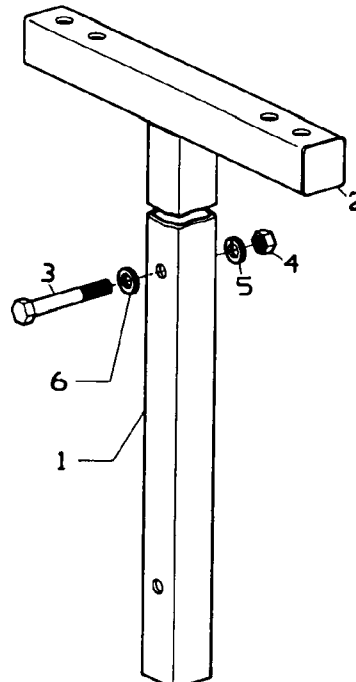

Section 6. MISCELLANEOUS OPTIONS

DRAWER SET PART NUMBER 51706978

- | | | | |
|----|----------|---------|---|
| 1. | 52710274 | DRAWER | 1 |
| 2. | 60114979 | DIVIDER | 1 |
| 3. | 60114952 | CABINET | 1 |

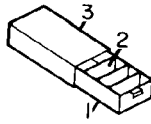

4-DRAWER SET WITH RISER PART NUMBER 51704193

- | | | | |
|----|----------|--------------------------------|----|
| 1. | 52710274 | DRAWER | 4 |
| 2. | 52710227 | CABINET - 4 DRAWER | 1 |
| 3. | 60114979 | DIVIDER | 12 |
| 4. | 72060023 | CAP SCREW 5/16-18 X 3/4 HH GR5 | 4 |
| 5. | 72062109 | NUT 5/16-18 LOCK | 4 |
| 6. | 72063002 | WASHER 5/16 WRT | 8 |

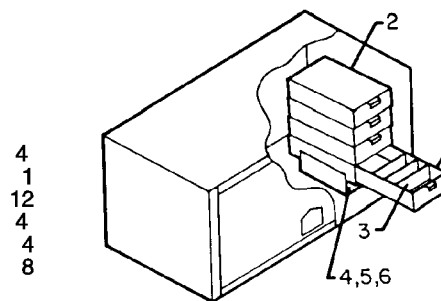

ADJUSTABLE SHELF - FULL LENGTH 17 X 37 - 41 PART NUMBER 51707188

- | | | | |
|----|----------|------------------------------|---|
| 1. | 60110246 | END - LH | 1 |
| 2. | 60110247 | END - RH | 1 |
| 3. | 60114600 | SHELF | 1 |
| 4. | 72060025 | CAP SCREW 5/16-18 X 1 HH GR5 | 4 |
| 5. | 72062109 | NUT 5/16-18 LOCK | 4 |
| 6. | 72063001 | WASHER 1/4 WRT | 4 |

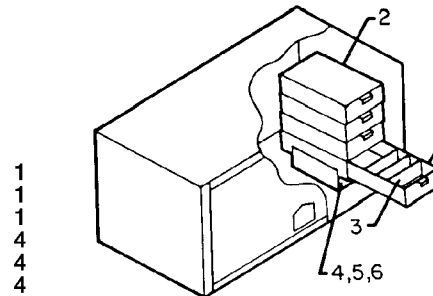

ADJUSTABLE SHELF - FULL LENGTH 21 X 51 - 55 PART NUMBER 51707376

- | | | | |
|----|----------|------------------------------|---|
| 1. | 60110251 | END - LH | 1 |
| 2. | 60110252 | END - RH | 1 |
| 3. | 60110979 | SHELF | 1 |
| 4. | 72060025 | CAP SCREW 5/16-18 X 1 HH GR5 | 4 |
| 5. | 72062109 | NUT 5/16-18 LOCK | 4 |
| 6. | 72063001 | WASHER 1/4 WRT | 4 |

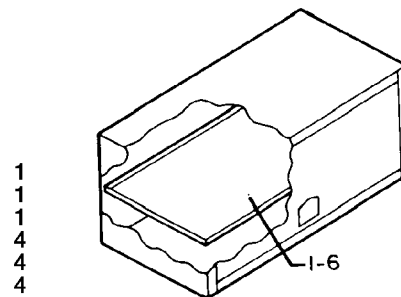

**SHELF DIVIDER ASSEMBLY
PART NUMBER 51707378**

1.	52707377	DIVIDER W/HANGER BRACKETS	1
2.	72060046	CAP SCREW 3/8-16 X 1 HH GR5	5
3.	72062103	NUT 3/8-16 LOCK	5
4.	72063003	WASHER 3/8 WRT	10

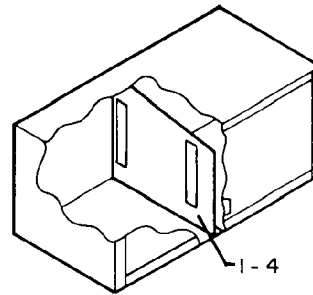

**SHELF KIT WITH DIVIDER ASSEMBLY 21 X 26
PART NUMBER 51707379**

1.	51706927	SHELF (INCL: 1A - 1F)	1
1A.	60110251	END - LH	1 REF
1B.	60110252	END - RH	1 REF
1C.	60114620	SHELF	1 REF
1D.	72060025	CAP SCREW 5/16-18 X 1 HH GR5	4 REF
1E.	72062109	NUT 5/16 LOCK	4 REF
1F.	72063001	WASHER 1/4 WRT	4 REF
2.	51707378	SHELF DIVIDER ASSEMBLY	1

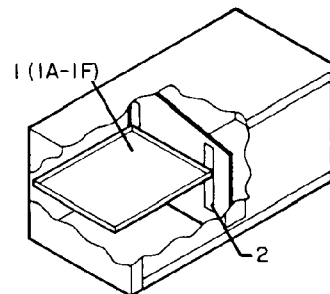

**SHELF KIT WITH DIVIDER ASSEMBLY 21 X 18
PART NUMBER 51707380**

1.	51706926	SHELF (INCL: 1A - 1F)	1
1A.	60110251	END - LH	1 REF
1B.	60110252	END - RH	1 REF
1C.	60114619	SHELF	1 REF
1D.	72060025	CAP SCREW 5/16-18 X 1 HH GR5	4 REF
1E.	72062109	NUT 5/16 LOCK	4 REF
1F.	72063001	WASHER 1/4 WRT	4 REF
2.	51707378	SHELF DIVIDER ASSEMBLY	1

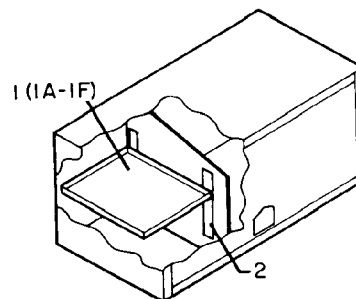

SOCKET TRAY ASSEMBLY
PART NUMBER 51708922
 NOTE: REQUIRES RIVETING.
 RIVETS, 72661226 INCLUDED.

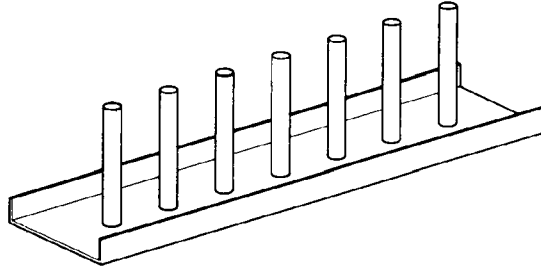

VALVE STEM TRAY
PART NUMBER 52704479
 NOTE: REQUIRES RIVETING.
 RIVETS, 72661226 INCLUDED.

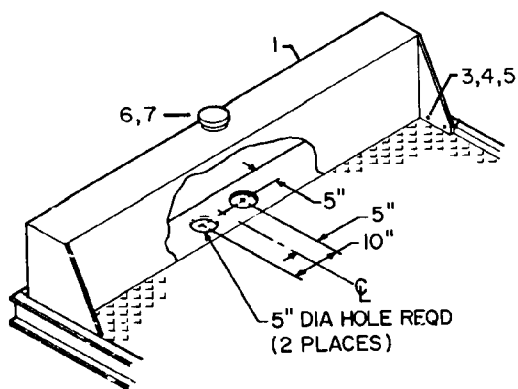
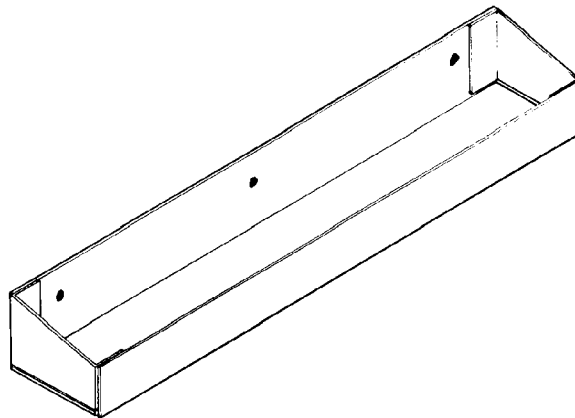

SKID RACK / RESERVOIR ASSEMBLY
PART NUMBER 51707238

1.	52707413	SKID RACK RESERVOIR	1
2.	60111861	SHIM	2
3.	72060093	CAP SCREW 1/2-13 X 1 1/2 HH GR 5	4
4.	72062080	NUT 1/2-13 LOCK	4
5.	72063005	WASHER 1/2 WRT	8
6.	73014671	FILL CAP	1
7.	73141276	FILL NECK SCREEN	1
8.	99900209	INSTALLATION DRAWING	1

Section 7. SAFETY EQUIPMENT

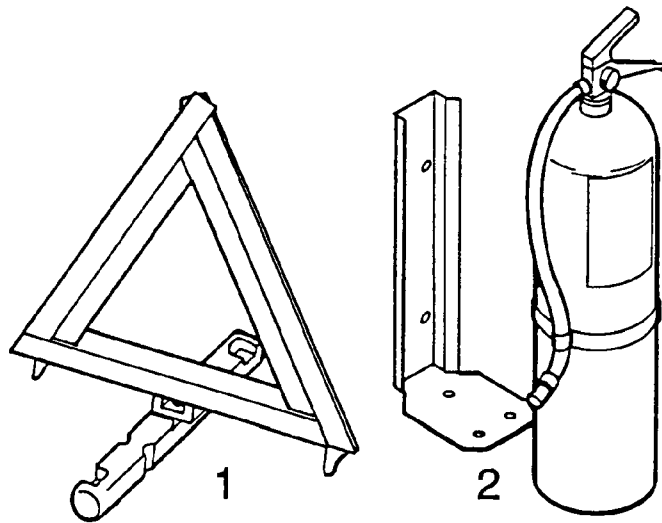

I.C.C. SAFETY KIT PART NUMBER 92091010

- 1. 70073146 TRIANGULAR REFLECTOR KIT 1
(Includes 3 reflectors and case)
- 2. 70073147 FIRE EXTINGUISHER 1
(with bracket)

INDIVIDUAL FIRE EXTINGUISHERS

- 70073622 FIRE EXTINGUISHER - 10 LB W/BRKT
- 70073091 FIRE EXTINGUISHER - 20 LB W/BRKT

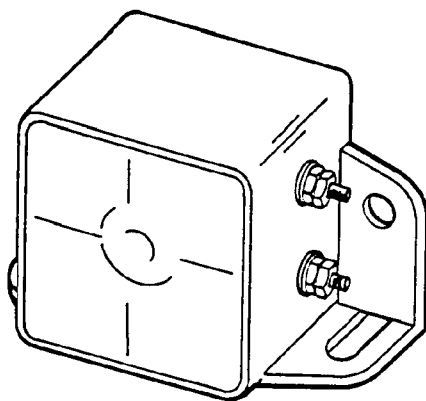

INSTALLATION WITH BACK-UP LIGHT NEGATIVE GROUND

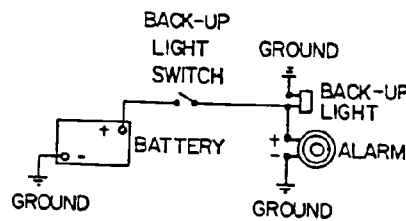

INSTALLATION WITH SWITCH NEGATIVE GROUND

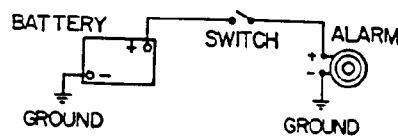

ELECTRIC BACKUP ALARM PART NUMBER 77040020

NOTE: USE 5/16" MOUNTING SCREWS AND LOCK NUTS (NOT INCLUDED).
SEE INSTALLATION INSTRUCTIONS WHICH ACCOMPANY ALARM.

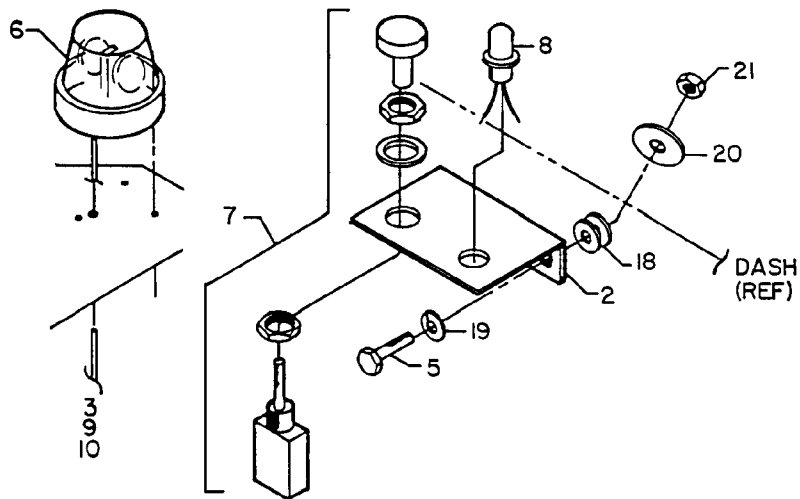

**ROTATING BEACON LIGHT - AMBER (INCLUDES MOUNTING KIT)
77040013**

NOTE: SEE INSTALLATION INSTRUCTIONS WHICH ACCOMPANY
THE BEACON LIGHT.
USE AN EXISTING SWITCH BRACKET OR THE INDIVIDUAL
PARTS LISTED BELOW FOR SWITCH MOUNTING.

2.	60103464	DASH BRACKET	1
3.	70034083	NYLON CLAMP - 7/16"	3
4.	70391251	DECAL-BEACON LIGHT	1
5.	72060004	CAP SCR 1/4-20X1 HH GR5	2
7.	77041014	PUSH/PULL SWITCH W/20AMP FUSE	1
8.	77042001	RED INDICATOR LIGHT	1
9.	89044001	WIRE 14 GA (SPECIFY LENGTH)	
10.	89044073	CONDUIT 1/2" FLEX (SPECIFY LENGTH)	
18.	72063001	WASHER 1/4 WRT	4
19.	72063049	WASHER 1/4 LOCK	2
20.	72063078	WASHER 5/16X1 5/8 O.D.	2
21.	72062000	NUT 1/4-20 HEX	2

LIMITED WARRANTY

WARRANTY COVERAGE - Products manufactured by Iowa Mold Tooling Co., Inc. (IMT) are warranted to be free from defects in material and workmanship, under proper use, application and maintenance in accordance with IMT's written recommendations, instructions and specifications as follows:

1. Ninety (90) days; labor on IMT workmanship from the date of shipment to the end user.
2. One (1) year; original IMT parts from the date of shipment to the end user.

IMT's obligation under this warranty is limited to, and the sole remedy for any such defect shall be the repair or replacement (at IMT's option) of unaltered parts returned to IMT, freight prepaid, and proven to have such defect, provided such defect occurs within the above stated warranty period and is reported within fourteen (14) days of its occurrence.

IMPLIED WARRANTY EXCLUDED - This is the only authorized IMT warranty and is in lieu of all other express or implied warranties or representations, including any implied warranties of merchantability or fitness for any particular purpose or of any other obligations on the part of IMT.

ITEMS EXCLUDED - The manufacturer gives no warranty on any components purchased by the manufacturer, and such components as are covered only by the warranties of their respective manufacturers.

WARRANTY CLAIMS - Warranty claims must be submitted and shall be processed in accordance with IMT's established warranty claim procedure.

WARRANTY SERVICE - Warranty service will be performed by any IMT distributor authorized to sell new IMT products of the type involved or by any IMT Service Center authorized to service the type of product involved or by IMT in the event of direct sales made by IMT. At the time of requesting warranty service, the purchaser must present evidence of the date of delivery of the product. The purchaser shall pay any premium for overtime labor requested by the purchaser, any charge for making service calls and for transporting the equipment to the place where warranty work is performed.

WARRANTY VOIDED - All obligations of IMT under this warranty shall be terminated: (1) if service other than normal maintenance or normal replacement of service items is performed by someone other than an authorized IMT dealer, (2) if product is modified or altered in ways not approved by IMT.

PURCHASER'S RESPONSIBILITY - This warranty covers only defective material and workmanship. It does not cover depreciation or damage caused by normal wear, accident, improper protection in storage, or improper use. The purchaser has the obligation of performing the care and maintenance duties discussed in IMT's written recommendations, instructions and specifications. Any damage which results because of purchaser's failure to perform such duties shall not be covered by this warranty. The cost of normal maintenance and normal replacement of service items such as filters, belts, etc. shall be paid by the purchaser.

CONSEQUENTIAL DAMAGES - The only remedies the purchaser has in connection with the breach or performance of any warranty on IMT products are those set forth above. In no event will the dealer, IMT or any company affiliated with IMT, be liable for business interruptions, loss of sales and/or profits, rental or substitute equipment, costs of delay or for any other special, indirect, incidental or consequential losses, costs or damages.

REPRESENTATIONS EXCLUDED - IMT products are subject to no expressed, implied or statutory warranty other than herein set forth, and no agent, representative or distributor of the manufacturer has any authority to alter the terms of this warranty in any way whatsoever or to make any representations or promises, express or implied, as to the quality or performance of IMT products other than those set forth above.

CHANGE IN DESIGN - IMT reserves the right to make changes in design or improvements upon its products without imposing any obligation upon itself to install the same upon its products theretofore manufactured.

Effective January, 1985

This parts manual is provided to the user to assist in servicing the equipment. It is the property of Iowa Mold Tooling Co., Inc and, as such, may not be reproduced either whole or in part, whether by chemical, electrostatic, mechanical or photographic means without the expressed written permission of an officer of Iowa Mold Tooling Co., Inc. One manual is provided with each piece of new equipment and additional manuals may be obtained at a nominal price.



IOWA MOLD TOOLING CO., INC.

BOX 189, GARNER, IA 50438-0189

TEL: 515-923-3711

PRODUCT SUPPORT FAX: 515-923-2424