

# **Model HD-950 Underhood Air Compressor**

**IOWA MOLD TOOLING CO., INC.**  
500 HWY 18 WEST, GARNER, IOWA 50438  
515 - 923 - 3711

MANUAL PART NO. 99900950  
11/90

**REVISED**  
03-10-92  
05-01-92

# Table of Contents

PARAGRAPH	TITLE	PAGE
<b>SECTION 1. SPECIFICATIONS</b>		
1-1.	GENERAL	1
1-2.	SPECIFICATIONS	1
<b>SECTION 2. INSTALLATION</b>		
2-1.	GENERAL	1
2-2.	AIR COMPRESSOR	1
2-3.	UNDERDASH SWITCH	1
2-4.	UNDERHOOD SWITCH	2
2-5.	ELECTRIC SPEED CONTROL	2
<b>SECTION 3. OPERATION</b>		
3-1.	GENERAL	3
3-2.	OPERATION	3
<b>SECTION 4. MAINTENANCE</b>		
4-1.	GENERAL	4
<b>SECTION 5. REPAIR</b>		
5-1.	GENERAL	8
5-2.	PISTON RING REPLACEMENT	8
5-3.	OIL PUMP REPLACEMENT	9
5-4.	CRANKSHAFT AND BEARING REPLACEMENT	9
5-5.	CLUTCH REPLACEMENT	10
5-6.	TROUBLESHOOTING	11
	REPAIR KITS	12

# Section 1. SPECIFICATIONS

## 1-1. GENERAL

The IMT HD-950 air compressor is an underhood, engine mounted, single stage, air cooled, 4-cylinder, pressure lubricated unit, with a delivery rate of 30 CFM at 1400 RPM.

The compressor is belt driven from the engine crankshaft, through a magnetic clutch. It is engaged and disengaged by use of an air pressure sensing, electric switch. The pressure switch is preset on factory installed units at approximately 120 PSI to engage, and 150 PSI to disengage.

## 1-2. SPECIFICATIONS

Bore	2 5/8"
Stroke	2-1/2"
Cylinder Configuration	V4
Displacement	43.8 CFM*
Delivery	30 CFM*
Lubrication	Oil Pump
Cooling	Air/Water
Height	13-11/16"
Width	17-1/4"
Length	13 7/8"
Material	Aluminum Alloy
* Based on 1400RPM	

# Section 2. INSTALLATION

## 2-1. GENERAL

This section pertains to the installation of the IMT Model HD-950 compressor and related components. Because installations will vary somewhat, dependant on the chassis, it will describe the installation in general terms only.

## 2-2. AIR COMPRESSOR

Each installation will differ dependant on the chassis make, model, year of manufacture, and optional equipment. Refer to the mounting kit for specific information relating to your application.

## 2-3. UNDERDASH SWITCH

The installation kit will include the correct bracket for the installation of the compressor power switch and the engine speed control. The bracket may house switches for other functions, depending on the total system.

1. Drill mounting holes in the underside of the dash. It may be possible to utilize existing holes.
2. Install the switch, or switches, needed for your installation.
3. Route the needed wiring harness to the rear of the bracket, and connect to the proper switches.
4. Securely fasten the assembled switch bracket to the dash with bolts, nuts, and washers provided.

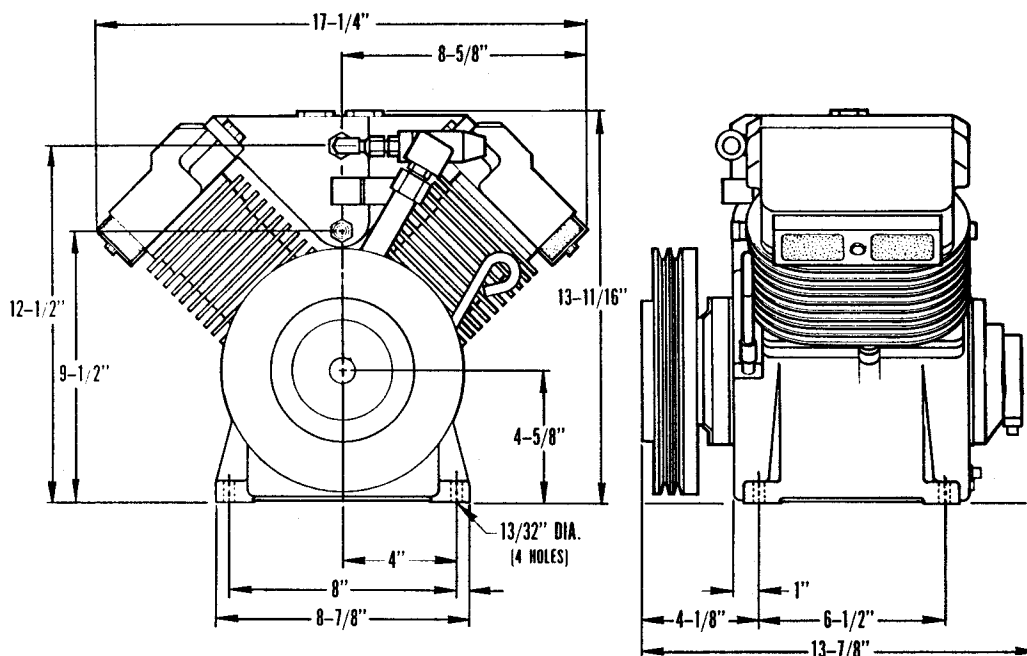

## NOTE

If the dashboard is plastic, the ground wire must be connected to chassis ground. The plastic dashboard is not conductive and will not provide a ground.

5. Connect the positive side of the compressor switch to the power switch. Connect the other side of the switch to the underhood safety switch and the indicator lamp.
6. Install the throttle cable mounting bracket to the underside of the dash, near the switch bracket. Install the cable and connect to the carburetor linkage. Make certain that there is enough free play to allow the engine to return to normal idle.

### 2-4.UNDERHOOD SWITCH

The purpose of the underhood switch is to prevent the compressor from running unless the vehicle's hood is raised. This will ensure a sufficient air flow to the compressor during operation.

1. Select a location for the mercury switch that will provide protection for the glass

envelope and keep the switch contacts open when the hood is closed. The mercury should not be in contact with the contacts to accomplish this.

2. Drill a 1/16 inch hole in the desired location and install the switch bracket. Install the switch in the bracket. Connect one lead to the underdash switch, the other to the compressor pressure switch. When wired properly, the switch in the cab must be on and the hood must be raised in order for the compressor to operate.

## CAUTION

Warranty on the compressor will be void if the underhood safety switch is not used. Failure to use this switch will allow the compressor to operate with the hood closed and will cause overheating.

### 2-5.ELECTRIC SPEED CONTROL

An optional electric engine speed control may be used in lieu of the manual speed control. On units equipped with an electric speed control, the engine speed will automatically increase when the clutch is engaged, and decrease when the clutch is disengaged.

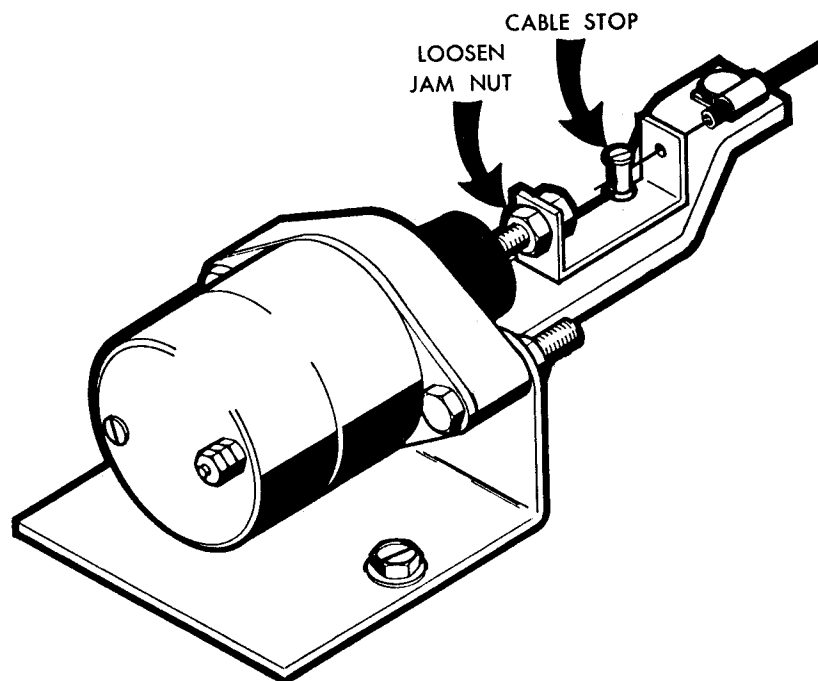

# Section 3. OPERATION

## 3-1.GENERAL

Each compressor is bench tested under load at the factory to ensure proper break-in and operation. While it is not necessary to follow any break-in procedure, the following checks should be made before putting the unit into service, as well as, periodically during use.

### 1. Before start-up:

A. Check the oil level in the compressor crankcase with the dipstick on the unit. If oil is needed, use only IMT's synthetic compressor oil.

B. Check the air intake filter pads on each head to make certain that they are clean and unobstructed. Dirty filters are a possible cause of reduced air output.

### 2. With the compressor engaged:

On units having the automatic speed control option, check the engine RPM for proper setting (1400 RPM max.) under compressor load. If adjustment is required, loosen the jam nut as shown, and make the necessary adjustment. Retighten the jam nut.

## 3-2.OPERATION

To use the compressor, raise the hood to provide adequate ventilation, start the vehicle engine, and engage the compressor by operating the compressor switch in the cab. On systems without automatic engine speed control, adjust the engine RPM with the manual throttle cable to maintain the proper RPM setting while the compressor is pumping.

The system will now function automatically. It will engage the compressor clutch when the air pressure is below 120 psi, and disengage when the air pressure reaches 150 psi.

### NOTE

On units with manual engine speed control, the engine RPM will increase when the compressor clutch disengages.

### CAUTION

This unit is equipped with an underhood safety switch which requires that the hood be raised while the compressor is in operation. This is installed to ensure that the unit has adequate ventilation, and that the unit is not inadvertently left on when not in use and the vehicle is in motion. Bypassing this safety device, or operating this unit in excess of 1400 RPM, will void the warranty, and will shorten the normal service life of the compressor.

# Section 4. Maintenance

## 4-1. GENERAL

The following table is a list of routine maintenance items, including service intervals. It also includes a parts list and assembly drawing of the compressor.

### ROUTINE MAINTENANCE CHECK LIST

Maintenance Operation	Service Intervals		
	Weekly	500/3	1000/6
Air intake - inspect and clean			
Crankcase oil level - check, add if needed			
Crankcase oil quality- check, change if necessary	SEE NOTE 1.		
Compressor valves - inspect and clean			
Cooling vanes (fins) - clean			
Safety valves - check operation			
Safety valves - clean			
Belt tension - check			
Electric clutch - check operation			
Air receiver - drain condensation			
Receiver safety valves - check operation			
Tighten and check all valves			
Check all electrical connections			
Check fittings and air lines for leaks			
Inspect check valves for proper operation			
Inspect check valves for carbon buildup			

Service intervals are listed as hours/months, whichever occurs first.

Use only IMT's synthetic compressor oil. The use of any other oil causes excessive carbon buildup, and will void the warranty on the compressor.

NOTE 1. Under normal operating conditions, oil changes are required every 12 months. It is advisable to check the oil quality at least every 6 months, especially when operating in a dirty environment. Change the oil more frequently as your particular operating conditions dictate.

**HD950 UNDERHOOD AIR COMPRESSOR  
PART NO. 51706305**

ITEM	PART NO.	DESCRIPTION	QTY	ITEM	PART	DESCRIPTION	QTY
1.	60025012	CRANKCASE (PART OF 94)	1REF	56.	77044419	COIL	1
2.	60025194	CYLINDER BLOCK	2	57.	76039119	SEAL (PART OF 91)	1REF
3.	60025195	CYLINDER HEAD	2	58.	60025007	FRT BRG HSG (PART OF 91)	1REF
4.	60025193	PULSATION TANK	1	59.	70055011	FRT BRG CUP (PART OF 91)	1REF
5.	70731375	VALVE PLATE	2	60.	70055012	FRT BRG CONE (PART OF 93)	1REF
6.	73073030	DIPSTICK	1	61.	60108748	CRANKSHAFT (PART OF 93)	1REF
7.	70014613	DIPSTICK TUBE	1	62.	72066267	WOODRUFF KEY #6	1
8.	60101270	OIL SCREEN TUBE (PART OF 94)	1REF	63.	70055009	REAR BRG CONE (PART OF 93)	1REF
9.	70014610	OIL SCREEN (PART OF 94)	1REF	64.	60101269	OIL PUMP COLLAR (PART OF 93)	1REF
10.	72066008	OIL SCREEN CLAMP(PART OF 94)	1REF	65.	72066307	DRIVE PIN (PART OF 93)	1REF
11.	60101507	OIL FILL PIPE	1	66.	70055010	REAR BRG CUP (PART OF 92)	1REF
12.	51705310	BREATHER CAP (INCL:95,96)	1	67.	60025005	REAR BRG HSG (PART OF 92)	1REF
13.	72063050	WASHER 5/16 LOCK (PART OF 94)	5REF	68.	70014583	COIL SPRING	1
14.	72053403	PLUG 3/8NPT (PART OF 94)	1REF	69.	60101505	SLEEVE	1
15.	72053413	PLUG 3/8NPT (PART OF 94)	1REF	70.	70051006	OIL PUMP	1
16.	70039300	IDENTIFICATION PLATE	1	71.	60025006	PUMP COVER	1
17.	72063001	WASHER 1/4 FLAT	12	73.	72053411	PLUG 1/8NPT	2
18.	60107246	AIR INTAKE RETAINER	2	74.	72060731	CAP SCR 5/16X3/4(PART OF 94)	5REF
19.	70393505	FILTER-AIR INTAKE	2	75.	72060731	CAP SCR 5/16X3/4 SH	4
20.	72060032	CAP SCR 5/16X2-3/4	12	76.	51029283	CONNECTING ROD	4
21.	72060063	CAP SCR 7/16X1-1/4	4	77.	51029285	PISTON ASSEMBLY	4
22.	72062036	NUT 5/16	12	78.	70014627	WRIST PIN (PART OF 77)	4REF
23.	76039111	GASKET	2	79.	72066018	RETAINING RING (PART OF 77)	8REF
25.	70024122	WASHER 5/16 FLAT COPPER	12	80.	70014600	OIL RING (PART OF 88)	4REF
26.	72063052	WASHER 7/16 LOCK	4	81.	70014599	COMPRESSION RING (PART OF 88)	4REF
27.	72063050	WASHER 5/16 LOCK	1	82.	76039092	GASKET-REAR BRG .006	2AR
28.	72063001	WASHER 1/4	2		76039094	GASKET-REAR BRG .010	2AR
29.	72060005	CAP SCR 1/4X1-1/4 GR5	2		76039144	GASKET-REAR BRG .020	2AR
30.	72053404	PLUG 1/2NPT	1		76039143	GASKET-REAR BRG .015	2AR
31.	7Q072212	O-RING	8	83.	76039093	PUMP COVER GASKET	1
32.	76391661	HEAD GASKET	2	84.	76039112	FRT BRG HSG GASKET	2
33.	76039114	CYL/VALVE PLATE GASKET	2	87.	72060025	CAP SCR 5/16X1(PART OF 94)	5REF
34.	76392119	CYL/SPACER GASKET	2	88.	51014947	RING SET	1
35.	70029293	CYLINDER BLOCK SPACER	2	91.	51705709	FRT BRG HSG (PART OF 94)	1REF
36.	60106933	CAP	2	92.	51705710	REAR BRG HSG (PART OF 94)	1REF
37.	72063129	WASHER 1/4 LOCK	2	93.	51705661	CRANKSHAFT ASM (PART OF 94)	1REF
38.	72066537	CABLE CLAMP	2	94.	51705744	CRANKSHAFT/CASE ASM	1
39.	72532716	BARBED NIPPLE 3/8NPT X 5/8	2	95.	60107276	MODIFIED CAP (PART OF 12)	1REF
40.	72066307	DRIVE PIN	1	96.	70048080	BREATHER (PART OF 12)	1REF
41.	76393107	O-RING	2	97.	51704358	INSERT ASM	2
42.	72066426	STEEL BALL (PART OF 97)	2REF	98.	70029468	SHIM (PART OF 97)	2REF
43.	70029377	INSERT (PART OF 97)	2REF	99.	70039124	DECAL-OIL FILL	1
44.	7Q073017	O-RING (PART OF 97)	2REF	100.	70029062	PISTON (PART OF 77)	4REF
53.	72053403	PIPE PLUG 3/8NPT SH	2	101.	72601060	STUD 5/16 X 2	12
54.	70732444	CLUTCH HARDWARE KIT (INCL: 55)	1	102.	76393085	O-RING (PART OF 97)	2REF
55.		PULLEY (PART OF 54)	1REF				
				51392148		GASKET SET (INCLUDES ITEMS 23, 31, 32, 33, 34, 57, 82, 83 AND 84)	REF

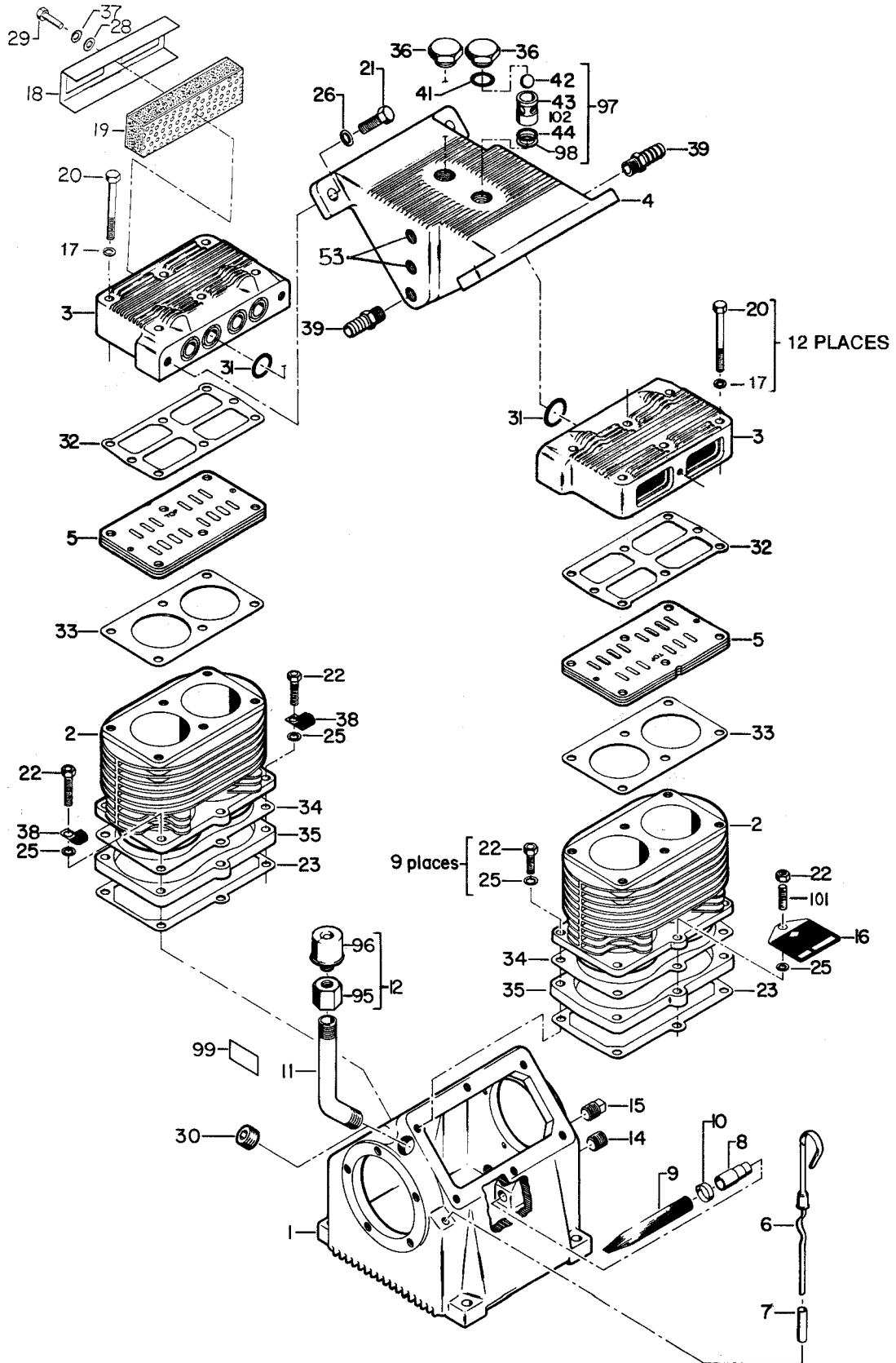



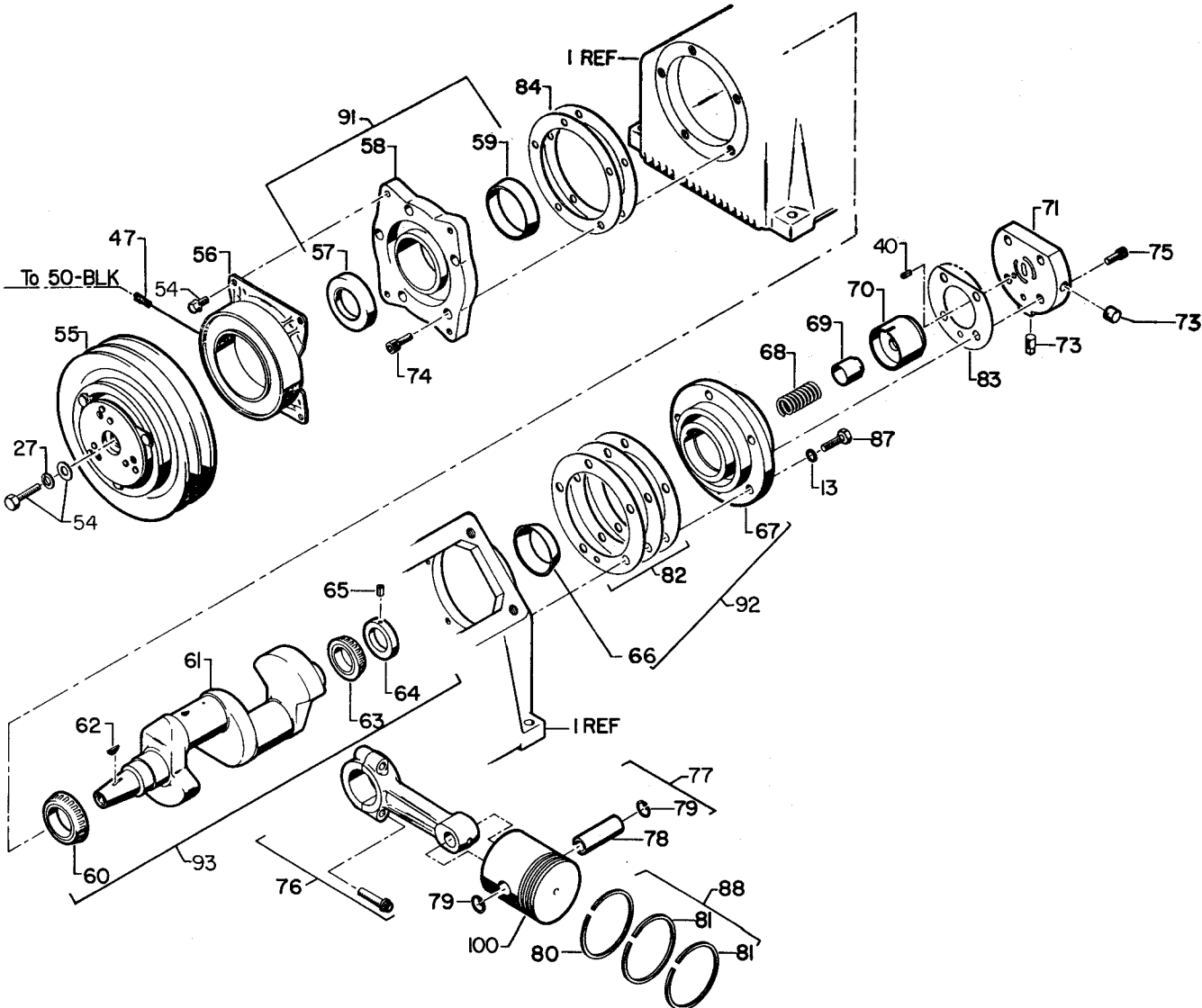

## Section 5. REPAIR

### 5-1. GENERAL

This section describes the disassembly and assembly procedures for the underhood air compressor. In all cases, remove the compressor from the vehicle before proceeding with disassembly. Refer to the parts drawing in section 4 of this manual for parts locations.

### 5-2. PISTON RING REPLACEMENT

1. Remove the pulsation tank.
2. Unscrew the head bolts and remove the heads.

#### NOTE

A rubber faced mallet will help when removing the head. Tap the sides of the head carefully until the head is loose. Lift off the heads.

3. Remove the cylinder bolts. Tap the sides of the cylinder several times to break it loose from the gasket. Rock the cylinder back and forth and lift until it is free. Lift it off the pistons.
4. Use a single edged razor blade, or sharp putty knife, to remove the old gasket material.

#### CAUTION

Do not allow the gasket material to fall into the crankcase. Do not nick the head, cylinder, or crankcase mating faces while removing the old gasket. Remove all of the old gasket material to provide a smooth, clean surface for the new gasket. Failure to follow this procedure may result in the need to reseal the unit later.

- 5.hone the cylinder to break the glaze and to remove the buildup at the top of the cylinders.
6. Measure the inside diameter of the cylinder for roundness and excessive wear. The bore should be 2.625" (0.0025" tolerance). If the bore is oversized, the cylinder must be replaced.

7. With a ring expander, remove the compression and oil rings.
8. With the ring expander, install the new ring kit. Make certain that the oil ring is on the bottom and the beveled inside edge of the compression ring is toward the top of the piston.
9. Position the cylinder base gasket on the crankcase. Use a few drops of oil to hold it in position. Install the cylinder block spacer and gasket on the crankcase.
10. Rotate the rings so that the gaps of the three rings are 120 degrees apart. Lightly lubricate the inside of the cylinder. Rotate the crankshaft so that a piston is at the top of the stroke. Compress the rings with a ring compressor, and slide the cylinder over the piston. Repeat for the other piston.

#### CAUTION

Do not lubricate the rings. Use a light lubricant, such as WD-40 only, on the cylinder walls. Oiling the rings will prevent them from seating and cause excessive oil consumption.

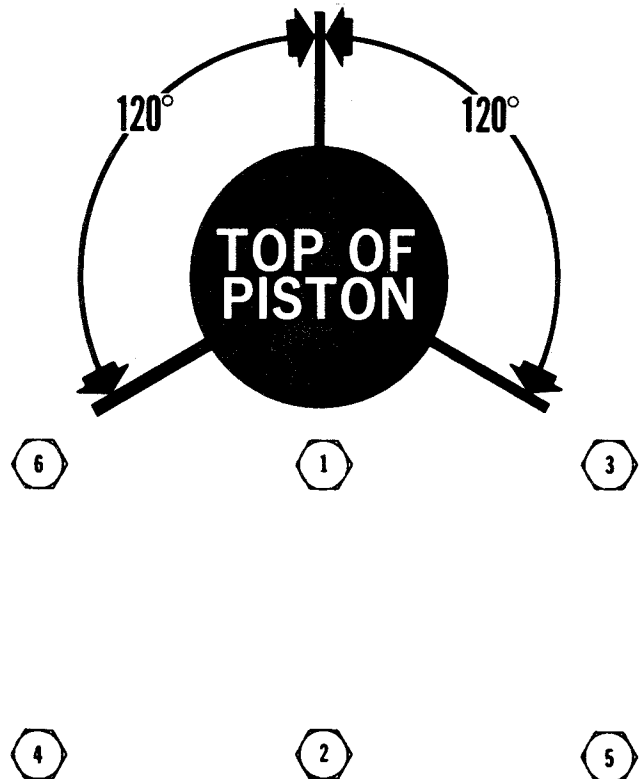

11. Slide the cylinder down until it mates with the crankcase. Start all cylinder mounting bolts, until they are snug. Torque the bolts to 180 inch pounds in the sequence shown. Do not torque to the full 180 inch pounds all at once. Torque in 25 - 50 pound increments.
12. Position the gaskets and valve plate on top of the cylinder. Position the head on the cylinder and turn all of the bolts finger tight. Torque in the same manner described in step 11.

#### NOTE

Install the valve plate with the marked surface facing up.

13. Install the pulsation tank, and torque to 180 inch pounds.
14. Install the compressor, connect the wiring and the air lines. Test the unit.

#### NOTE

If pressure fails to build and the compressor is excessively noisy, check the valve plate. It may have been installed upside down.

### 5-3.OIL PUMP REPLACEMENT

1. Remove the bolts and lift off the pump cover.
2. With a single edged razor blade, or sharp putty knife, remove the old gasket material. Take care not to damage the machined surfaces.
3. Lift the pump out of the cavity.
4. Position a new gasket on the rear bearing housing.
5. Insert the pump into the cavity. Position the pump slightly to one side, using a common screwdriver. Wedge the pump into position so that it partially compresses the spring.
6. Place the pump cover into position and start two bolts (bolts must be diagonally opposed). Strike the pump cover with a rubber faced mallet to jar the pump loose. When the tension spring can be felt against the pump cover, the pump is loose.
7. Insert the two remaining bolts and torque to 180 inch pounds. The bolts should be torqued in a diagonal pattern.

8. Install the air compressor in the vehicle. Connect the air lines and wiring.

### 5-4.CRANKSHAFT AND BEARING REPLACEMENT

If it is necessary to replace the crankshaft, related components must also be replaced. Replace both bearings, both races, the key, pump collar and pump drive pin.

#### NOTE

Depending on the condition of the crankshaft, bearing may be replaced without replacing the crankshaft. Replace the bearing races whenever the bearings are replaced.

1. Remove the pulsation tank, both heads, cylinders, and pistons. Refer to the instructions in section 5, paragraph 2.
2. Remove the bolts on the connecting rods, and lift them out. Reassemble the connecting rods to be certain that the matched parts remain together.
3. Remove the pump cover, oil pump, sleeve, spring, and rear bearing housing.
4. Remove the clutch and pulley assembly, and the front bearing housing.
5. Pull the crankshaft from he crankcase.
6. Remove all gasket material with a single edged razor blade, or sharp putty knife.

#### CAUTION

Do not gouge the machined surfaces when removing the gaskets. This may cause leaks.

7. Press the bearing races out of the bearing housing.
8. Press the tapered roller bearings off of the crankshaft if only the bearings are being replaced. If the crankshaft is to be replaced, discard the entire assembly.
9. Press the new bearings into position.

## NOTE

The crankshaft should have new bearings installed. If not, press the new bearings into position on the crankshaft.

10. Generously oil the front bearing race and install the front bearing housing with gasket. Torque the bolts to 180 inch pounds. Torque the bolts as shown in the pattern below.

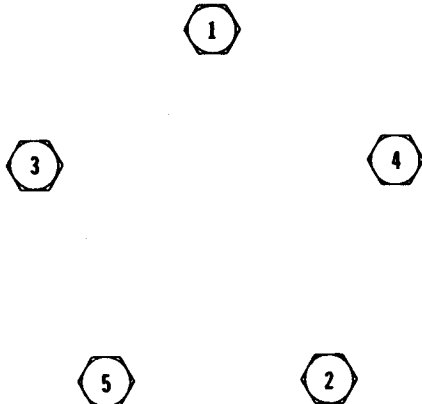

11. Slide the crankshaft into the crankcase. Generously lubricate the bearing race and install the rear bearing housing and gaskets.

## NOTE

Gasket kits are supplied with two (2) each of .006, .010, .015, and .020 gaskets. Use these rear bearing gaskets in any combination and quantity to limit all play front to rear, but still allow the crankshaft to turn freely.

12. Install the oil pump as indicated in section 5, paragraph 3.
13. Install the connecting rods. Thoroughly oil the crankshaft and rods before installing them. When installing the rods, make certain that the tabs are aligned on the same side of the rod as shown below.

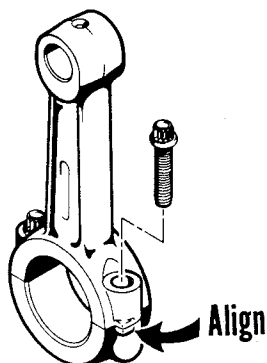

14. Install the pistons, rings, heads and pulsation tank. See section 5, paragraph

## 5-5. CLUTCH REPLACEMENT

### CAUTION

Clutch failure may be due to a leaking check valve. Make certain that the check valves are functioning properly before installing the new clutch. The check valves may be checked by pressurizing the tank and shutting off the compressor. There should be no air escaping from the unloader valve. If there is air escaping, the check valves are faulty.

The clutch assembly can be removed while the compressor is still on the vehicle. The following procedure should be used.

### WARNING

Attempting to start the engine while the clutch is being removed will cause serious injury.

1. Turn on the ignition switch, and move the compressor switch to the on position. This will engage the clutch, and make for easier removal.
2. Remove the bolt in the center of the pulley and insert a 5/8-11 bolt.
3. Tighten the 5/8-11 bolt until the pulley is forced off the crankshaft.
4. Loosen the drive belt and remove the pulley.

### NOTE

If the drive belt is loosened before the pulley is loose, it will be difficult to hold the pulley stationary while tightening the 5/8-11 bolt.

### CAUTION

Do not use a wheel puller on the outer rim of the pulley. This can result in damage to the clutch bearing.

5. Remove the four (4) bolts holding the coil assembly to the front of the compressor.

To reinstall the clutch:

1. Position the magnetic coil assembly over the front bearing housing and secure the assembly with the 1/4-20 bolts. Torque to 85 - 120 inch pounds.
2. Insert the woodruff key into the crankshaft slot.
3. Slide the pulley, spacer, and lock washer onto the end of crankshaft. Be certain that the pulley slot aligns with the woodruff key. Secure them with the 5/16-18 bolts.
4. Rotate the pulley assembly manually to check for interference between the pulley and the coil. If there is interference, disassemble the clutch and repeat the procedure.
5. Install and tighten the drive belts.
6. Connect the coil wire to the air pressure switch.

7. Move the compressor switch in the cab to the on position to activate the clutch. Tighten the center bolt in the pulley.
8. Test the unit for proper operation.

**NOTE**

If there is excessive clearance between the coil and the pulley, the clutch will not engage. Use three 1/4" flat washer as shims between the coil and the front bearing housing. Retest the unit. If the clutch operates properly, order four spacers to replace the washer shims.

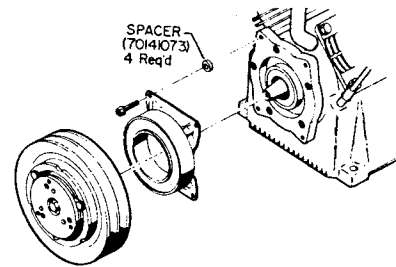

**5-6.TROUBLESHOOTING**

SYMPTOM	PROBABLE CAUSE
Low oil pressure	Low oil level
	Loose pipe plug on oil pump cover
	Worn or defective oil pump
	Crack or scratch on oilpump cover
No oil pressure	Defective oil pump
	Blocked oil passage
	Damaged oil pump drive pin
Compressor will not engage	Vehicle hood closed
	Blown fuse
	Defective clutch
	Defective pressure switch or underhood switch
Compressor engages but will not pressurize air tank	Air leak in plumbing
	Worn piston piston rings or valve plates
	Defective check valve/valves
Compressor does not recover pressure as fast as it should	Defective check valve/valves
	Dirty filters
	Loose fan belt
	Air leak in plumbing
	Worn valve plates or piston rings

# REPAIR KITS

## GASKET KIT - 51392148

7Q072212	O-RING	8
76039092	GASKET-REAR BRG HSG .006	2
76039093	GASKET-PUMP COVER	1
76039094	GASKET-REAR BRG HSG .010	2
76039111	GASKET-CYL BLOCK BOTTOM	2
76039112	GASKET-FRT BRG HSG	2
76039113	GASKET-VALVE COVER	2
76039114	GASKET-CYL BLOCK TOP	2
76039119	SEAL	1
76039143	GASKET-REAR BRG HSG .015	2
76039144	GASKET-REAR BRG HSG .020	2
76391661	GASKET-HEAD	2
76392119	GASKET-CYL BLOCK	2

## PISTON RING SET - 51014947

70014599	COMPRESSION RING	8
70014600	OIL RING	4

## CRANKSHAFT KIT - 51704269

51705742	CRANKSHAFT ASM (INCL: KEY & CRANK)	1
70055012	BEARING-FRT CONE	1
70055009	BEARING-REAR CONE	1
72066307	DRIVE PIN	1
60101269	OIL PUMP COLLAR	1
70055010	BEARING-REAR CUP	1
70055011	BEARING-FRT CUP	1

## CHECK VALVE KIT - 51704358

7Q073017	O-RING	1
70029377	CHECK VALVE INSERT	1
70029468	SHIM .53 ID X .94 OD X .005 THK	1
72066426	BALL .594 DIA	1
76393085	O-RING	1

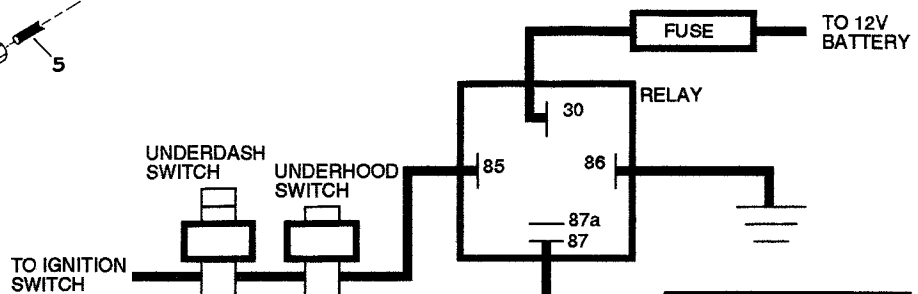
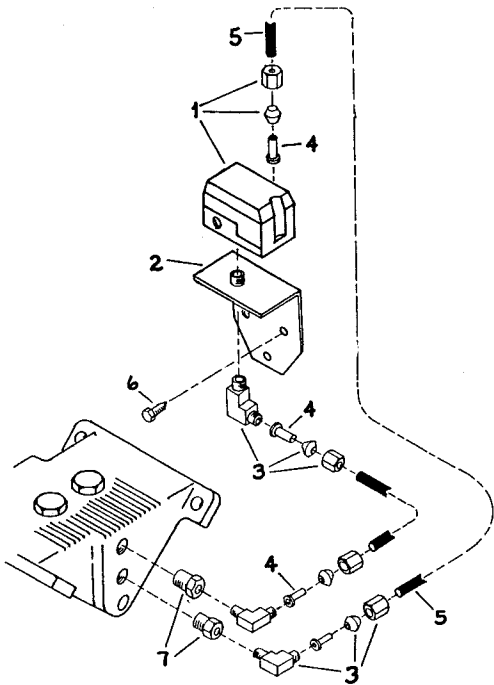

## PRESSURE SWITCH INSTALLATION 51710225

1.	77041369	PRESSURE SWITCH	1
2.	52710222	MOUNTING BRACKET	1
3.	72531042	ELBOW 1/8NPT 1/4 90°	3
4.	72532952	INSERT	4
5.	89034176	BRAKE LINE 1/4 AIR	10'
6.	72061004	SHT MTL SCR #14 X 3/4	3
7.	72531827	REDUCER BUSHING 3/8NPT 1/8NPT	2
8.	89044274	WIRE 14GA BLK	4'
9.	89044271	WIRE 14GA BLU	4'
10.	89044234	WIRE 14GA YEL	4'
11.	77040048	BUTT CONNECTOR 16-14GA	3
12.	77040051	TERMINAL 16-14GA SPADE	3
13.	89034048	SPIRAL WRAP	7"
14.	99900500	INSTALLATION DRAWING	1

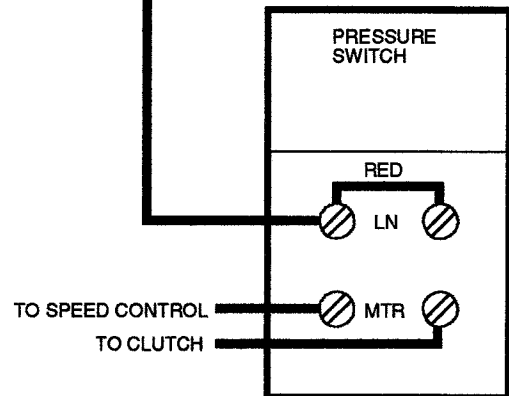

The information within this manual has been compiled and checked but errors do occur. To provide our customers with a method of communicating those errors we have provided the Manual Change Request form below. In addition to error reporting, you are encouraged to suggest changes or additions to the manual which would be of benefit to you. We cannot guarantee that these additions will be made but we do promise to consider them. When completing the form, please write or print clearly. Submit a copy of the completed form to the address listed below.

## MANUAL CHANGE REQUEST

DATE	PRODUCT MANUAL                      HD-950	MANUAL PART NO.                      99900950-11/90
SUBMITTED BY		
COMPANY		
ADDRESS		
CITY, STATE, ZIP		
TELEPHONE		

ERROR FOUND

LOCATION OF ERROR (page no.): \_\_\_\_\_

DESCRIPTION OF ERROR: \_\_\_\_\_

\_\_\_\_\_

\_\_\_\_\_

\_\_\_\_\_

\_\_\_\_\_

\_\_\_\_\_

\_\_\_\_\_

\_\_\_\_\_

REQUEST FOR ADDITION TO MANUAL

DESCRIPTION OF ADDITION: \_\_\_\_\_

\_\_\_\_\_

\_\_\_\_\_

\_\_\_\_\_

REASON FOR ADDITION: \_\_\_\_\_

\_\_\_\_\_

\_\_\_\_\_

MAIL TO: IOWA MOLD TOOLING Co., Inc.  
 Box 189,  
 Garner IA 50438  
 ATTN: Technical Publications

# MANUFACTURER'S LIMITED WARRANTY

**WARRANTY COVERAGE** - Products manufactured by Iowa Mold Tooling Co., Inc. (IMT) are warranted to be free from defects in material and workmanship, under proper use, application and maintenance in accordance with IMT's written recommendations, instructions and specifications as follows:

1. Ninety (90) days; labor on IMT workmanship from the date of delivery to the end user.
2. One (1) year; original IMT parts from the date of delivery to the end user.

IMT's obligation under this warranty is limited to, and the sole remedy for any such defect shall be the repair or replacement (at IMT's option) of unaltered parts returned to IMT, freight prepaid, provided such defect occurs within the above stated warranty period and is reported within fourteen (14) days of its occurrence.

**IMPLIED WARRANTY EXCLUDED** - This is the only authorized IMT warranty and is in lieu of all other express or implied warranties or representations, including any implied warranties of merchantability or fitness for any particular purpose or of any other obligations on the part of IMT.

**ITEMS EXCLUDED** - The manufacturer gives no warranty on any components or parts purchased by the manufacturer, and such components as are covered only by the warranties of their respective manufacturers.

**WARRANTY CLAIMS** - Warranty claims must be submitted and shall be processed in accordance with IMT's established warranty claim procedure.

**WARRANTY SERVICE** - Warranty service will be performed by any IMT distributor authorized to sell new IMT products of the type involved or by any IMT Service Center authorized to service the type of product involved or by IMT in the event of direct sales made by IMT. At the time of requesting warranty service, the purchaser must present evidence of the date of delivery of the product. The purchaser shall pay any premium for overtime labor requested by the purchaser, any charge for making service calls and for transporting the equipment to the place where warranty work is performed.

**WARRANTY VOIDED** - All obligations of IMT under this warranty shall be terminated: (1) if service other than normal maintenance or normal replacement of service items is performed by someone other than an authorized IMT dealer, (2) if product is modified or altered in ways not approved by IMT.

**PURCHASER'S RESPONSIBILITY** - This warranty covers only defective material and workmanship. It does not cover depreciation or damage caused by normal wear, accident, improper protection in storage, or improper use. The purchaser has the obligation of performing the care and maintenance duties discussed in IMT's written recommendations, instructions and specifications. Any damage which results because of purchaser's failure to perform such duties shall not be covered by this warranty. The cost of normal maintenance and normal replacement of service items such as filters, belts, etc. shall be paid by the purchaser.

**CONSEQUENTIAL DAMAGES** - The only remedies the purchaser has in connection with the breach or performance of any warranty on IMT products are those set forth above. In no event will the dealer, IMT or any company affiliated with IMT, be liable for business interruptions, loss of sales and/or profits, rental or substitute equipment, costs of delay or for any other special, indirect, incidental or consequential losses, costs or damages.

**REPRESENTATIONS EXCLUDED** - IMT products are subject to no expressed, implied or statutory warranty other than herein set forth, and no agent, representative or distributor of the manufacturer has any authority to alter the terms of this warranty in any way whatsoever or to make any representations or promises, express or implied, as to the quality or performance of IMT products other than those set forth above.

**CHANGE IN DESIGN** - IMT reserves the right to make changes in design or improvements upon its products without imposing any obligation upon itself to install the same upon its products theretofore manufactured.

Effective January, 1984

This parts manual is provided to the user to assist in servicing the equipment. It is the property of Iowa Mold Tooling Co., Inc and, as such, may not be reproduced either whole or in part, whether by chemical, electrostatic, mechanical or photographic means without the expressed written permission of an officer of Iowa Mold Tooling Co., Inc. One manual is provided with each piece of new equipment and additional manuals may be obtained at a nominal price.

**IOWA MOLD TOOLING Co., Inc.**  
500 Hwy 18 West - Garner - IA 50438  
515-923-3711