

DA435ELW: 99900917: 19980223



Model DA435ELW
Underhood Air Compressor



IOWA MOLD TOOLING CO., INC.

BOX 189, 500 HWY 18 WEST, GARNER, IA 50438

TEL: 515-923-3711

TECHNICAL SUPPORT FAX: 515-923-2424

MANUAL PART NUMBER 99900917

Model DA435ELW

Underhood Air Compressor

PACKING LIST

- 51713976 DA435ELW AIR COMPRESSOR
- 51713977 PRESSURE SWITCH KIT
- 51086090 COMPRESSOR OIL
- IMT ENVELOPE WITH FOLLOWING ENCLOSED:
 - 99900917 DA435ELW COMPRESSOR MANUAL
 - 71039134 DECAL-OIL LEVEL
 - 99900335 FORM-WARRANTY REGISTRATION
 - 77041251 RELAY
 - 71039165 DECAL

PRECAUTIONS

Read before operating your compressor!



71393886

! DANGER

EXPLODING TANK WILL CAUSE DEATH, SERIOUS INJURY OR PROPERTY DAMAGE

- Drain air tank after each use to prevent moisture build-up and corrosion which leads to tank failure.
- Assure that tank and compressor relief valves work properly, and are at correct pressure settings.
- **DO NOT** modify or repair air tank.
- **NEVER** drive vehicle with pressure in air tank.



Failure to follow operating and maintenance procedures as outlined in this manual could result in equipment damage, personal injury or death. Follow all maintenance procedures and intervals.



Do not use air from this compressor for breathing or food processing. Air from this compressor will cause severe injury or death if used for breathing or food processing.



Maintenance must be performed only by trained and qualified personnel, using correct tools, specified torques and approved replacement parts.

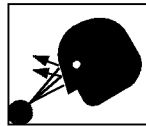

Hot oil under pressure can cause severe injury or death. Shut down, let cool and relieve pressure in compressor before servicing.



All electrical components and cable wiring must be installed and grounded in accordance with NFPA, national electrical codes and applicable state and local codes.



Do not overfill the compressor with oil. Use correct quantity of manufacturer's lubricant. Repair leaks and clean spills immediately.



Before removing guards or servicing the compressor, disconnect all power supplies. Display warning signs and lock out electrical circuits.



Compressors generate high temperatures. Do not touch or otherwise come in contact with hot surfaces. Doing so can cause severe personal injury.



All guards must be in position and secure before and during operation.

PRECAUTIONS

LISEZ CE CI AVANT D'OPERER VOTRE COMPRESSEUR

	<div style="background-color: red; color: white; padding: 5px; text-align: center;">  DANGER </div> <p>UN RESERVOIR QUI EXPLOSE CAUSERA LA MORT, BLESSURE SERIEUSE OU DES DOMMAGES DE MATERIAUX</p> <ul style="list-style-type: none"> ● VIDER LE RESERVOIR A AIR APRES CHAQUE UTILISATION POUR PREVENIR UNE ACCUMULATION D'HUMIDITE ET CORROSION QUI CAUSERA LA RUPTURE DU RESERVOIR. ● S'ASSURER QUE LES SOUPAPES DE PRESSION DE SURETE DU RESERVOIR SOIT REGLEES AUX NIVEAUX DE PRESSIONS APROPRIEES. ● NE JAMAIS MODIFIER OU REPARER LE RESERVOIR A AIR. ● NE JAMAIS DEPLACER LE COMPRESSEUR AVEC UN RESERVOIR SOUS PRESSION.
---	---



NE PAS SUIVRE LES PROCEDURES D'OPERATION ET D'ENTRETIEN TELLES Q'INDIQUEES DANS CE MANUEL POURRAIT RESULTER EN UN BRIS D'EQUIPEMENT, BLESSURE PERSONNELLE OU LA MORT. SUIVEZ TOUTES LES PROCEDURES D'ENTRETIEN AUX INTERVALLES INDIQUEES.



NE PAS UTILISER L'AIR DU COMPRESSEUR POUR, LA RESPIRATION OU LE TRAITEMENT D'ALIMENTS. L'AIR DE CE COMPRESSEUR CAUSERA UNE BLESSURE SEVERE OU LA MORT S'IL EST UTILISE POUR LA RESPIRATION OU LE TRAITEMENT D'ALIMENTS.



TOUTE OPERATION D'ENTRETIEN DOIT ETRE EXECUTEE PAR UN PERSONNEL QUALIFIE, UTILISANT LES OUTILS APPROPRIES, LES TORQUES SPECIFIEES ET PIECES DE RECHANGE APPROUVEES.

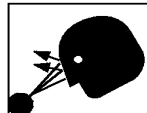

L'HUILE CHAUDE SOUS PRESSION PEUT CAUSER UNE BLESSURE SEVERE OU LA MORT. ARRETEZ LE COMPRESSEUR, LAISSEZ REFROIDIR ET RELACHER LA PRESSION AVANT TOUT ENTRETIEN.



TOUTES COMPOSANTES ELECTRIQUES, CABLES ELECTRIQUES DOIVENT ETRE INSTALLES ET MIS A LA TERRE EN CONFORMANCE AVEC NFPA, LES REGLEMENTS DE SECURITE ELECTRIQUE NATIONAUX ET TOUT REGLEMENT DE SECURITE PROVINCIAL ET LOCAL APPLICABLE.



NE JAMAIS TROP REMPLIR D'HUILE LE COMPRESSEUR. UTILISER LA QUANTITE APPROPRIEE DE LUBRIFIANT DU MANUFACTURIER. REPARER TOUTE FUITE ET NETTOYEZ TOUT DEGAT D'HUILE IMMEDIATEMENT.



AVANT D'ENLEVER UNE PROTECTION OU DE TRAVAILLER SUR LE COMPRESSEUR, DEBRANCHER TOUTE LIGNE DE COURANT ALIMENTANT LE COMPRESSEUR. AFFICHEZ DES PANNEAUX D'ADVERTISSEMENT ET BARRER LES CIRCUITS ELECTRIQUES.



LE COMPRESSEURS PRODUISENT DES TEMPERATURES ELEVEES. NE PAS TOUCHER OU FAIRE CONTACT AVEC CES SURFACES CHAUDES, CAR CELA POURRAIT CAUSER DES BLESSURES PERSONELLES.



TOUTES PROTECTIONS MECANIQUE ET ELECTRIQUE DOIVENT ETRE EN POSITION ET SECURES AVANT ET PENDANT L'OPERATION.

TABLE OF CONTENTS

PARA	TITLE	PAGE
Section 1. SPECIFICATIONS		
	GENERAL	1-1
	SPECIFICATIONS	1-1
	OUTSIDE DIMENSIONS	1-1
Section 2. NOT USED		
Section 3. OPERATION		
	GENERAL	3-1
	OPERATION	3-1
Section 4. MAINTENANCE & PARTS		
	GENERAL	4-1
	ROUTINE MAINTENANCE CHECKLIST	4-1
	AIR COMPRESSOR DA435ELW-PARTS (51713976)	4-2
	AIR COMPRESSOR DA435ELW-DRAWING (51713976)	4-3
	AIR COMPRESSOR DA435ELW-DRAWING (51713976)	4-4
	REPAIR KITS	4-5
	PRESSURE SWITCH KIT (51713977)	4-5
Section 5. REPAIR		
5-1.	GENERAL	5-1
5-2.	PISTON RING REPLACEMENT	5-1
5-3.	OIL PUMP REPLACEMENT	5-2
5-4.	CRANKSHAFT AND BEARING REPLACEMENT	5-4
5-5.	COMPRESSOR DRIVE BELT REPLACEMENT	5-5
5-6.	CLUTCH REPLACEMENT	5-5
5-7.	TROUBLESHOOTING	5-6

SECTION 1. SPECIFICATIONS

GENERAL

The IMT DA435ELW air compressor is a single stage, liquid cooled, 4-cylinder, pressure lubricated unit, with a delivery rate of 35 CFM at 1400 RPM.

The compressor is belt driven from the engine crankshaft, through a magnetic clutch. It is engaged and disengaged by use of an air pressure sensing, electric switch. This pressure switch is preset at approximately 90 PSI to engage, and 130 PSI to disengage.

CAUTION

OPERATING THE COMPRESSOR AT 35 CFM WITH PRESSURES GREATER THAN 130 PSI WILL SHORTEN THE SERVICE LIFE AND VOID THE WARRANTY.

The compressor must not operate more than 6 minutes out of a 10 minute period. This will include operating continuously for 6 minutes out of 10 minutes or operation in segments for a total of 6 minutes out of 10 minutes.

SPECIFICATIONS

Bore	2-5/8"
Stroke	2-1/2"
Cylinder Configuration	V4
Displacement	44 CFM*
Delivery	35 CFM*
Lubrication	Oil Pump
Oil Capacity	1-1/3 qts
Cooling	Water
Height	13-1/2"
Width	15"
Length	13-7/8"
Material	Aluminum Alloy
Weight	87 lbs.

* @ 1400 RPM - 100 PSI

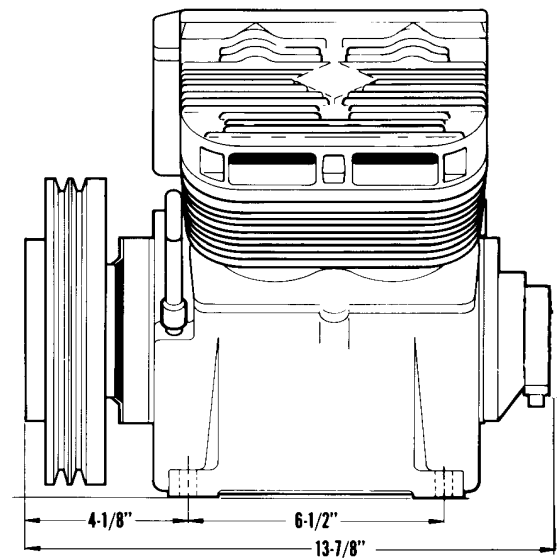
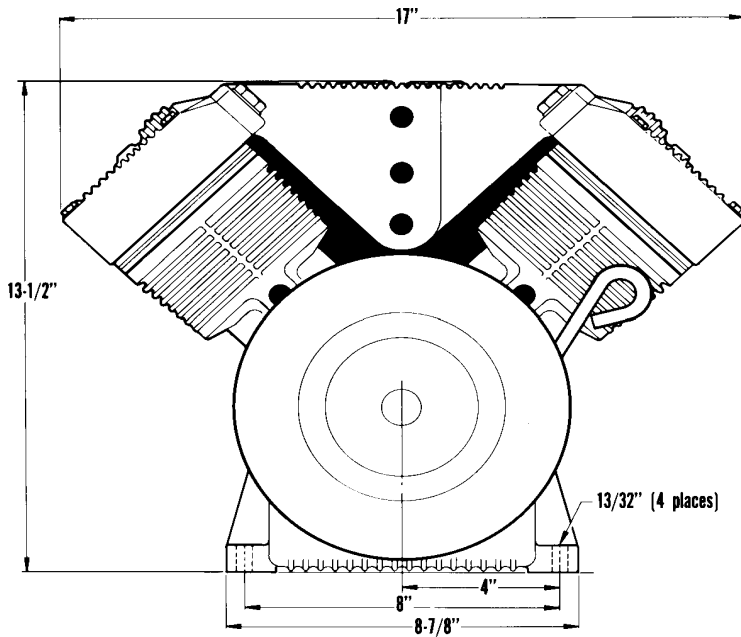

OUTSIDE DIMENSIONS

SECTION 3. OPERATION

GENERAL

Each compressor is bench tested under load at the factory to ensure proper break-in and operation. While it is not necessary to follow any break-in procedure, the following checks should be made before putting the unit into service, as well as, periodically during use.

Before start-up:

1. Check the oil level in the compressor crankcase with the dipstick on the unit. If oil is needed, use only IMT's synthetic compressor oil.
2. Check the air intake filter pads on each head to make certain that they are clean and unobstructed. Dirty filters are a possible cause of reduced air output. Bi-weekly checks of air filters is recommended.

OPERATION

The system will function automatically. It will engage the compressor clutch when the air receiver tank pressure is below 90 psi, and disengage the clutch when the air pressure reaches 130 psi.

CAUTION

OPERATING THIS UNIT IN EXCESS OF 1400 RPM, WILL VOID THE WARRANTY, AND WILL SHORTEN THE NORMAL SERVICE LIFE OF THE COMPRESSOR.

Section 4. MAINTENANCE & PARTS

GENERAL

The following table is a list of routine maintenance items, including service intervals. It also includes a parts list and assembly drawing of the compressor.

MAINTENANCE OPERATION	SERVICE INTERVALS			
	DAILY	WEEKLY	250/3	500/6
AIR INTAKE - INSPECT AND CLEAN				
CRANKCASE OIL LEVEL - CHECK, ADD IF NEEDED				
CRANKCASE OIL - CHANGE (SEE NOTE 1)				
CHECK CYLINDER HEAD BOLT TORQUE (SEE NOTE 2)				
COOLING VANES (FINS) - CLEAN				
SAFETY VALVES - CHECK OPERATION				
SAFETY VALVES - CLEAN				
BELT TENSION - CHECK				
ELECTRIC CLUTCH - CHECK OPERATION				
AIR RECEIVER - DRAIN CONDENSATION				
RECEIVER SAFETY VALVES - CHECK OPERATION				
TIGHTEN AND CHECK ALL VALVES				
CHECK ALL ELECTRICAL CONNECTIONS				
CHECK FITTINGS AND AIR LINES FOR LEAKS				
INSPECT CHECK VALVES FOR PROPER OPERATION				
INSPECT CHECK VALVES FOR CARBON BUILDUP				

Service intervals are listed as hours/months, whichever occurs first.

Use only IMT's synthetic compressor oil. The use of any other oil causes excessive carbon buildup, and will void the warranty on the compressor.

NOTE 1. Under normal operating conditions, oil changes are required every 3 months. When operating in a dirty environment, change the oil more frequently as your particular operating conditions dictate. Oil capacity is 1-1/3 quarts.

NOTE 2. Cylinder head bolt torque MUST be checked after the initial 8-10 hours of operation. The compressor must be cold (room temperature) before retorquing of bolts. Torque bolts to 180 in-lbs plus or minus 10 in-lbs.

ROUTINE MAINTENANCE CHECKLIST

**DA435ELW AIR COMPRESSOR
(51713976-1)**

CONTINUED

ITEM	PART NO.	DESCRIPTION	QTY	ITEM	PART NO.	DESCRIPTION	QTY
1.	60025012	CRANKCASE (PART OF 94)	1REF	56.	77044419	COIL	1
2.	60025194	CYLINDER BLOCK	2	57.	76039119	SEAL (PART OF 91)	1REF
3.	60250270	CYLINDER HEAD	2	58.	60025007	FRT BRG HSG (PART OF 91)	1REF
4.	60025193	PULSATION TANK	1	59.	70055011	FRT BRG CUP (PART OF 91)	1REF
5.	70733069	REED VALVE ASM	2	60.	70055012	FRT BRG CONE PART OF 93)	1REF
6.	73073030	DIPSTICK	1	61.	60108748	CRANKSHAFT (PART OF 93)	1REF
7.	70014613	DIPSTICK TUBE	1	62.	72066267	WOODRUFF KEY #6	1
8.	60120238	OIL SCREEN TUBE (PART OF 94)	1REF	63.	70055009	REAR BRG CONE (PART OF 93)	1REF
9.	60120289	OIL SCREEN (PART OF 94)	1REF	64.	60101269	OIL PUMP COLLAR (PART OF 93)	1REF
10.	72066008	OIL SCREEN CLAMP (PART OF 94)	1REF	65.	72066307	DRIVE PIN (PART OF 93)	1REF
11.	72053090	PIPE NIPPLE 1/2NPT X CLOSE	1	66.	70055010	REAR BRG CUP (PART OF 92)	1REF
12.	51705310	BREATHER CAP ASM(INCL:95,96)	1	67.	60025005	REAR BRG HSG (PART OF 92)	1REF
13.	72063050	WASHER 5/16 LOCK (PART OF 94)	5REF	68.	70014583	COIL SPRING	1
14.	72053403	PLUG 3/8NPT SH (PART OF 94)	1REF	69.	60101505	SLEEVE	1
15.	72053413	PLUG 3/8NPT SQHD (PART OF 94)	1REF	70.	70051006	OIL PUMP	1
16.	70039300	IDENTIFICATION PLATE	1	71.	60250501	PUMP COVER	1
17.	72063001	WASHER 1/4 FLAT	12	73.	72053411	PIPE PLUG 1/8NPT SQHD	2
18.	70014626	AIR INTAKE RETAINER	8	74.	72060731	CAP SCR 5/16-18X3/4 SH (PART OF 94)	5REF
19.	76393803	AIR INTAKE FILTER	8	75.	72060731	CAP SCR 5/16-18X3/4 SH	4
20.	72062001	NUT 5/16-18 HEX	12	76.	51029283	CONNECTING ROD	4
21.	72060063	CAP SCR 7/16-14X1-1/4 HHGR5	4	77.	51029285	PISTON ASM (INCL:78,79,100)	4
22.	72062036	NUT 5/16-24 HEX	12	78.	70014627	WRIST PIN (PART OF 77)	4REF
23.	76039111	GASKET	2	79.	72066018	RETAINING RING (PART OF 77)	8REF
24.	72053403	PIPE PLUG 3/8NPT SH	6	80.	70014600	OIL RING (PART OF 88)	4REF
25.	70024122	WASHER 5/16 FLAT COPPER	12	81.	70014599	COMPRESSION RING(PART OF 88)	8REF
26.	72063052	WASHER 7/16 LOCK	4	82.	76039092	GASKET-REAR BRG .006	2AR
27.	72063050	WASHER 5/16 LOCK	1		76039094	GASHET-REAR BRG .010	2AR
28.	72063001	WASHER 1/4 WRT	2		76039144	GASKET-REAR BRG .020	2AR
29.	72060005	CAP SCR 1/4-20X1-1/4 HHGR5	2		76039143	GASKET-REAR BRG .015	2AR
30.	72053404	PLUG 1/2NPT SH	1	83.	76039093	PUMP COVER GASKET	1
31.	7Q072212	O-RING	8	84.	76039112	FRT BRG HSG GASKET	2REF
32.	76392642	HEAD GASKET	2	87.	72060025	CAP SCR 5/16-18X1HHGR5 (PART OF 94)	5REF
33.	76392641	GASKET-CYL/VALVEPLATE	2	88.	51014947	RING SET (INCL:80,81)	1
34.	76392119	GASKET-CYL/SPACER	2	91.	51705709	FRT BRG HSG (INCL:57-59) (PART OF 94)	1REF
35.	70029293	SPACER-CYL BLOCK	2	92.	51705710	REAR BRG HSG (INCL:66,67) (PART OF 94)	1REF
36.	60106933	CAP	2	93.	51705661	CRANKSHAFT ASM(INCL:60,61,63-65) (PART OF 94)	1REF
37.	72063049	WASHER 1/4 LOCK	2	94.	51714001	CRANKSHAFT/CASE ASM	1
38.	72066537	CABLE CLAMP	2	95.	60107276	CAP-MODIFIED (PART OF 12)	1REF
39.	70394571	PLUG	2	96.	70048080	BREATHER (PART OF 12)	1REF
40.	72661487	DRIVE PIN	3	97.	51714023	INSERT ASM (INCL:42-44,98,102)	REF
41.	76393107	O-RING	2	98.	70029468	SHIM (PART OF 97)	2REF
42.	72066426	BALL (PART OF 97)	2REF	99.	70039124	DECAL-OIL FILL	1
43.	70029593	INSERT (PART OF 97)	2REF	100.	70029062	PISTON (PART OF 77)	4REF
44.	7Q073017	O-RING (PART OF 97)	2REF	101.	72601060	STUD 5/16-24X2 NC GR5	12
45.	72601708	STUD 5/16-18X3-1/2	12	102.	76393085	O-RING (PART OF 97)	2REF
53.	76392550	FOAM FILTER	4				
54.	70732444	CLUTCH HARDWARE	1				
55.	70056437	PULLEY-1 GROOVE .63"	REF				
	70056304	PULLEY-2 GROOVE .50"	REF				
	70056441	PULLEY-6 GROOVE SERPENTINE	REF				
	70056442	PULLEY-7 GROOVE SERPENTINE	REF				

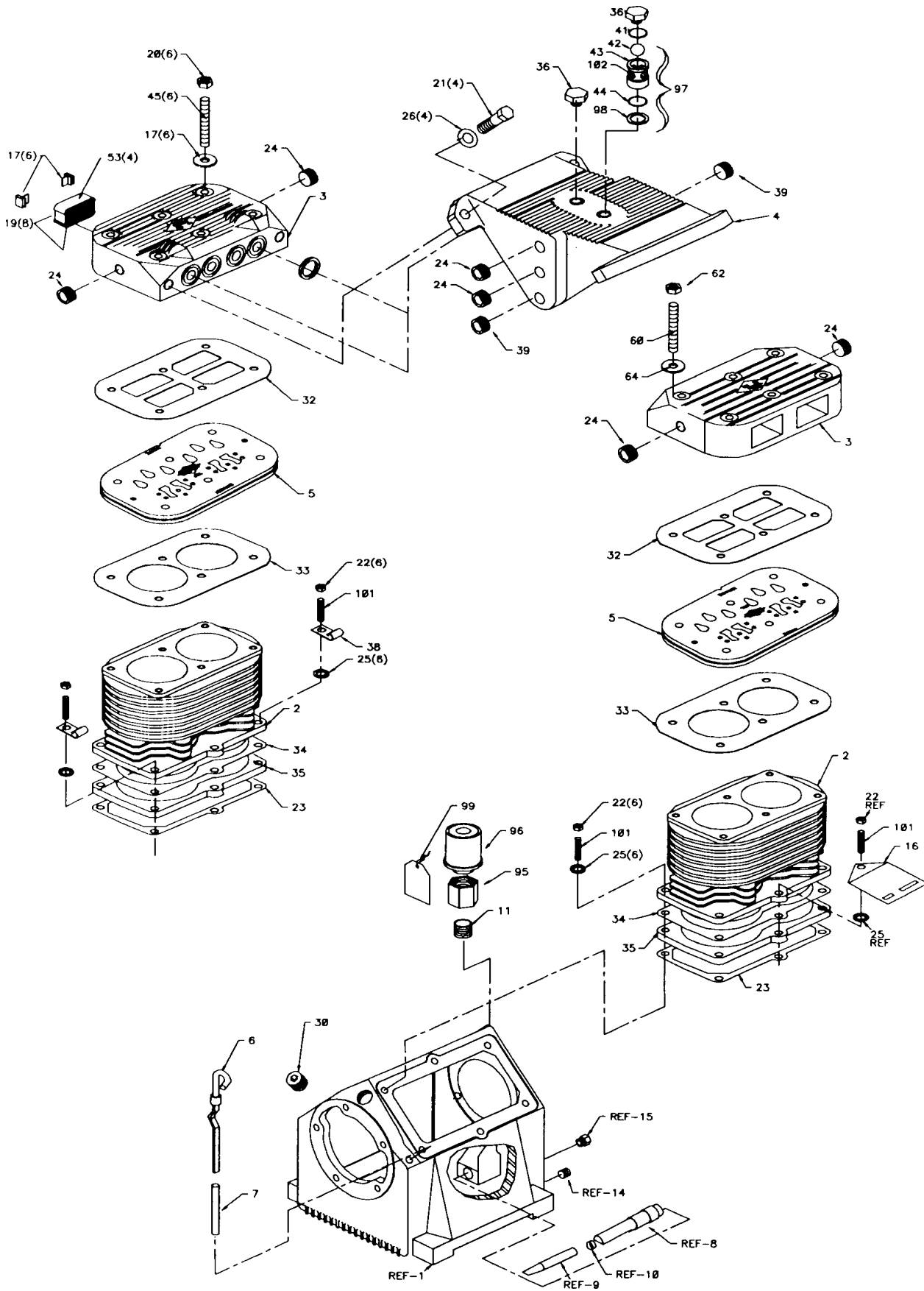

DA435ELW AIR COMPRESSOR (51713976-3)

NOTE

INSTALL PIN (40) INTO COVER (71) WITH GROOVED
END OF PIN PLACED INTO COVER.

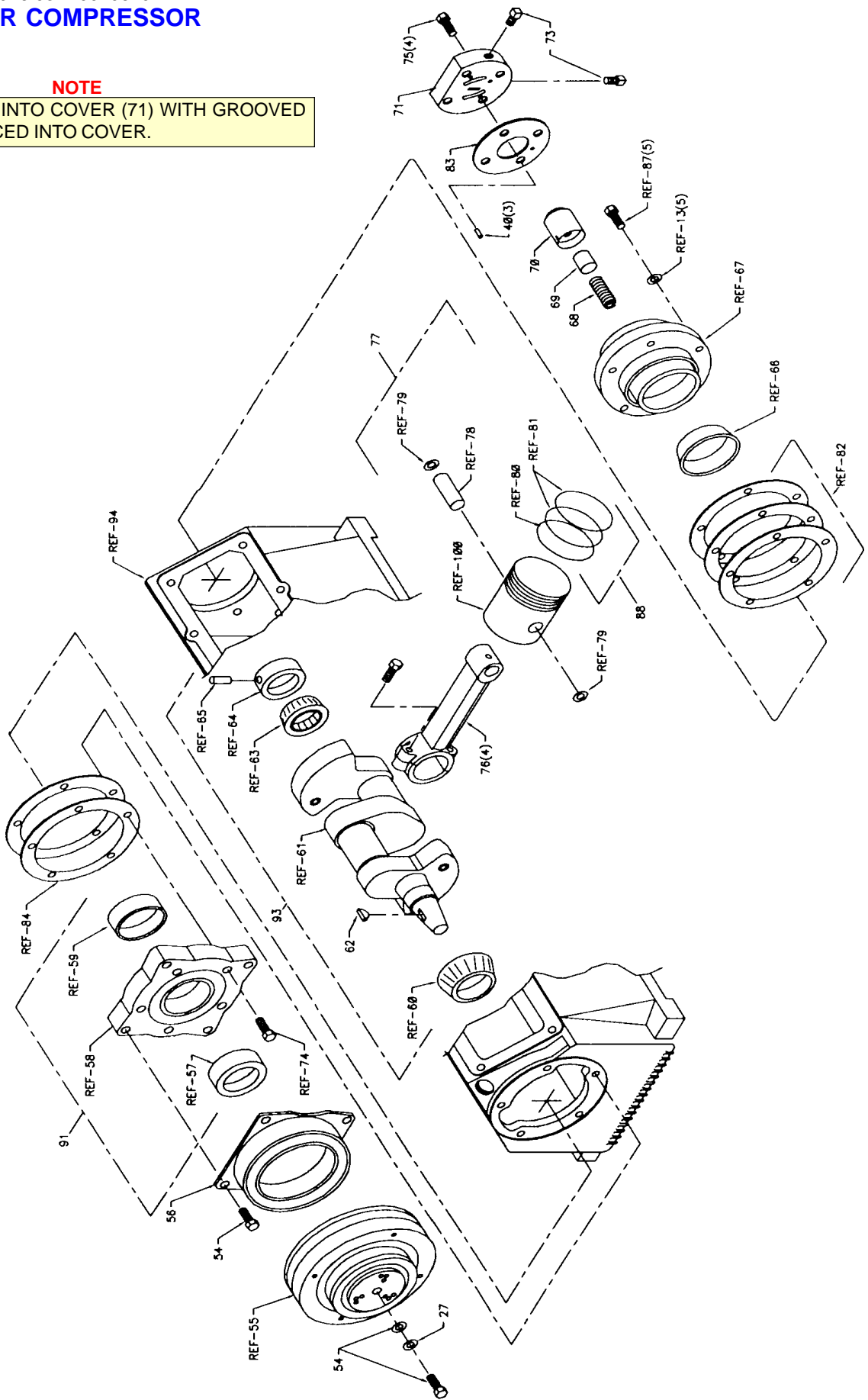

REPAIR KITS

GASKET KIT - 51393640

7Q072212	O-RING - CYL HEAD	8
76039092	GASKET-REAR BRG HSG .006	2
76039093	GASKET-PUMP COVER	1
76039094	GASKET-REAR BRG HSG .010	2
76039111	GASKET-CYL BLOCK BOTTOM	2
76039112	GASKET-FRT BRG HSG	2
76039119	SEAL	1
76039143	GASKET-REAR BRG HSG .015	2
76039144	GASKET-REAR BRG HSG .020	2
76392119	GASKET-CYL BLOCK	2
76392642	GASKET-REED VALVE/HEAD	2
76392641	GASKET-REED VALVE/CLY	2

CRANKSHAFT KIT - 51705743

51705742	CRANKSHAFT ASM	1
51705661	CRANKSHAFT MACH	1REF
72066297	WOODRUFF KEY	1REF
70055010	BEARING-REAR CUP	1
70055011	BEARING-FRT CUP	1
70055012	BEARING-FRT CONE	1REF
70055009	BEARING-REAR CONE	1REF
72066307	DRIVE PIN	1REF
60101269	OIL PUMP COLLAR	1REF

PISTON RING SET - 51014947

70014599	COMPRESSION RING	8
70014600	OIL RING	4

PRESSURE SWITCH KIT (51713977)

ITEM	PART NO.	DESCRIPTION	QTY
1.	77041532	PRESSURE SWITCH	1
2.	72532952	BRASS INSERT	4
3.	89034176	AIR LINE 1/4" (10 FT)	1
4.	72531827	REDUCER BUSHING 3/8-1/2NPT	2
5.	72531042	ELBOW 1/8-1/4NPT 90°	3

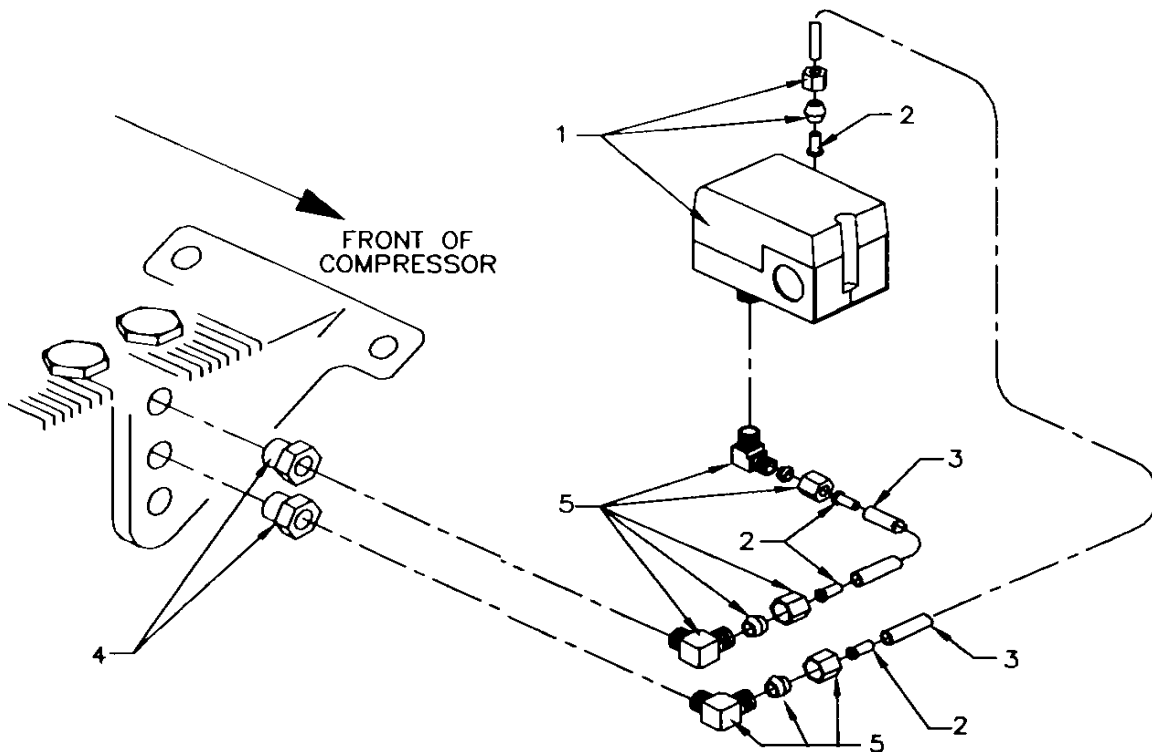

SECTION 5. REPAIR

5-1. GENERAL

This section describes the disassembly and assembly procedures for the air compressor. In all cases, remove the compressor from the welder before proceeding with disassembly. Refer to the parts drawing in section 4 of this manual for parts locations.

5-2. PISTON RING REPLACEMENT

1. Remove the pulsation tank.
2. Unscrew the head bolts and remove the heads.

NOTE

A RUBBER FACED Mallet will help when removing the head. Tap the sides of the head carefully until the head is loose. Lift off the heads.

3. Remove the cylinder bolts. Tap the sides of the cylinder several times to break it loose from the gasket. Rock the cylinder back and forth and lift until it is free. Lift it off the pistons.

4. Use a single edged razor blade, or sharp putty knife, to remove the old gasket material.

CAUTION

DO NOT ALLOW THE GASKET MATERIAL TO FALL INTO THE CRANKCASE. DO NOT NICK THE HEAD, CYLINDER, OR CRANKCASE MATING FACES WHILE REMOVING THE OLD GASKET. REMOVE ALL OF THE OLD GASKET MATERIAL TO PROVIDE A SMOOTH, CLEAN SURFACE FOR THE NEW GASKET. FAILURE TO FOLLOW THIS PROCEDURE MAY RESULT IN THE NEED TO RESEAL THE UNIT LATER.

5. Hone the cylinder to break the glaze and to remove the buildup at the top of the cylinders.
6. Measure the inside diameter of the cylinder for roundness and excessive wear. The bore should be 2.625" (0.0025" tolerance). If the bore is oversized, the cylinder must be replaced.
7. With a ring expander, remove the compression and oil rings.
8. With the ring expander, install the new ring kit. Make certain that the oil ring is on the bottom and the beveled inside edge of the compression ring is toward the top of the piston.

9. Position the cylinder base gasket on the crankcase. Use a few drops of oil to hold it in position. Install the cylinder block spacer and gasket on the crankcase.

10. Rotate the rings so that the gaps of the three rings are 120° apart. Lightly lubricate the inside of the cylinder. Rotate the crankshaft so that a piston is at the top of the stroke. Compress the rings with a ring compressor, and slide the cylinder over the piston. Repeat for the other piston.

CAUTION

DO NOT LUBRICATE THE RINGS. USE A LIGHT LUBRICANT, SUCH AS WD-40 ONLY, ON THE CYLINDER WALLS. OILING THE RINGS WILL PREVENT THEM FROM SEATING AND CAUSE EXCESSIVE OIL CONSUMPTION.

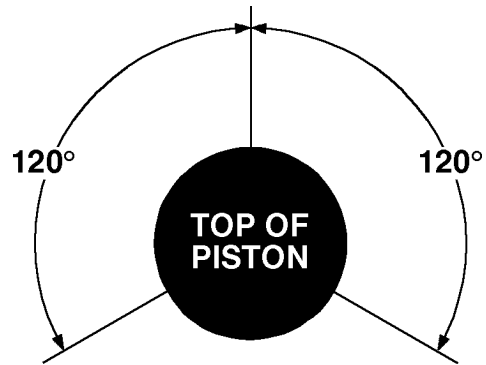

FIGURE E-1. PISTON RING ORIENTATION



FIGURE E-2. CYLINDER HEAD TORQUE SEQUENCE

11. Slide the cylinder down until it mates with the crankcase. Start all cylinder mounting bolts, until they are snug. Torque the bolts to 180 in-lbs in the sequence shown. Do not torque to the full 180 in-lbs all at once. Torque in 25-50 in-lb increments.

NOTE

NO GASKET SEALER IS TO BE USED ON IMT REED VALVE COMPRESSOR GASKETS.

12. Position the gaskets and valve plate on top of the cylinder. Position the head on the cylinder and turn studs finger tight.

NOTE

INSTALL THE REED VALVE PLATE WITH THE IMT LOGO UP AND WORD "EXHAUST" TOWARD THE PULSATION TANK.

NOTE

TO THIS POINT, STUDS SHOULD STILL BE FINGER TIGHT AND NUTS INSTALLED ON STUDS.

13. Push the heads up toward each other and tighten center two nuts on each head to 140 in-lbs (12 ft-lbs).

14. Torque the remaining nuts to 140 in-lbs (15 ft-lbs) per Figure E-2.

15. Install new "O" rings between heads and pulsation tank.

16. Set pulsation tank into place and finger tighten bolts.

17. Cross tighten the pulsation tank to 180 in-lbs (15 ft-lbs).

18. Torque per Figure E-2, all head nuts to 240 in-lbs (15 ft-lbs) plus or minus 10 in-lbs, in 25-40 lb increments.

19. Re-torque after 15 or 20 minutes have passed, per Figure E-2, all head nuts to rating above.

NOTE

YOU MUST DOUBLE CHECK THE TORQUE OF EVERY NUT AND BOLT.

20. Install the compressor, connect the wiring and the air lines.

21. Be sure all tools, welder parts, or anything else loose are removed from compressor before startup. Follow startup procedures listed in owners manual. Test the unit.

CAUTION

REMOVE FINGERS FROM FAN AREA.

22. After 10 hours of operation, wait for unit to cool and re-torque all head bolts to recommended torque shown in Figure E-2.

NOTE

IF PRESSURE FAILS TO BUILD AND THE COMPRESSOR IS EXCESSIVELY NOISY, CHECK THE VALVE PLATE. IT MAY HAVE BEEN INSTALLED UPSIDE DOWN.

5-3. OIL PUMP REPLACEMENT

1. Remove the existing oil pump cover by removing four 5/16" machine head cap screws. A spring behind the oil pump will push the pump partially out as these screws are loosened.

NOTE

BE CERTAIN TO NOTE THE LOCATION OF THE OIL PORT HOLE IN BOTH THE GASKET AND THE COVER. IT IS IMPORTANT THEY ARE ALIGNED WITH THE PORT ON THE CRANKCASE (BOTTOM) FOR RE-ASSEMBLY.

2. With a single edged razor blade, or sharp putty knife, remove the old gasket material. Take care not to damage the machined surfaces.

3. Remove the oil pump so you are able to see inside the rear bearing housing to locate the drive pin. The drive pin should be protruding from the drive collar approximately 1/8".

NOTE

THE NOTCH IN THE OUTSIDE (ROTOR) OF THE PUMP MUST FIT AROUND THIS PIN DURING ASSEMBLY. IF NOT, THE PIN AND/OR PUMP WILL BE DAMAGED WHEN THE CAP SCREWS ARE TIGHTENED.

4. Using a marker, mark the location of the pin on outside of bearing housing. Doing so will assist in alignment of parts at re-assembly. Make certain the crankshaft is not turned after this step.

Re-assemble as follows:

5. To hold the parts in alignment at assembly, screw two 5/16" studs into two diagonal holes in the rear of the bearing housing. Slide the gasket into position, making certain the oil port hole is on the bottom.
6. Hold the pump cover in the vertical position with flat side on top, behind the compressor.
7. Locate the step machined at the front of the oil pump port plate. The pump cover has 2 stop pins and a third pin to prevent incorrect installation. Position these three pins into the machined area.
8. While keeping the port plate in place against the cover, rotate the outside (rotor) of pump to align the notch with the mark for the drive pin, which was applied previously.
9. Slide the pump into the housing and the cover onto the studs up against the pump. Pressure from the spring behind the pump will be noticed.
10. Using even pressure on the cover, attempt to push the cover to make contact with bearing housing. This process may require several attempts with minor adjustments to align all parts.

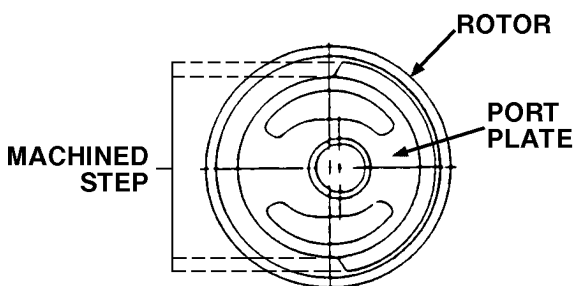

MACHINED STEP LOCATION

13. Once it is possible to make contact with the bearing housing, using hand pressure only, and there remains spring pressure in return, hold the cover tight against the bearing housing using one hand, and screw in two cap screws using the other hand.
14. Do not tighten these two screws until after removing the studs and inserting the other two cap screws.
15. Tighten the cap screws in a criss-cross pattern and torque to 180 in-lbs.
16. Install the air compressor in the welder. Connect the air lines and wiring.

CAUTION

DO NOT RUN COMPRESSOR UNTIL CERTAIN THERE IS OIL PRESSURE. DOING SO WILL SERIOUSLY DAMAGE THE COMPRESSOR

17. Check for oil pressure by removing the 1/4" pipe plug on the side of the pump cover. Very briefly, start the compressor and stop immediately. If oil does not squirt out of this hole in 1 or 2 quick tries, the oil pump may be pinched or misaligned. If so, repeat steps 1-9. If oil pressure is present, replace the pipe plug as the compressor is ready to be run. Check the compressor oil pressure gauge located on the welder's lower control panel. It should move from zero to approximately 50 psi on initial start-up.

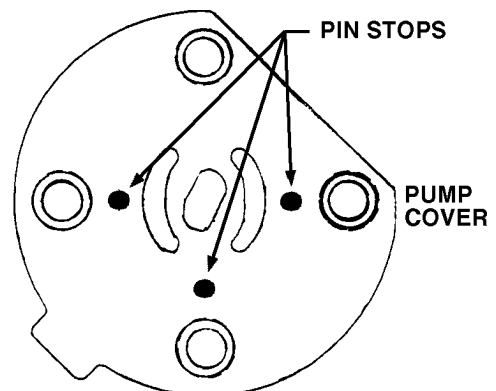

STOP LOCATIONS

5-4. CRANKSHAFT AND BEARING REPLACEMENT

If it is necessary to replace the crankshaft, related components must also be replaced. Replace both bearings, both races, the key, pump collar and pump drive pin.

NOTE

DEPENDING ON THE CONDITION OF THE CRANKSHAFT, BEARING MAY BE REPLACED WITHOUT REPLACING THE CRANKSHAFT. REPLACE THE BEARING RACES WHENEVER THE BEARINGS ARE REPLACED.

1. Remove the pulsation tank, both heads, cylinders, and pistons. Refer to the instructions in section 5, paragraph 2.
2. Remove the bolts on the connecting rods, and lift them out. Reassemble the connecting rods to be certain that the matched parts remain together on the same crankshaft journals.
3. Remove the pump cover, oil pump, sleeve, spring, and rear bearing housing.
4. Remove the clutch and pulley assembly, and the front bearing housing.
5. Pull the crankshaft from the crankcase.
6. Remove all gasket material with a single edged razor blade, or sharp putty knife.

CAUTION

DO NOT GOUGE THE MACHINED SURFACES WHEN REMOVING THE GASKETS. THIS MAY CAUSE LEAKS.

7. Press the bearing races out of the bearing housing.
8. Press the tapered roller bearings off of the crankshaft if only the bearings are being replaced. If the crankshaft is to be replaced, discard the entire assembly.
9. Press the new bearings into position.

NOTE

THE CRANKSHAFT SHOULD HAVE NEW BEARINGS INSTALLED. IF NOT, PRESS THE NEW BEARINGS INTO POSITION ON THE CRANKSHAFT.

10. Generously oil the front bearing race and install the front bearing housing with gasket. Torque the bolts to 180 in-lbs. Torque the bolts as shown in the pattern below.

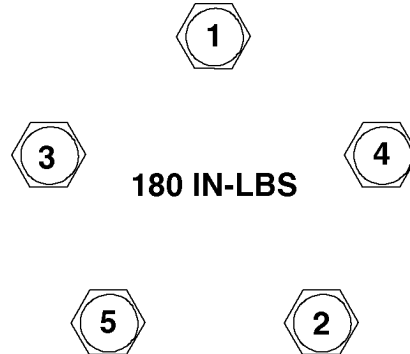

FIGURE E-3. BEARING HOUSING TORQUE SEQUENCE

11. Slide the crankshaft into the crankcase. Generously lubricate the bearing race and install the rear bearing housing and gaskets.

NOTE

GASKET KITS ARE SUPPLIED WITH TWO (2) EACH OF .006, .010, .015, AND .020 GASKETS. USE THESE REAR BEARING GASKETS IN ANY COMBINATION AND QUANTITY TO LIMIT ALL PLAY FRONT TO REAR, BUT STILL ALLOW THE CRANKSHAFT TO TURN FREELY.

12. Install the oil pump as indicated in Section 5-3.
13. Install the connecting rods. Thoroughly oil the crankshaft and rods before installing them. When installing the rods, make certain that the tabs are aligned on the same side of the rod as shown below.
14. Install the pistons, rings, heads and pulsation tank.

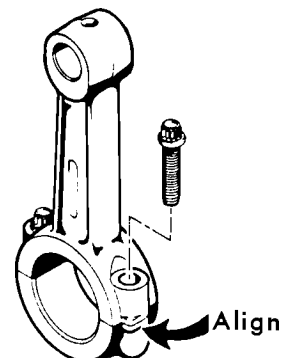

FIGURE E-4. ROD ALIGNMENT

5-5. COMPRESSOR DRIVE BELT REPLACEMENT

CAUTION

BELT IS TENSIONED USING AN AUTOMATIC TENSIONING DEVICE. REMOVE WITH CARE. CAUTION TO ENSURE THE ENGINE WILL NOT ACCIDENTALLY START, DISCONNECT POSITIVE BATTERY CABLE AT BATTERY.

To remove compressor belt:

1. Disconnect positive battery cable at battery.
2. Remove nut and lock washer from lower locking bolt on idler tensioner flange.
3. Loosen center mounting bolt on idler tensioner approximately 1/2 turn.
4. Using a pipe wrench or equivalent tool, turn tensioner body slightly to free locking bolt from tension. If tensioner body cannot be moved using a pipe wrench, loosen bolt by another 1/2 turn. Remove locking bolt and slowly release tension on belt. Remove belt.

NOTE

DO NOT LOOSEN OR REMOVE COMPRESSOR MOUNTING BOLTS. PULLEY MISALIGNMENT MAY RESULT.

To install belt (after following above procedure):

1. Mount belt into pulley grooves and over idler pulley.
2. Using a pipe wrench or suitable tool, turn idler body to realign locking slot in idler flange with locking hole. Insert locking bolt and tighten before releasing idler body. Tighten center mounting bolt.

NOTE

ENSURE THAT BOTH BELT STRANDS ARE RUNNING PROPERLY IN PULLEY GROOVES.

5-6. CLUTCH REPLACEMENT

CAUTION

CLUTCH FAILURE MAY BE DUE TO A LEAKING CHECK VALVE. MAKE CERTAIN THAT THE CHECK VALVES ARE FUNCTIONING PROPERLY BEFORE INSTALLING THE NEW CLUTCH. THE CHECK VALVES MAY BE CHECKED BY PRESSURIZING THE TANK AND SHUTTING OFF THE COMPRESSOR. THERE SHOULD BE NO AIR ESCAPING FROM THE UNLOADER VALVE. IF THERE IS AIR ESCAPING, THE CHECK VALVES ARE FAULTY.

The clutch assembly can be removed while the compressor is still on the welder. The following procedure should be used.

NOTE

DO NOT LOOSEN OR REMOVE COMPRESSOR MOUNTING BOLTS. PULLEY MISALIGNMENT MAY RESULT.

WARNING

ATTEMPTING TO START THE ENGINE WHILE THE CLUTCH IS BEING REMOVED WILL CAUSE SERIOUS INJURY.

1. Remove compressor drive belt. Follow compressor drive belt replacement procedure Section 5-5 for proper removal. Failure to do so could result in serious injury.

CAUTION

BELT IS TENSIONED USING AN AUTOMATIC TENSIONING DEVICE. REMOVE WITH CARE.

2. Electrically engaging the compressor clutch will make for easier removal of clutch pulley.

CAUTION

TO ENSURE THE ENGINE WILL NOT ACCIDENTALLY START, DISCONNECT POSITIVE BATTERY CABLE AT BATTERY.

3. Remove access panel at rear of compressor, below radiator. Open clutch coil wire at in-line insulated connector.

CAUTION

SPRING TENSIONER TENSION MUST BE RELEASED BEFORE ATTEMPTING TO REMOVE PULLEY. FAILURE TO DO SO COULD RESULT IN SERIOUS INJURY. FOLLOW COMPRESSOR DRIVE BELT REPLACEMENT PROCEDURE SECTION 5-5.

CAUTION

DO NOT USE A WHEEL PULLER ON THE OUTER RIM OF THE PULLEY. THIS CAN RESULT IN DAMAGE TO THE CLUTCH BEARING.

DA435ELW: 99900917:19970508

4. Run a jumper wire from the battery positive terminal to the now loose lead coming from the clutch coil. Insulate the connection point from welder frame. This will engage clutch coil.
5. Remove the bolt in the center of the pulley and insert a 5/8-11 bolt.
6. Tighten the 5/8-11 bolt until the pulley is forced off the crankshaft.
7. Remove the pulley and disconnect temporary jumper wire.
8. Remove the four (4) bolts holding the coil assembly to the front of the compressor.

To reinstall the clutch:

1. Position the magnetic coil assembly over the front bearing housing and secure the assembly with the 1/4-20 bolts. Torque to 85-120 in-lbs.
2. Insert the woodruff key into the crankshaft slot.

5-6

3. Slide the pulley, spacer, and lock washer onto the end of crankshaft. Be certain that the pulley slot aligns with the woodruff key. Secure them with the 5/16-18 bolt.
4. Rotate the pulley assembly manually to check for interference between the pulley and the coil. If there is interference, disassemble the clutch and repeat the procedure.
5. Connect a temporary jumper wire from the battery positive terminal to the loose lead from the clutch coil lead.
6. Tighten the center bolt in the pulley.
7. Remove battery jumper at clutch in-line connector. Reconnect clutch coil wire at in-line insulated connector.
8. Install and tighten the drive belts. See compressor drive belt replacement procedure section 5-5.
9. Install access panel (below radiator) and test the unit for proper operation.

5-7. TROUBLESHOOTING

LOW OIL PRESSURE	LOW OIL LEVEL
	LOOSE PIPE PLUG ON OIL PUMP COVER
	WORN OR DEFECTIVE OIL PUMP
	CRACK OR SCRATCH ON OIL PUMP COVER
NO OIL PRESSURE	DEFECTIVE OIL PUMP
	BLOCKED OIL PASSAGE
	DAMAGED OIL PUMP DRIVE PIN
COMPRESSOR WILL NOT ENGAGE	BLOWN FUSE IN PRESSURE SWITCH CIRCUIT
	DEFECTIVE CLUTCH/BELT
	DEFECTIVE PRESSURE SWITCH
COMPRESSOR ENGAGES BUT WILL NOT PRESSURIZE TANK	AIR LEAK IN PLUMBING
	WORN PISTON RINGS OR VALVE PLATES
	DEFECTIVE CHECK VALVE / VALVES
COMPRESSOR DOES NOT RECOVER PRESSURE AS FAST AS IT SHOULD	DEFECTIVE CHECK VALVE / VALVES
	DIRTY FILTERS
	LOOSE DRIVE BELT
	AIR LEAK IN PLUMBING
	WORN VALVE PLATES OR PISTON RINGS

FIGURE E-5. TROUBLESHOOTING CHART

The information within this manual has been compiled and checked but errors do occur. To provide our customers with a method of communicating those errors we have provided the Manual Change Request form below. In addition to error reporting, you are encouraged to suggest changes or additions to the manual which would be of benefit to you. We cannot guarantee that these additions will be made but we do promise to consider them. When completing the form, please write or print clearly. Submit a copy of the completed form to the address listed below.

MANUAL CHANGE REQUEST

DATE	PRODUCT MANUAL	MANUAL PART NO.
SUBMITTED BY		
COMPANY		
ADDRESS		
CITY, STATE, ZIP		
TELEPHONE		

ERROR FOUND

LOCATION OF ERROR (page no.): _____

DESCRIPTION OF ERROR: _____

REQUEST FOR ADDITION TO MANUAL

DESCRIPTION OF ADDITION: _____

REASON FOR ADDITION: _____

MAIL TO: IOWA MOLD TOOLING Co., Inc.
Box 189,
Garner IA 50438-0189
ATTN: Technical Publications

LIMITED WARRANTY - DA435ELW

WARRANTY COVERAGE - The DA435ELW Underhood Air Compressor manufactured by Iowa Mold Tooling Co., Inc. (IMT) is warranted to be free from defects in material and workmanship, under proper use, application and maintenance in accordance with IMT's written recommendations, instructions and specifications as follows:

1. One (1) year; labor on IMT workmanship from the date of shipment to the end user.
2. One (1) year; original IMT parts from the date of shipment to the end user.

IMT's obligation under this warranty is limited to, and the sole remedy for any such defect shall be the repair or replacement (at IMT's option) of unaltered parts returned to IMT, freight prepaid, and proven to have such defect, provided such defect occurs within the above stated warranty period and is reported within fourteen (14) days of its occurrence.

IMPLIED WARRANTY EXCLUDED - This is the only authorized IMT warranty and is in lieu of all other express or implied warranties or representations, including any implied warranties of merchantability or fitness for any particular purpose or of any other obligations on the part of IMT.

WARRANTY CLAIMS - Warranty claims must be submitted and shall be processed in accordance with IMT's established warranty claim procedure.

WARRANTY SERVICE - Warranty service will be performed by any IMT distributor authorized to sell new IMT products of the type involved or by any IMT Service Center authorized to service the type of product involved or by IMT in the event of direct sales made by IMT. At the time of requesting warranty service, the purchaser must present evidence of the date of delivery of the product. The purchaser shall pay any premium for overtime labor requested by the purchaser, any charge for making service calls and for transporting the equipment to the place where warranty work is performed.

WARRANTY VOIDED - All obligations of IMT under this warranty shall be terminated:(1) if service other than normal maintenance or normal replacement of service items is performed by someone other than an authorized IMT dealer, (2) if product is modified or altered in ways not approved by IMT.

PURCHASER'S RESPONSIBILITY - This warranty covers only defective material and workmanship. It does not cover depreciation or damage caused by normal wear, accident, improper protection in storage, or improper use. The purchaser has the obligation of performing the care and maintenance duties discussed in IMT's written recommendations, instructions and specifications. Any damage which results because of purchaser's failure to perform such duties shall not be covered by this warranty. The cost of normal maintenance and normal replacement of service items such as filters, belts, etc. shall be paid by the purchaser.

CONSEQUENTIAL DAMAGES - The only remedies the purchaser has in connection with the breach or performance of any warranty on IMT products are those set forth above. In no event will the dealer, IMT or any company affiliated with IMT, be liable for business interruptions, loss of sales and/or profits, rental or substitute equipment, costs of delay or for any other special, indirect, incidental or consequential losses, costs or damages.

REPRESENTATIONS EXCLUDED - IMT products are subject to no expressed, implied or statutory warranty other than herein set forth, and no agent, representative or distributor of the manufacturer has any authority to alter the terms of this warranty in any way whatsoever or to make any representations or promises, express or implied, as to the quality or performance of IMT products other than those set forth above.

CHANGE IN DESIGN - IMT reserves the right to make changes in design or improvements upon its products without imposing any obligation upon itself to install the same upon its products theretofore manufactured.

Effective November, 1996

This parts manual is provided to the user to assist in servicing the equipment. It is the property of Iowa Mold Tooling Co., Inc and, as such, may not be reproduced either whole or in part, whether by chemical, electrostatic, mechanical or photographic means without the expressed written permission of an officer of Iowa Mold Tooling Co., Inc. One manual is provided with each piece of new equipment and additional manuals may be obtained at a nominal price.



IOWA MOLD TOOLING CO., INC.
BOX 189, GARNER, IA 50438-0189
TEL: 515-923-3711
TECHNICAL SUPPORT FAX: 515-923-2424