

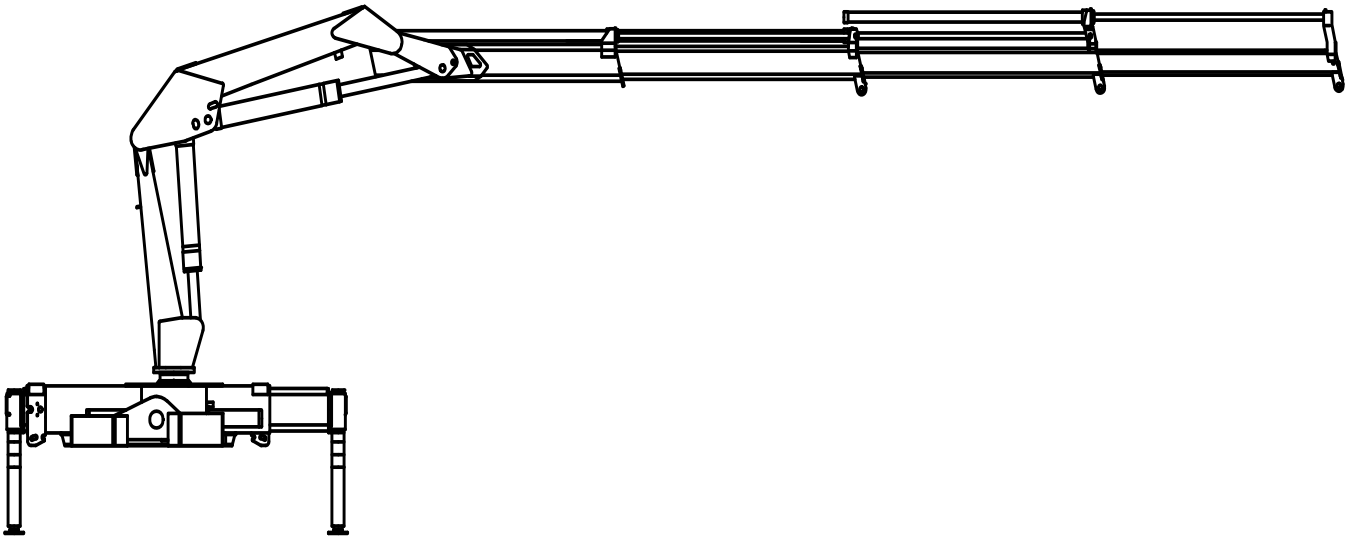

Model 9/63

Instruction Manual



NOTE

Read and understand this manual, the
IMT Operators Crane Safety Manual
and Safety Manual Supplement
before operating or maintaining your crane.

IOWA MOLD TOOLING CO., INC.

BOX 189, GARNER, IA 50438-0189

TEL: 641-923-3711

TECHNICAL SUPPORT FAX: 641-923-2424

Iowa Mold Tooling Co., Inc. is an Oshkosh Corporation company.

Table of Contents

Revisions List 2

1.0 Loader Terminology 3

2.0 General Safety Considerations 3

3.0 Loader Operation 4

3.1 Start-up Preparation 4

3.2 Stabilizer Activation 5

3.3 Unfolding the Loader 5

3.4 Using the Loader 6

3.5 Post Operation 7

4.0 Maintenance 7

4.1 Lubrication Intervals 7

4.2 Lubrication Chart 8

4.3 Recommended Lubricants 8

5.0 Lifting Capacity 8

5.1 Capacity Charts 8

6.0 Technical Data 13

6.1 Dimensional Drawing 13

6.2 Specifications 14

7.0 Working Pressure / Performance 15

8.0 Hydraulic System 16

8.1 Description 16

8.2 Recommended Hydraulic Oil Types 16

8.3 Hydraulic Diagrams 16

9.0 Bleeding of Cylinders 18

10.0 Repair 18

11.0 Service 18

11.1 Initial Service Overhaul 18

11.2 Annual Service Overhaul 19

12. Load Moment Limitation 19

13. Heavy Duty Lifting - HDL 19

14. Hoses and Hydraulic Pipes 19

Revisions List

DATE	LOCATION	DESCRIPTION OF CHANGE
-	-	-
20061113	1	NEW OWNERSHIP STATEMENT
20071112	8-13	ECN 9000 - UPDATED CAP CHART ART, DIMENSIONAL DRAWING & SPECS UPDATED FOR CONSISTENCY
20111201		ECN 11628 - UPDATE STABILIZER WORDING, ELECTROCUTION DISTANCES

1.0 Loader Terminology

The loader is designed as a truck mounted loader and therefore stationary mounting of the loader, mounting on agricultural tractors, special purpose vehicles and the like may only be performed according to specific agreement with IMT.

1. Suspension traverse
2. Control valve, loader
3. Stabilizer beam
4. Extension cylinder
5. Stabilizer leg
6. Control valve, stabilizers
7. Rotation / Slewing cylinder
8. Planetary gear
9. Boom cylinder
10. Base
11. Mast / Column
12. Link arm, boom
13. Hinge pin
14. Main boom
15. Outer / Jib cylinder
16. Outer / Jib pin
17. Link arm, jib
18. Outer boom / Jib
19. Extension
20. Extension cylinder

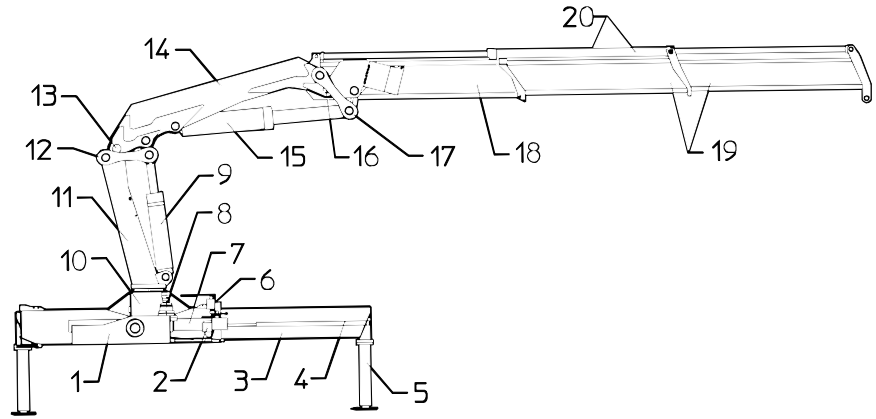

FIGURE 1:LOADER OVERVIEW

2.0 General Safety Considerations

WARNING

Prior to operation, read and understand the IMT Operator's Crane Safety manual and any other safety manuals which accompanied the loader.

General Considerations for Loader Safety and Stability

Prior to starting the loader, the operator must check the following factors:

1. Ground Stability - The ground must be stable enough to withstand the stabilizer leg pressure. Steel plates should be placed beneath the stabilizer foot plates to support heavy lifts.
2. Ground Surface Conditions - The ground must not be slippery (i.e., covered with ice, sand, etc.). When the parking brake is applied, the truck must not skid or move during horizontal pressure from the loader.
3. Visibility - The operator must have a complete and unobstructed view of the field of operation.
4. Overhead Powerlines - The operator must make sure that there are no electric wires or any other obstacles within the working radius of the loader.
5. Unauthorized Entry - The operator must inform any unauthorized persons that entry into the working area is not permitted.

General Rules for Powerlines or Power Supply Stations:

When working in proximity to power supply stations or overhead wires, follow these general rules:

1. Be careful in planning, instructing, and executing work to prevent any risk or danger to persons, equipment or goods.
2. Consider any power supply plant, installation or wire live until proven otherwise.
3. Follow any and all directions or guidelines from the responsible power supply authorities .

Any person or company directly responsible for the implementation of work in the proximity of overhead wires or electric power stations must make sure that all personnel involved in the execution of such work is familiar with any laws, rules or safety regulations.

**FIGURE 2:
DECAL - DANGER,
ELECTROCUTION**

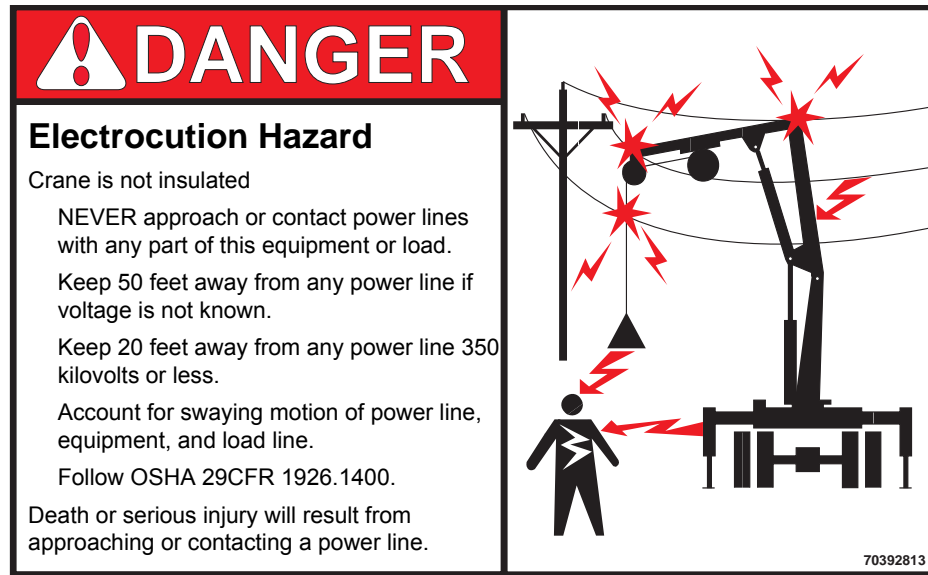

3.0 Loader Operation

3.1 Start-up Preparation

I. Switch the hydraulic change-over valve to the “loader” position.

II. Engage the PTO at low revolutions. The engine revolution speed is regulated via the hand accelerator to ensure that the oil flow from the hydraulic pump corresponds to the recommended pump flow for the loader. If starting the loader in cold weather, the oil should circulate for a few minutes before operation starts.

III. Apply the vehicle parking brake.

IV. RCL System - Prior to setting the stabilizers or starting loader operations, the RCL (rated-capacity limitation) system must be activated. To activate the RCL system, pull out the emergency stop button(s). Push the green button once. The “RUN” diode on the RCL system control panel (Figure 3) is lit and the RCL safety system is activated.

RUN ○	1	○ FUNC
100% ○		○ F1
95% ○	2	○ P1 F2
90% ○		○ P2 F3
85% ○	3	○ F4
80% ○		○ F5



FIGURE 3: RCL 5100 CONTROL PANEL

3.2 Stabilizer Activation

I. To activate the stabilizer function, push the yellow button. The “FUNC” and “F5” diodes are lit. After 10 seconds the diodes are turned off, but the stabilizer function remains activated.

II. To set the stabilizers, release the stabilizer lock and extend the stabilizer beam completely. **LOCK IT AGAIN.** The stability of the vehicle and the loader is based on the stabilizer legs being fully deployed, and the loader should only be used when the stabilizers are fully deployed. The operator must make sure that the vehicle has sufficient stability in the area in front of the stabilizers (over the cab). The stabilizers should be lowered just enough to raise the truck chassis slightly, while keeping the tires in full contact with the ground.

**FIGURE 4:
STABILIZER LOCK**

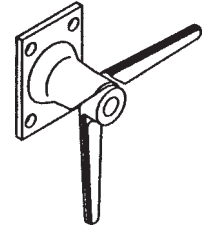

When loading the truck, the operator must raise the stabilizer legs periodically to ensure that the truck and not the stabilizers carry the weight. The stabilizer legs are not designed to support a fully loaded truck.

III. Position the vehicle as close to horizontal as possible. Use the stabilizers if necessary to achieve horizontal positioning if the ground is not level.

IV. Use plates (steel) beneath the stabilizer legs if the ground cannot support the stabilizer leg pressure.

3.3 Unfolding the Loader

I. Extend stabilizer beams fully and engage swivel locks.

II. Lower the stabilizer legs.

III. Lower the outer boom slightly to release it from the bracket.

IV. Raise the inner (main) boom to release it from the bracket. Raise the inner (main) boom about 10° above horizontal so that the outer boom can be moved freely downwards.

V. Raise the outer boom (jib) until it is free from the base.

VI. If the loader is equipped with a stop bracket on the outer boom, extend the extension booms until the stop bracket is released.

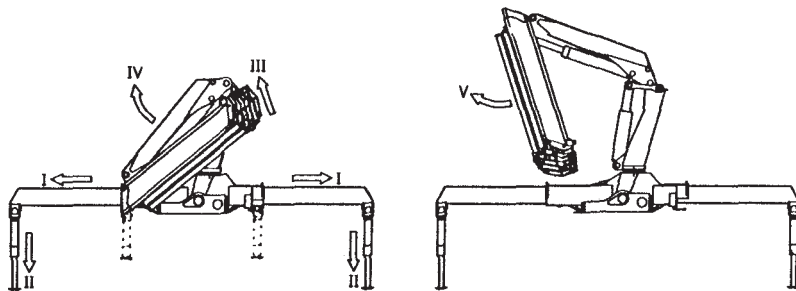

FIGURE 5: UNFOLDING A KNUCKLE-BOOM CRANE

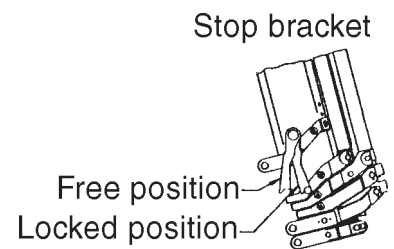

FIGURE 6: STOP BRACKET

3.4 Using the Loader

Loader Valve Bank Activation

To activate the loader working functions, move one of the control levers of the loader’s control valve OR Push the yellow button twice. “FUNC” is lit and “F5” is turned off.

Now the loader functions can be operated using the control valves. Each control valve is labeled with the functions of that particular valve. See Figure 7 for the control valve functions. Operate the control levers steadily and smoothly to avoid unnecessary strain on the loader.

FIGURE7: CONTROL VALVES

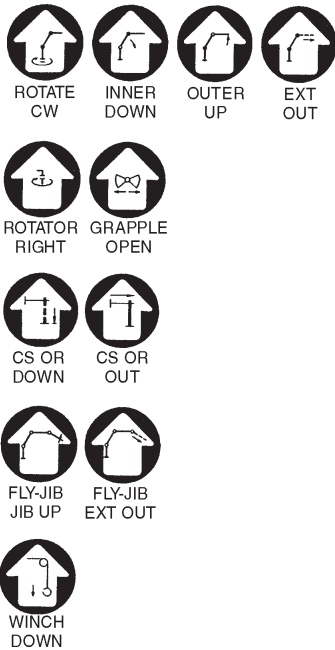

The lifting capacity of the loader is shown on the Capacity Chart on the loader and in this instruction manual. Never exceed the indicated capacity limits.

The loader is designed to lift loads vertically. Diagonal stress must be avoided. Do not drag loads across the ground using the extension cylinders or the rotation system. Activate these functions when the load is free of the ground.

When mounting a grapple, the total weight (grapple, rotator, and contents) must not exceed the lifting capacity of the loader at maximum reach. The grapple may be used to move soil only. It must not be used to excavate earth.

If the load is extended so far that the lifting capacity is exceeded, the load moment increasing movements will be stopped. See the RCL Safety System Instruction Manual.

WARNING

Never stand under the boom when the loader is working.

NOTES FOR SAFE OPERATION:

Position the truck as closely to the load as possible to lift the load on the shortest possible boom.

Operate the rotation system carefully, especially when the inner boom is at an acute angle to the outer boom.

Do not activate the stabilizers when the loader is working.

Never drive off with a suspended load.

3.5 Post Operation

To stow the loader, reverse the procedure in Section 3.3, *Unfolding the Loader*. If the boom is parked on the truck platform, it must be properly secured so it does not swing out during transport. The total height should not exceed 13'6" per Federal Highway Regulations.

If the loader is equipped with swing-up stabilizer legs, they must also be secured in position before driving off.

Before starting the vehicle, disengage the PTO. This turns off the pump.

4.0 Maintenance

Regularly check the items below on the loader. Log the inspection in the IMT Crane Log included with the manual.

1. The oil level in tank and rotation system. Oil must be visible in the oil level glass of the tank when the loader is folded. If the loader is equipped with a planetary gear, check its oil level.

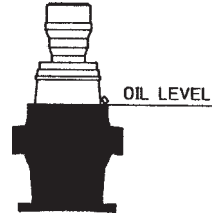

2. Check for defects, damage or leaks . If found, take the loader to an authorized IMT service center for repair as soon as possible.

FIGURE 8: OIL LEVEL

3. Check the loader to truck mounting hardware.

4. Slide blocks and bushings reduce friction and therefore they are naturally subject to wear. Slide blocks should be replaced when slack is detected in the boom system. Bushings should be replaced before the metal components physically touch each other.

5. Check all hoses for defects and kinks.

6. Check that hooks, straps and safety latches are in good working order.

7. Check all lock pins and bolts for wear.

4.1 Lubrication Intervals

Pinion of mast/Planetary gear (if any):

after 50 hours of operation/1 month (whichever occurs first)

Base bearings:

after 20 hours of operation/1 week (whichever occurs first)

Extension system/Slide blocks:

after 50 hours of operation/1 month (whichever occurs first)

Guide rail on extension cylinders:

after 50 hours of operation/1 month (whichever occurs first)

Pin connections/Bolts:

after 50 hours of operation/1 month (whichever occurs first)

Stabilizer beams:

as required

Control valves and rod connections (Oil spray):

as required

4.2 Lubrication Chart

FIGURE 9: LOADER LUBRICATION POINTS

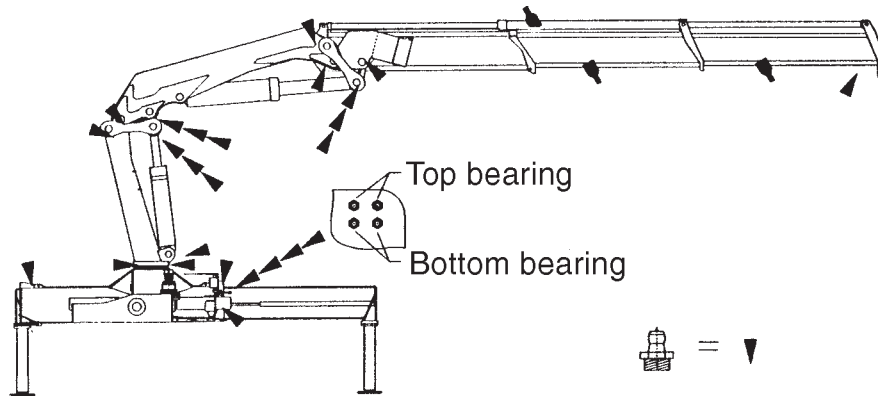

When lubricating the bearings in the base, activate the rotation system and swing the loader from stop to stop within the entire rotation area.

Lubricate the telescopic extensions and planetary gear are lubricated with a special grease (Statoil Grease Way CaH or Castrol ALV).

CAUTION

If the loader is not folded after use, retract all cylinders at least once per day to avoid corrosion on the piston rod surface.

4.3 Recommended Lubricants

Grease Brand	Grease for Bearings
BP	Energrease L52
Castrol	LM Grease
ESSO	MP Grease I Beacon EP 2
Mobil	Mobilux EP 2 or Mobilgrease HP
Shell	Retinox MS
Statoil	Uni Way EP 2
Texaco	Multifak All Purpose EP 2

Grease containing molybdenum disulphide must not be used.

Grease Brand	Grease for Telescopic Extensions
Statoil	Grease Way CaH 92
Castrol	ALV

5.0 Lifting Capacity

5.1 Capacity Charts

The loader is marked with factory-installed lifting capacity decals. These decals must be intact and legible. If the decal has been damaged or removed, order a new decal from IMT using the part number from the decal or consult the parts manual, decal kit.

As a supplement to the loader’s lifting capacity decals, the following pages contain load and lifting capacities of the different K-versions in standard applications. Special applications and customized decals and options are not shown.

WARNING

Never exceed the lifting capacity limits.

IMT
MATERIAL HANDLING SYSTEMS

IOWA MOLD TOOLING CO., INC.
BOX 189 • GARNER • IA • 50438 • 641-923-3711

**Model
9/63K1**

- Working loads will be limited to those shown. Deduct the weight of load handling devices.
- Before lift is made, stability must be checked per SAE J765A.

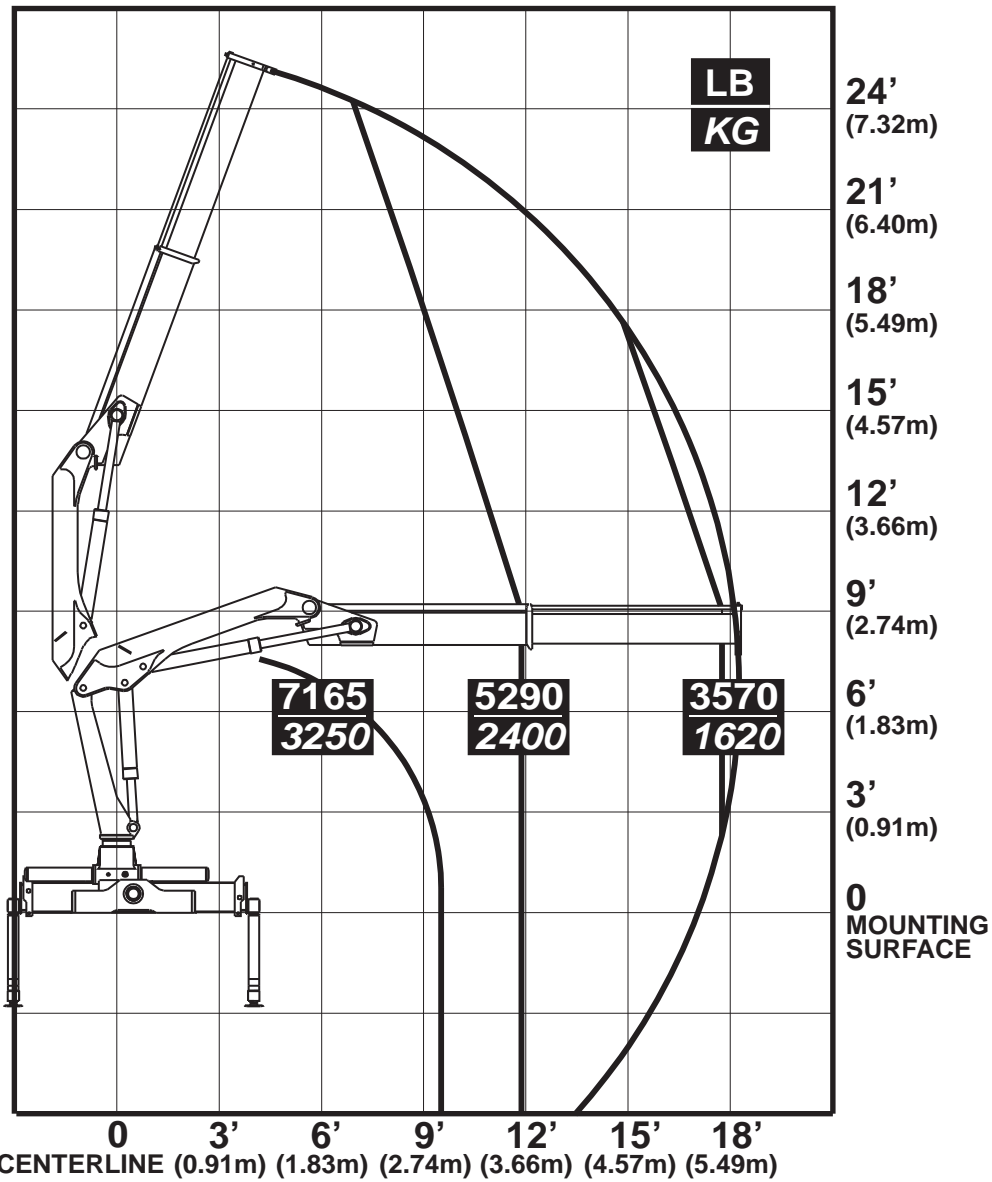

70395973

IMT
MATERIAL HANDLING SYSTEMS

IOWA MOLD TOOLING CO., INC.
BOX 189 • GARNER • IA • 50438 • 641-923-3711

**Model
9/63K2**

- Working loads will be limited to those shown. Deduct the weight of load handling devices.
- Before lift is made, stability must be checked per SAE J765A.

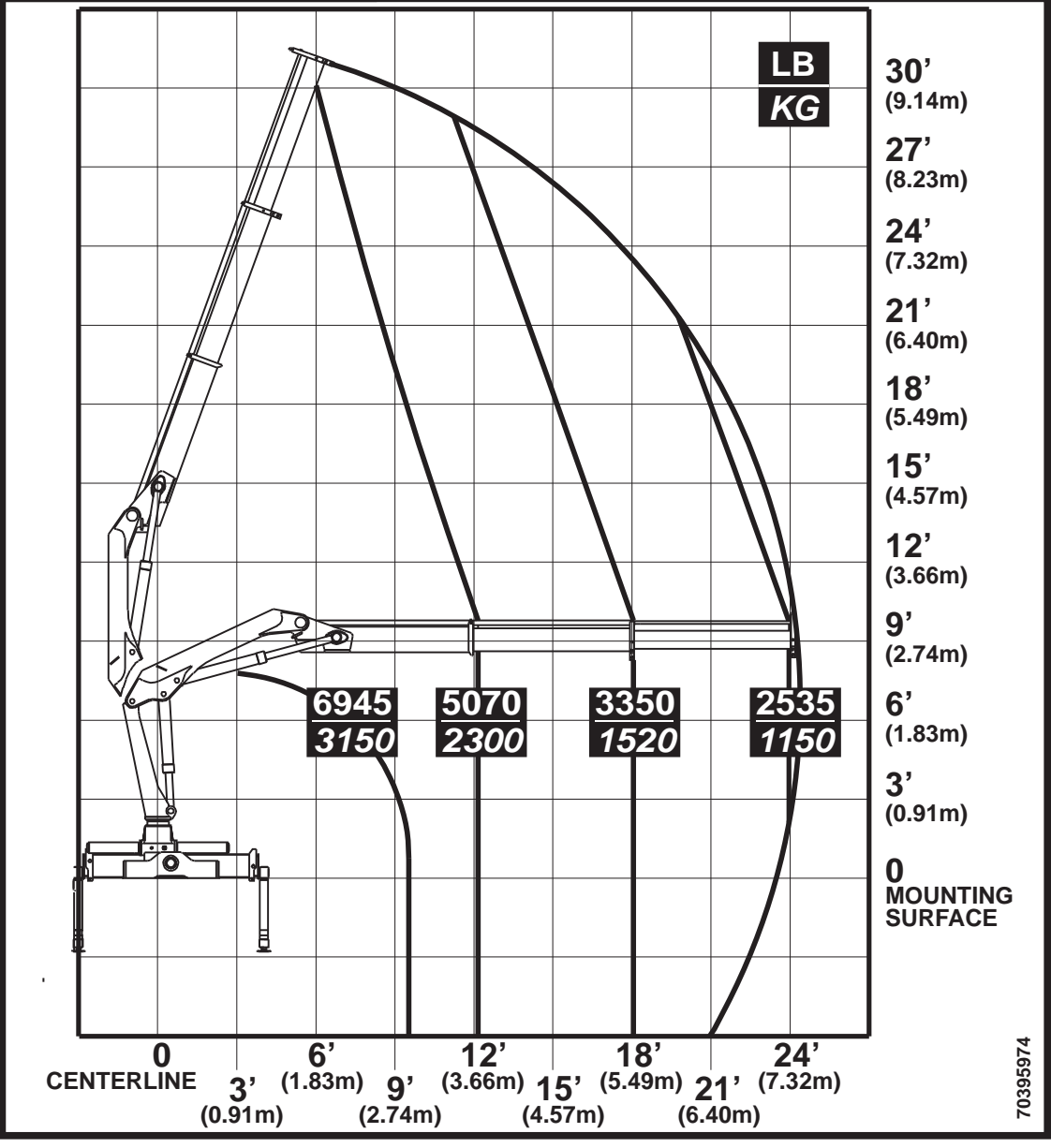

70395974

IMT
MATERIAL HANDLING SYSTEMS

IOWA MOLD TOOLING CO., INC.
BOX 189 • GARNER • IA • 50438 • 641-923-3711

Model 9/63K3

- Working loads will be limited to those shown. Deduct the weight of load handling devices.
- Before lift is made, stability must be checked per SAE J765A.

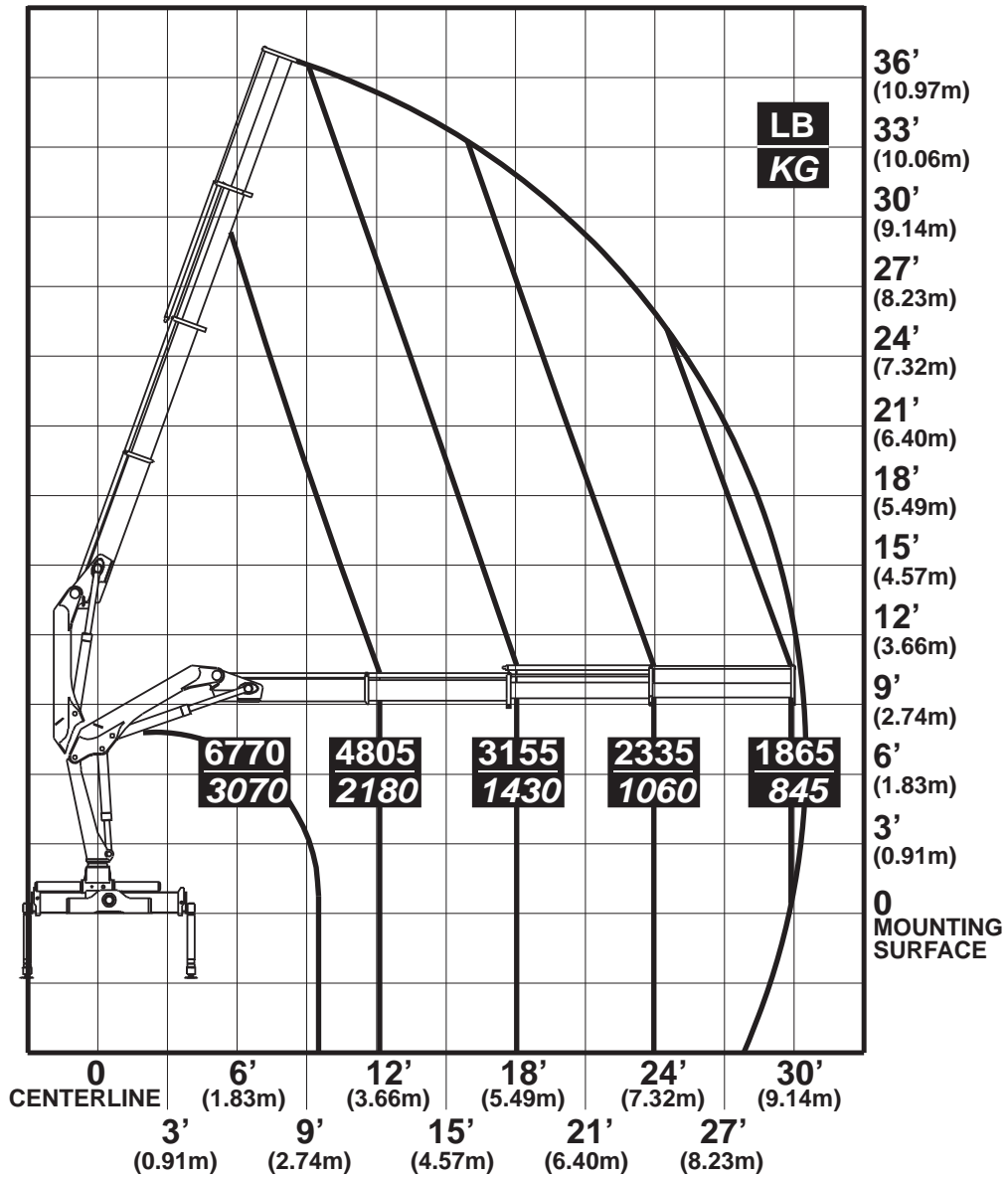

70395975

IMT
MATERIAL HANDLING SYSTEMS

IOWA MOLD TOOLING CO., INC.
BOX 189 • GARNER • IA • 50438 • 641-923-3711

Model 9/63K4

- Working loads will be limited to those shown. Deduct the weight of load handling devices.
- Before lift is made, stability must be checked per SAE J765A.

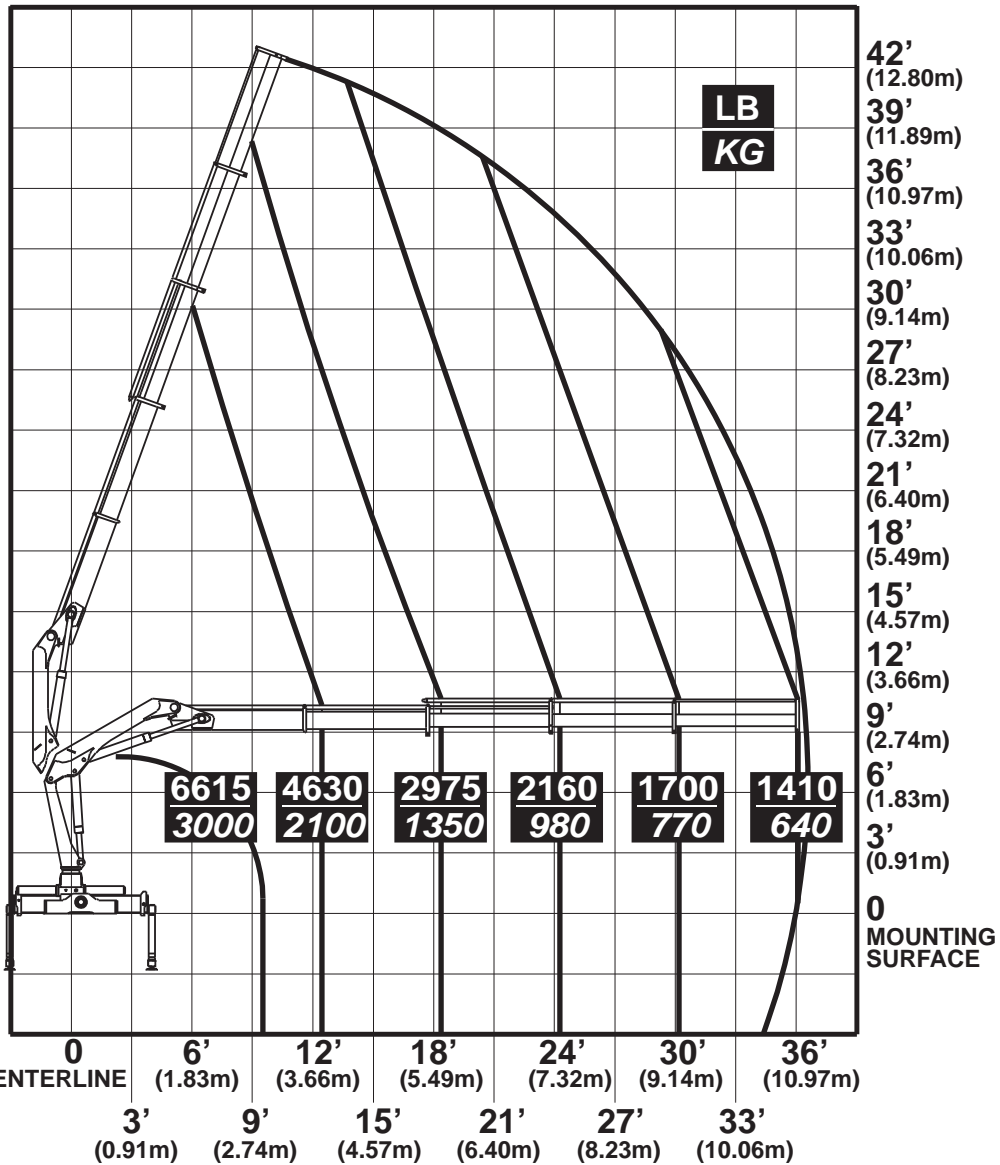

70395976

6.0 Technical Data

6.1 Dimensional Drawing

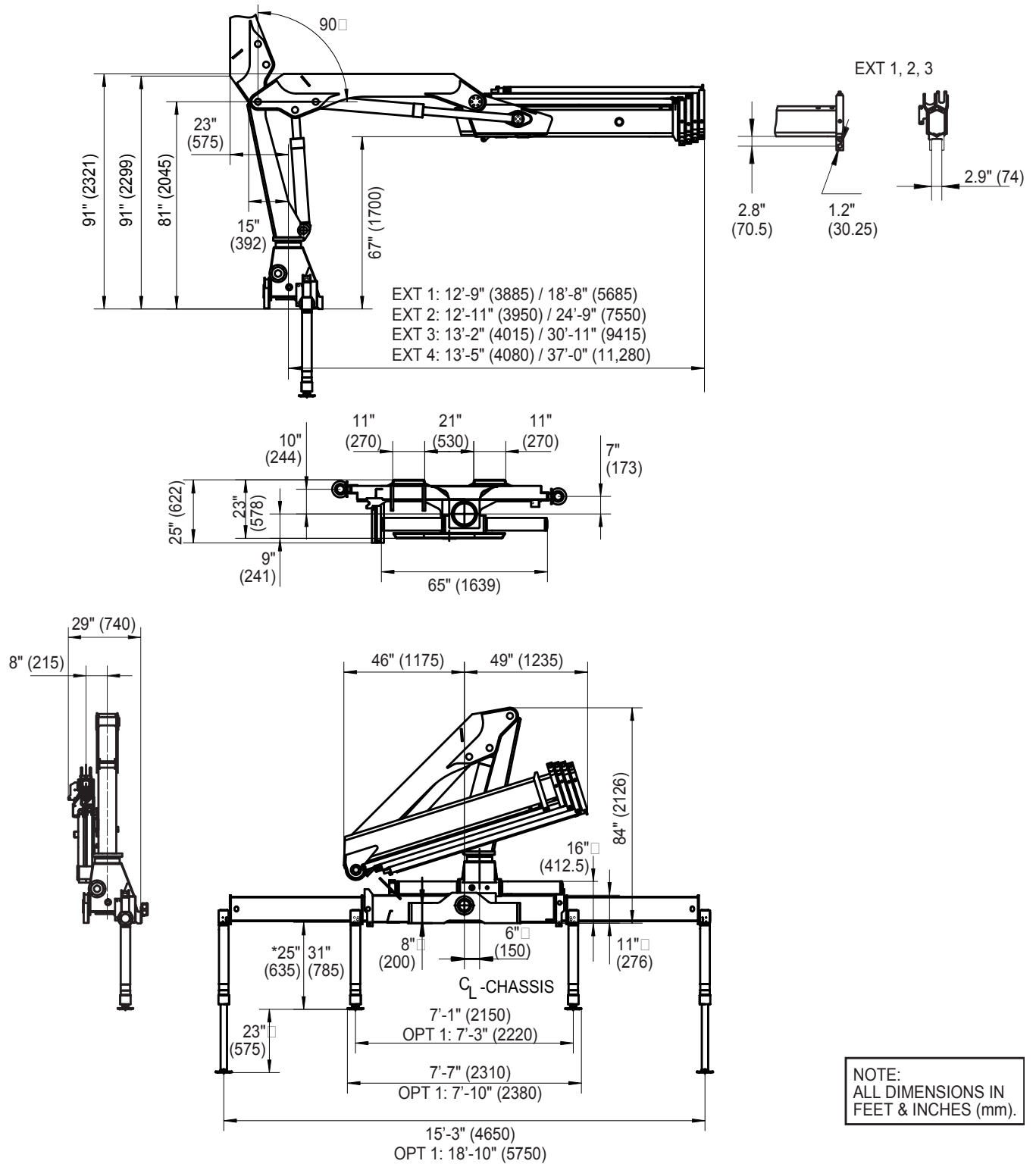

6.2 Specifications

PERFORMANCE	1-HYDRAULIC	2-HYDRAULIC	3-HYDRAULIC	4-HYDRAULIC
CRANE RATING*	62,930 ft-lb (8.7 tm)	61,480 ft-lb (8.5 tm)	58,590 ft-lb (8.1 tm)	57,865 ft-lb (8.0 tm)
MAX. REACH (HORIZ.)	18'-8" (5.7 m)	24'-11" (7.6 m)	30'-10" (9.4 m)	37'-1" (11.3 m)
MAX. REACH (VERT)	25'-3" (7.7 m)	31'-2" (9.5 m)	36'-9" (11.2 m)	37'-1" (13 m)
MAX. CAPACITY	7165 lb (3250 kg)	6945 lb (3150 kg)	6770 lb (3070 kg)	6615 lb (3000 kg)
MAX. CAPACITY AT				
MAX. REACH	3570 lb (1620 kg)	2535 lb (1150 kg)	1865 lb (845 kg)	1410 lb (640 kg)
CRANE WEIGHT **	2315 lb (1050 kg)	2515 lb (1140 kg)	2710 lb (1230 kg)	2890 lb (1310 kg)
HOOK APPROACH				
VERTICAL	8'-10" (2.7 m)	8'-6" (2.6 m)	8'-3" (2.5 m)	7'-10" (2.4 m)
HORIZONTAL	3'-3" (1.0 m)	3'-3" (1.0 m)	3'-3" (1.0 m)	3'-3" (1.0 m)
CENTER OF GRAVITY				
VERTICAL	21.9" (555 mm)	22.0" (560 mm)	22.4" (570 mm)	22.8" (580 mm)
HORIZONTAL ***	0.4" (10 mm)	0.6" (15 mm)	1.0" (25 mm)	1.4" (35 mm)

*Crane rating (ft-lb) is the rated load (lb) times the respective distance (ft) from the centerline of rotation with all extensions retracted and the inner and outer booms in a horizontal position, per ANSI B30.22

**Crane weight does not include stabilizers.

***Centerline rotation to bridge.

SPECIFICATIONS

STABILIZER PAD DIAMETER	6.3" (160 mm)
CRANE STORAGE HEIGHT	7'-0" (2.1 m)
MOUNTING SPACE	27.0" (680 mm)
(Allow an additional 7" between the cab and the crane base for swing clearance.)	
ROTATIONAL TORQUE	10,050 ft-lb (1.4 tm)
ROTATION	400 degrees
OPTIMUM PUMP CAPACITY	9 gpm (35 L/min)
SYSTEM PRESSURE	4,565 psi (315 bar)
OIL RESERVOIR CAPACITY	11.1 gal (42 L)
STABILIZER EXTENSION SPAN	
STANDARD (Manual out, hydraulic down)	15'-3" (4.7 m)
WEIGHT	380 lb (173 kg)
OPTION 1 (Manual out, hydraulic down)	18'-10" (5.8 m)
WEIGHT	540 lb (245 kg)
(Option 1 recommended for rear mount applications.)	

MINIMUM CHASSIS SPECIFICATIONS

FRONT AXLE RATING (GAWR)	9,000 lb
REAR AXLE RATING (GAWR)	17,000 lb
RESISTANCE TO BENDING MOMENT (RBM)	960,000 in-lb

WORKING SPEEDS

ROTATIONAL SPEED	20 °/sec
------------------	----------

WEIGHTS

MOUNTING BOLTS	116 lb (53 kg)
OIL IN BASE AND CYLINDERS	88 lb (40 kg)
STANDARD TANK WITH OIL	123 lb (56 kg)
CRANE WEIGHT, EXCLUDING STABILIZERS	K1: 2314 lb (1050 kg) K2: 2513 lb (1140 kg) K3: 2711 lb (1230 kg) K4: 2888 lb (1310 kg)

POWER CONSUMPTION /PUMP PERFORMANCE

WORKING PRESSURE	4567 psi (31.5 MPa)
POWER CONSUMPTION	18 KW
OIL CAPACITY IN BASE	7.4 gal (28 l)
OIL CAPACITY IN SEPARATE TANK	11.1 gal (42 l)

7.0 Working Pressure / Performance

The working pressure should be set with a pressure gauge. Keep the pressure below the limits as shown in the following tables. Check the working pressure at least annually, and during any major repair, following the procedure described in the IMT Crane Log manual. All adjustable valves must be resealed after pressure setting adjustment.

WORKING PRESSURE-9-63

FIGURE 10: WORKING PRESSURE VALVE TEST/ADJUSTMENT POSITION

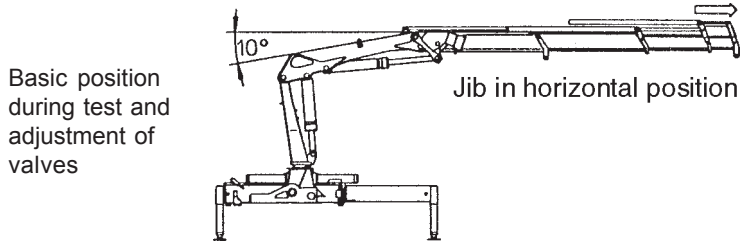

Working pressure on main-relief valve & port-relief valves

Function		Port	02	03	04
Main-relief valve				4568 psi (31.5 MPa)	
Stabilizer legs/ grab, rotator	up	A-port		2175 psi (15.0 MPa)	
	down	B-port		2175 psi (15.0 MPa)	
		A-port		2175 psi (15.0 MPa)	
		A-port		2175 psi (15.0 MPa)	
Inner boom cylinder	down	A-port		1813 psi (12.5 MPa)	
	up	B-port		4713 psi (32.5 MPa)	
Outer boom cylinder	up	A-port		3988 psi (27.5 MPa)	
	down	B-port		2538 psi (17.5 MPa)	
Extension cylinders	extend	A-port		P	
	retract	B-port		P	
Rotation system	right	A-port		2175 psi (15.0 MPa)	
	left	B-port		2175 psi (15.0 MPa)	
Separate stabilizer valve				2175 psi (15.0 MPa)	

Opening pressure on load holding valves

Inner boom cylinder				4931 psi (34.0 MPa)
Outer boom cylinder				3988 psi (27.5 MPa)
Extension cyl C1-V1	retract	B-port		6236 psi (43.0 MPa)
Extension cyl C2-V2	extend	A-port		3045 psi (21.0 MPa)
External relief valve				

Pressure setting for load moment limitation

LMB				4423 psi (30.5 MPa)
-----	--	--	--	---------------------

Max. Pump performance

Pump performance K2				9.25 gpm (35 l/min)
Pump performance K3-K4				7.93 gpm (30 l/min)

8.0 Hydraulic System

8.1 Description

The loader valve block is a “stack” type, consisting of a number of separate control valves. A main relief valve is fitted in the inlet section of the valve block to ensure that the oil pressure in the pump line does not exceed the permissible limit. This valve is adjustable and must always remain sealed.

Port relief valves are mounted at the ports of the individual control valves to limit the pressure in the individual circuits. The port relief valves are pre-set and not adjustable.

The inner, outer, and extension cylinders are mounted with load holding valves with the following functions:

1. Protect cylinders against excessive pressure.
2. Speed control when the boom is lowered.
3. To maintain the boom in position during operations where a fixed boom position is required.
4. Lock the boom and maintain the load in position in case of hose or pipe rupture.

The stabilizer cylinders are equipped with a piloted check valve that locks the cylinder in case of damage to the hydraulic system.

CAUTION

The main relief valve, the load holding valves, the dump valve and the external relief valve are sealed. Check these seals regularly and have an authorized IMT service center replace them if damaged.

8.2 Recommended Hydraulic Oil Types

Oil Brand	Oil Type	Low Temp Oil Type
BP	Bartran HV 32	Bartran HV 22
Castrol	Hyspin AWS 32	Hyspin AWH 32
ESSO	Nuto H 32	Univis N 22
Mobil	DTE 13	DTE 11
Shell	Tellus S 32	Tellus T 32
Statoil	Hydra Way HM 32	Hydra Way HV 22
Texaco	Rando HD 32	Rando HDZ 32

8.3 Hydraulic Diagrams

The following page contains the hydraulic diagram for the loader in standard application. There may be changes in design of the hydraulic system when applied to special and/or customized loaders. In these cases refer to the supplementary documentation.

STANDARD HYDRAULIC DIAGRAM

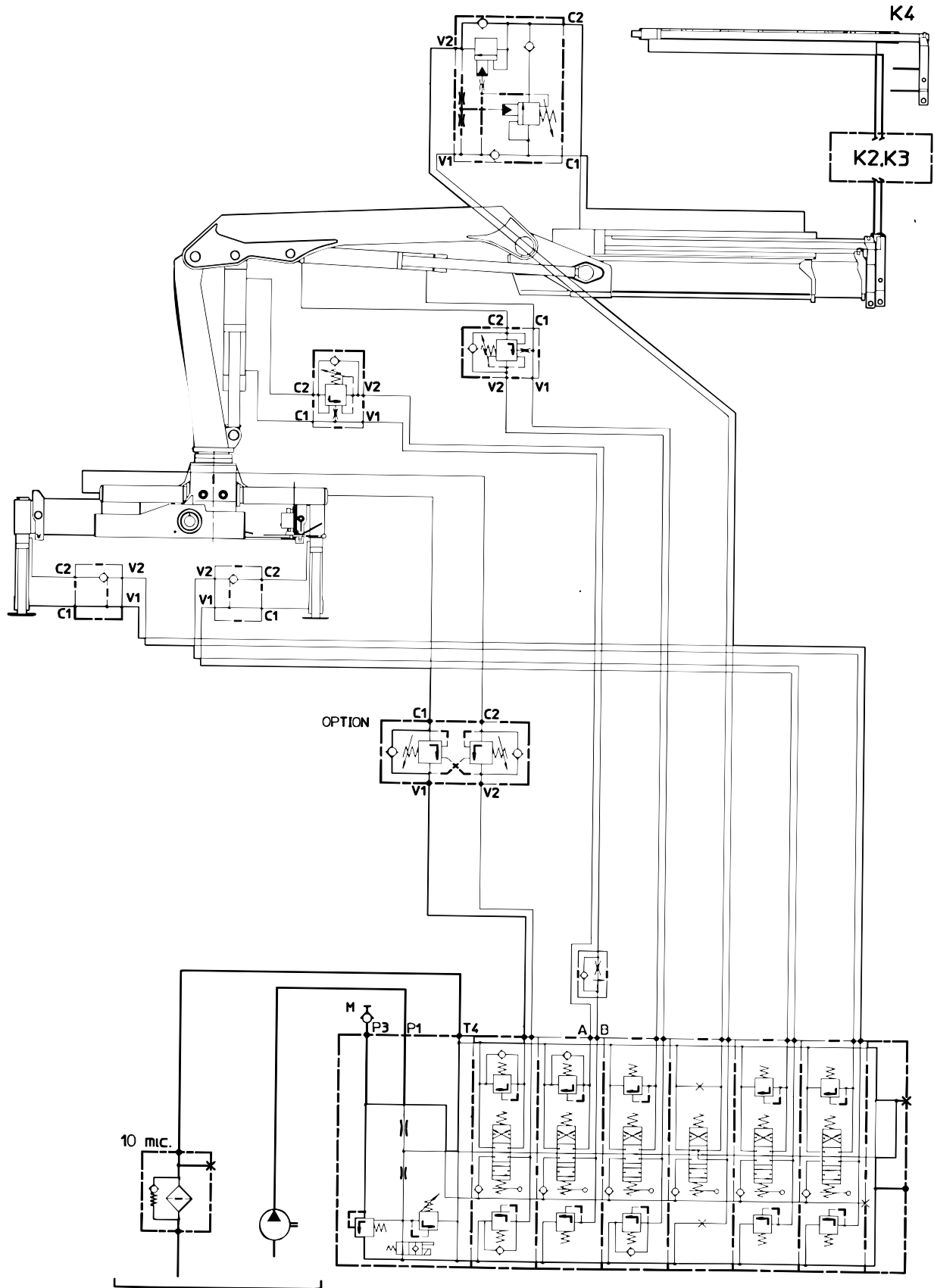

9.0 Bleeding of Cylinders

If air has entered the hydraulic system, bleed the air from the loader.

1. Raise and lower each stabilizer leg twice.
2. Extend and retract the inner boom cylinder twice.
3. Extend and retract the outer cylinder twice with the inner boom pointing downward, and twice with the inner boom pointed upward.
4. Extend and retract the extension cylinder twice with the outer boom pointed almost vertically upward, and twice with the outer boom pointed almost vertically downward.

10.0 Repair

If defects, damage or leaks are found, repair them immediately. Always have your repairs performed by an authorized IMT service center. Repairs to the hydraulic system must be made only at an authorized service center.

When ordering parts for your loader, please state:

- Loader model (9/63)
- Loader serial number (found on serial number placard on loader)

11.0 Service

11.1 Initial Service Overhaul

The initial service overhaul is recommended after the first 20 hours of service or after one month of loader use, whichever comes first.

The service overhaul should include:

1. Change of return filter element and high pressure filter cartridge, if applicable.
2. The oil level in tank and rotation system. Oil must be visible between maximum and minimum lubrication on the oil level rod, when the loader is in the folded position. The oil level in the slewing system should also be visible in the inspection tube.
3. Overall lubrication according to the lubrication chart in this manual.
4. Leak check and tightening of fittings, if required.
5. Checking of working pressure and lead seals. The correct working pressures are stated in Section 7.0.
6. Test all functions under load.
7. Checking and, if required, tightening of mounting bolts and pin connections.
8. Checking of all lock bolts and pins.

11.2 Annual Service Overhaul

Each year the loader should be given a complete service overhaul at an authorized IMT service center. The service check must include:

1. Oil change for hydraulic oil in tank and rotation system.
2. Filter change for return filter element and high pressure filter cartridge.
3. Air filter cleaning or replacement.
4. Working pressure and valve lead seal check.
5. Idling pressure check.
6. Complete function test under load.
7. Check slide blocks and bearing bushings for wear. Replace if necessary.
8. Check hydraulic hoses.
9. Leak check and tighten all connections.
10. Check pump and transmission.
11. Check loader base to chassis mounting hardware.
12. Check all bolt connections. Tighten if required.
13. Check overall loader structure for damage. Any damage found should be repaired immediately.
14. Check bolts and lock plates.

12. Load Moment Limitation

The loader is equipped with a load moment limitation system (LMB). This system ensures that the permissible load moment is never exceeded, irrespective of the operator's doings.

However, it is important to keep in mind that the LMB-system does not necessarily ensure sufficient vehicle stability. Before starting to work with the loader, the operator must always make sure that the vehicle is stable in the entire slewing area of the loader. However, if the loader is equipped with an EVS-system (Electronic Vehicle Stability), the stability of the vehicle is ensured in the entire working area, because the system is constantly checking the vehicle, and immediately stopping the load moment increasing movement in case of instability, irrespective of the operator's doings.

Note

The RCL system is described in detail in the Instruction Manual - RCL Safety System. The loader operator should be familiar with the RCL system.

13. Heavy Duty Lifting - HDL

If the loader is equipped with a Heavy Duty Lifting (HDL) system, the loader can attain an increased lifting capacity at reduced speed.

When the loader reaches its normal lifting capacity limit, the HDL-system will automatically be activated and the oil flow to the control valve will be reduced to approximately 20 percent of the normal oil flow. At the same time, the loader lifting capacity is increased by approximately 10 percent in the entire working area of the loader. When the HDL-system is activated, the operator will be able to continue extending the load without interruption, although at reduced speed.

If the load moment is reduced to permitted load limits again, the HDL-system will increase the oil flow to normal and the working speed will increase again. However, the automatic disconnection implies that all control levers have been into neutral position at the same time as the load moment has been reduced to the permitted load limit.

Please also see chapter on "Heavy Duty Lifting, HDL" in the manual: Instruction Manual - RCL Safety System.

14. Hoses and Hydraulic Pipes

The hoses must comply with the SAE R100 2AT standard.

The pipes are manufactured in St.35.4C-NBK.

IOWA MOLD TOOLING CO., INC.

BOX 189, GARNER, IA 50438-0189

TEL: 641-923-3711

TECHNICAL SUPPORT FAX: 641-923-2424