



Model 6/45

Instruction Manual



NOTE

Read and understand this manual, the
IMT Operators Crane Safety Manual
and Safety Manual Supplement
before operating or maintaining your crane.

IOWA MOLD TOOLING CO., INC.

BOX 189, GARNER, IA 50438-0189

TEL: 641-923-3711

TECHNICAL SUPPORT FAX: 641-923-2424

Iowa Mold Tooling Co., Inc. is an Oshkosh Corporation company.

TABLE OF CONTENTS

TABLE OF CONTENTS	2	4.0 Maintenance	12
REVISIONS LIST	2	4.1 Maintenance of the Loader	12
1.0 Loader Terminology	3	4.2 Lubrication intervals	13
2.0 Operating Instructions	3	4.3 Lubrication Chart	13
2.1 Starting Up	3	4.4 Recommended Hydraulic Oil Types	14
2.2 Operating the Stabilizer Legs	4	4.5 Recommended Lubrication Grease	14
2.3 Folding / Unfolding the Loader	4	4.6 Filter	14
2.4 Attaching the Load	4	4.7 Cold Weather Start-up	14
2.5 Loader Reach	4	4.8 Bleeding of Cylinders	15
2.6 Capacity Charts	5	4.9 Change of Rotation Area	16
6/45K1	5	5.0 Loader Designation	17
6/45K2	6	6.0 Accessories	17
6/45K3	7	6.1 Manual Extensions	17
6/45K4	8	7.0 Technical Data	18
2.7 Operating the Loader	9	7.1 Dimensional Drawing	18
3.0 The Hydraulic System	10	7.2a Technical Data (Domestic)	19
3.1 Hydraulic Diagram, Standard	10	7.2b Technical Data (Metric)	20
3.2 Hydraulic Diagram, with Extra Valves	11	7.3a Working pressure-6/45 (domestic)	21
3.3 Description of the Hydraulic System	12	7.3b Working pressure-6/45 (metric)	21
		8.0 Repair	21

REVISIONS LIST

DATE	LOCATION	DESCRIPTION OF CHANGE
20001130	PG 5-8 PG 19-20	UPDATED CAPACITY CHARTS 6/45K1-4 (MODEL CHG ONLY VS. 1H-4H) UPDATED SPECS/TECH DATA (DOMESTIC & METRIC)
20061113	PG. 1	UPDATED OWNERSHIP STATEMENT
20070510	PG 5-8	ECN 9000 - UPDATED CAPACITY CHARTS FOR CONSISTENCY ACROSS MODELS
20071112	PG. 5-8, 18-20	ECN 9000- ADDITIONAL CAPACITY CHART UPDATES; CONSISTENCY ON DRAWING, TECH DATA
20111201		ECN 11628 - UPDATE STABILIZER WORDING, ELECTROCUTION DISTANCES

1.0 Loader Terminology

The loader is designed as a truck mounted loader and therefore stationary mounting of the loader, mounting on agricultural tractors, special purpose vehicles and the like may only be performed according to specific agreement with IMT.

1. Suspension traverse
2. Control valve block
3. Stabilizer beam
4. Stabilizer leg
5. Rotation/Slewing cylinder
6. Base
7. Inner/Boom cylinder
8. Mast/Column
9. Hinge pin
10. Inner/Main boom
11. Outer/Jib cylinder
12. Outer/Jib pin
13. Outer boom/Jib
14. Extension boom
15. Extension cylinder

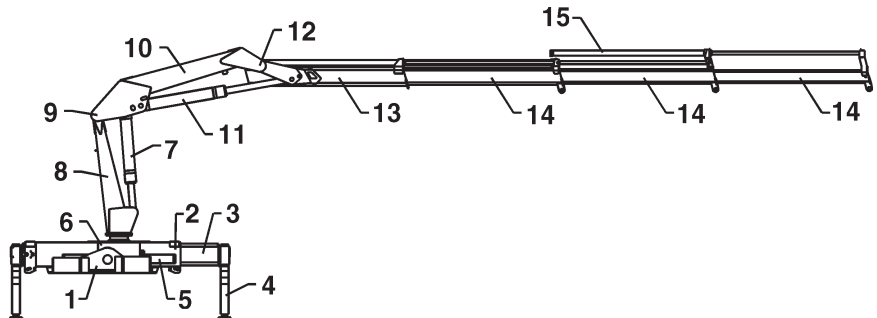

2.0 Operating Instructions

2.1 Starting Up

Before operating the loader:

- Set the vehicle's parking brake.
- Check the oil level in the tank.
- Ensure that the hydraulic hoses are not damaged, twisted, or jammed.
- Check all hooks, slings, safety latches and chains.
- The manual extensions must be correctly fastened with the lock bolts and split pins.
- If the hydraulic system works with tipping body or other hydraulic equipment, check that the change-over (selector) valve is switched to the "loader" position. This valve must not be operated while the pump is functioning. Then start the engine, disengage the clutch and engage the power take-off by pulling the handle in the driver's cab.

Safe Distance to Electric Wires

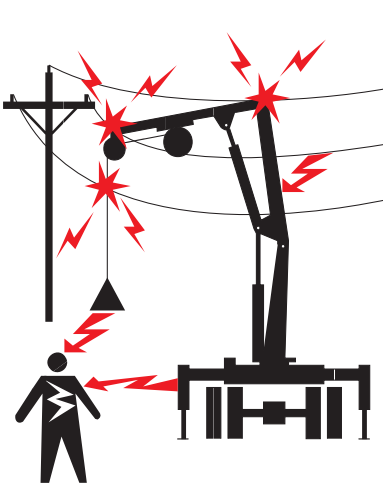
 DANGER	
<p>Electrocution Hazard</p> <p>Crane is not insulated</p> <p>NEVER approach or contact power lines with any part of this equipment or load.</p> <p>Keep 50 feet away from any power line if voltage is not known.</p> <p>Keep 20 feet away from any power line 350 kilovolts or less.</p> <p>Account for swaying motion of power line, equipment, and load line.</p> <p>Follow OSHA 29CFR 1926.1400.</p> <p>Death or serious injury will result from approaching or contacting a power line.</p>	
<small>70392813</small>	

2.2 Operating the Stabilizer Legs

The stabilizer beams must be fully extended. The stabilizer legs are lowered just enough to raise the truck chassis a little in its suspension. The truck and loader should be placed on as even surface as possible to ensure a perfect rotation movement of the loader.

If the truck is parked on uneven ground, it can be levelled by means of the stabilizer legs, which may be operated individually.

If the loader is to work on soft ground it may be necessary to place blocks or steel plates under the stabilizer legs to ensure sufficient stability.

When the work has been completed, raise the stabilizer legs and push the beams back into place. Check that the swivel lock is engaged.

2.3 Folding / Unfolding the Loader

WARNING

Fully deploy the stabilizers before operating the loader. Failure to do so can result in equipment damage, personal injury or death.

When the stabilizer legs have been lowered, the boom is unfolded as shown below:

Unfolding

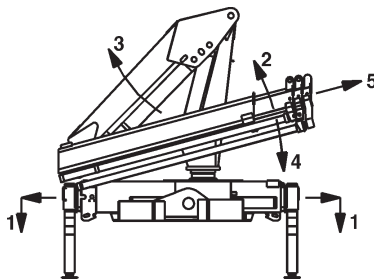

Folding

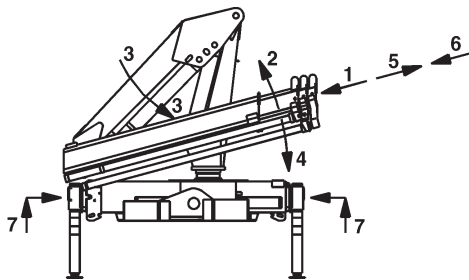

Never begin the unfolding process by activating the rotation system.

2.4 Attaching the Load

The load and auxiliary equipment must be attached securely and carefully to the hook either directly or by means of straps or chains.

2.5 Loader Reach

Figures for reach and lifting capacity are shown in the following diagrams.

Please note that the lifting capacities stated are valid when the main boom is approx. 15° above horizontal.

2.6 Capacity Charts

6/45K1

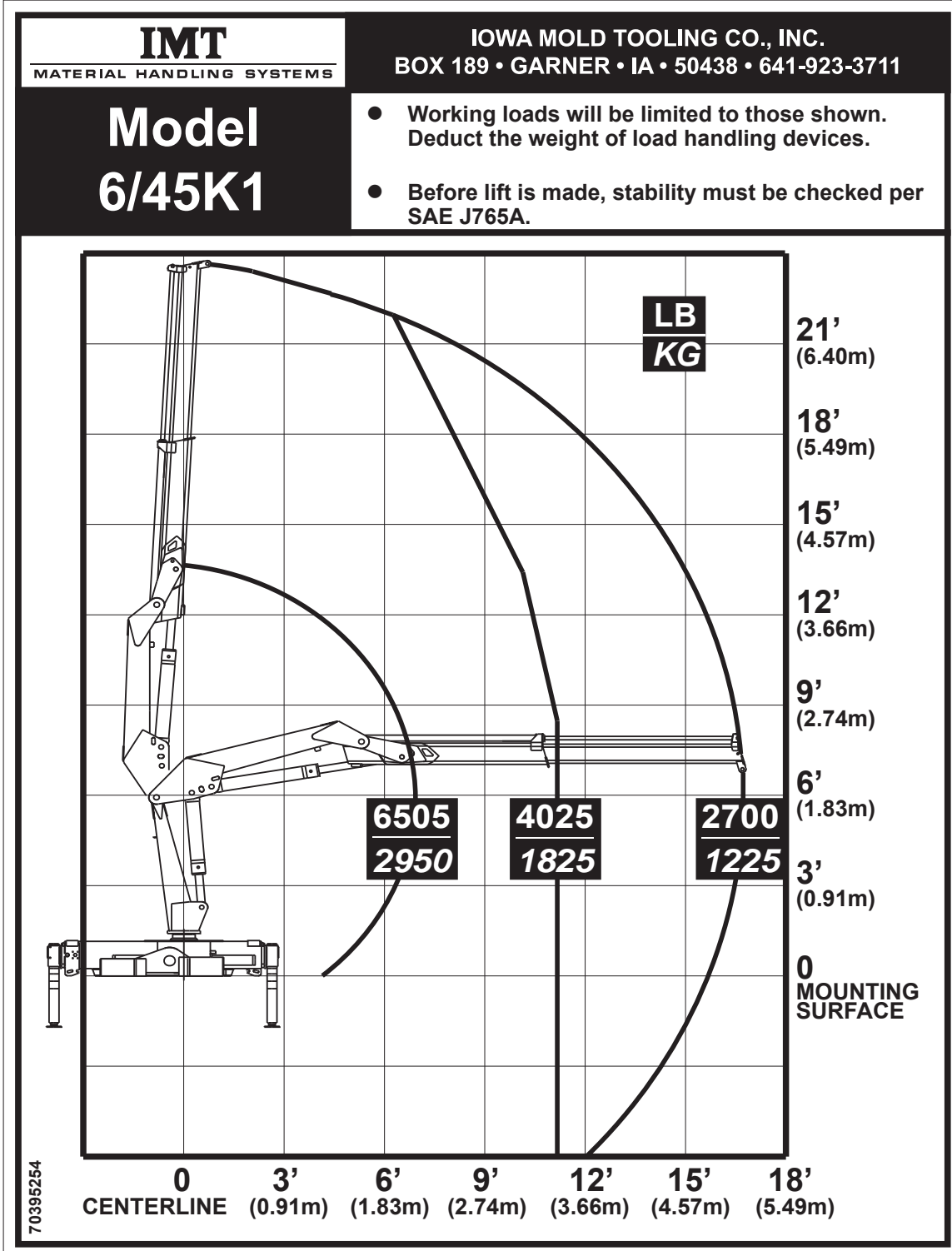

6/45K2

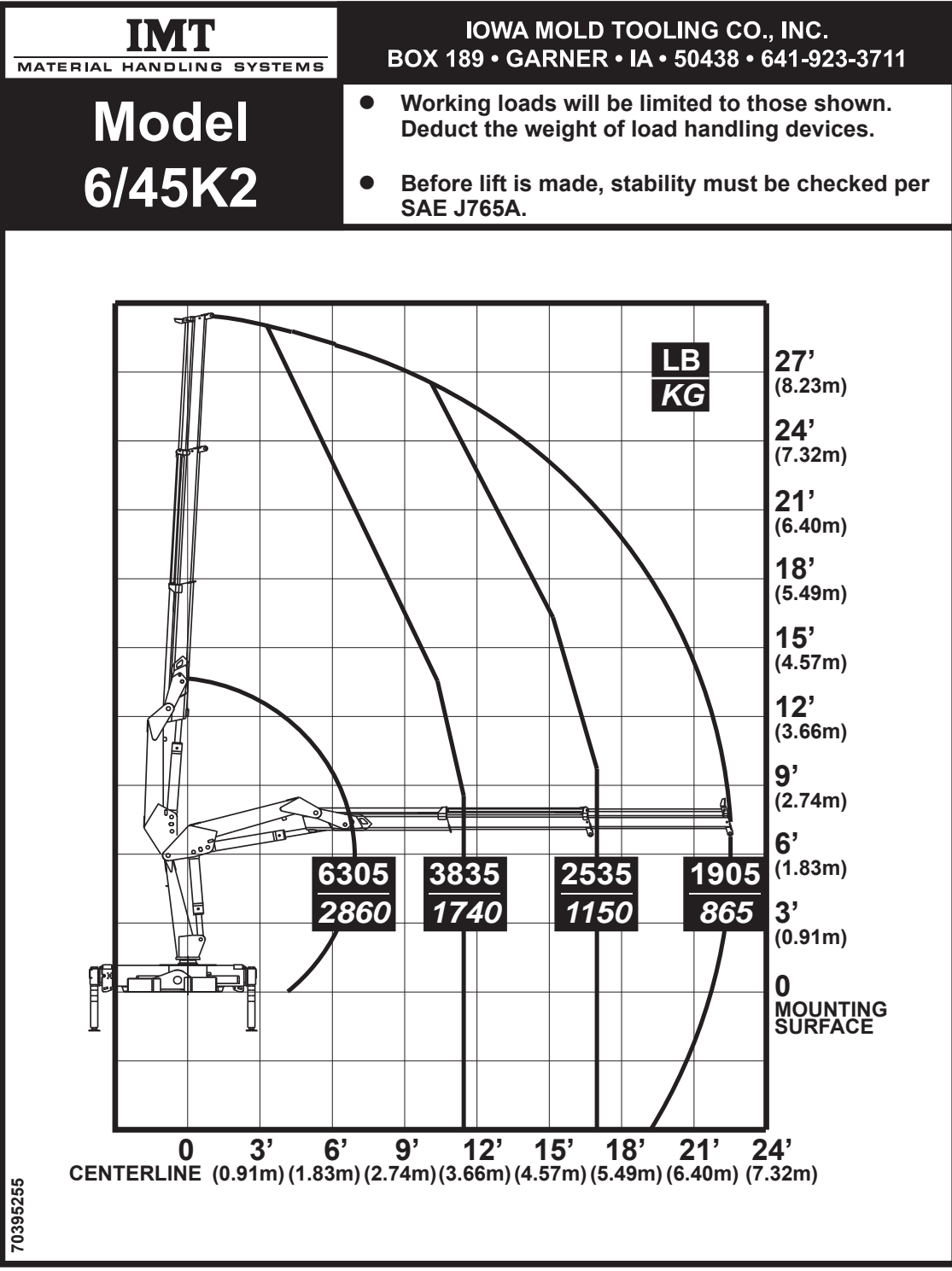

6/45K3

 IMT MATERIAL HANDLING SYSTEMS	IOWA MOLD TOOLING CO., INC. BOX 189 □ GARNER □ IA □ 50438 □ 641-923-3711
<h1>Model 6/45K3</h1>	<ul style="list-style-type: none"> Working loads will be limited to those shown. Deduct the weight of load handling devices. Before lift is made, stability must be checked per SAE J765A.

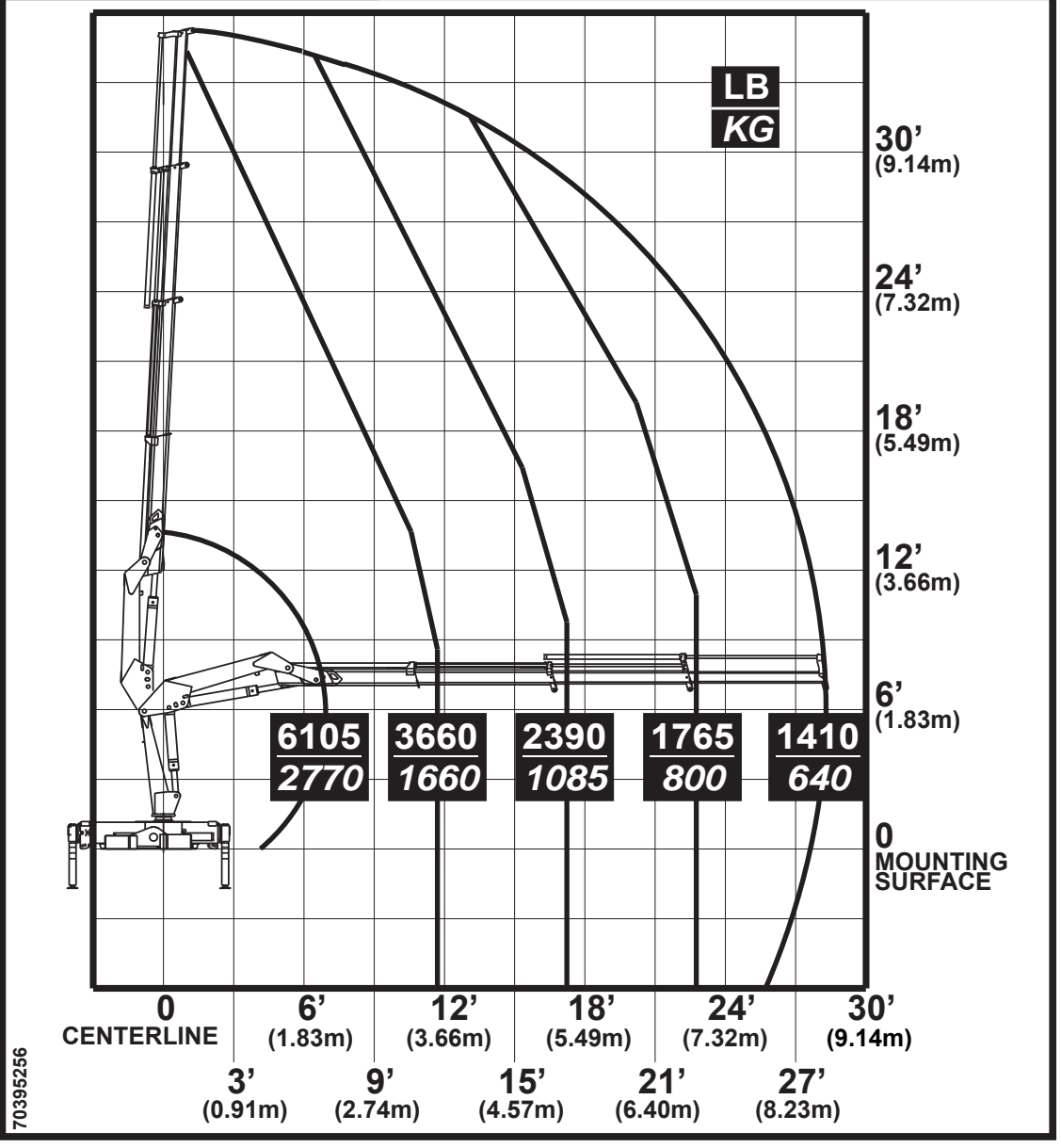

6/45K4

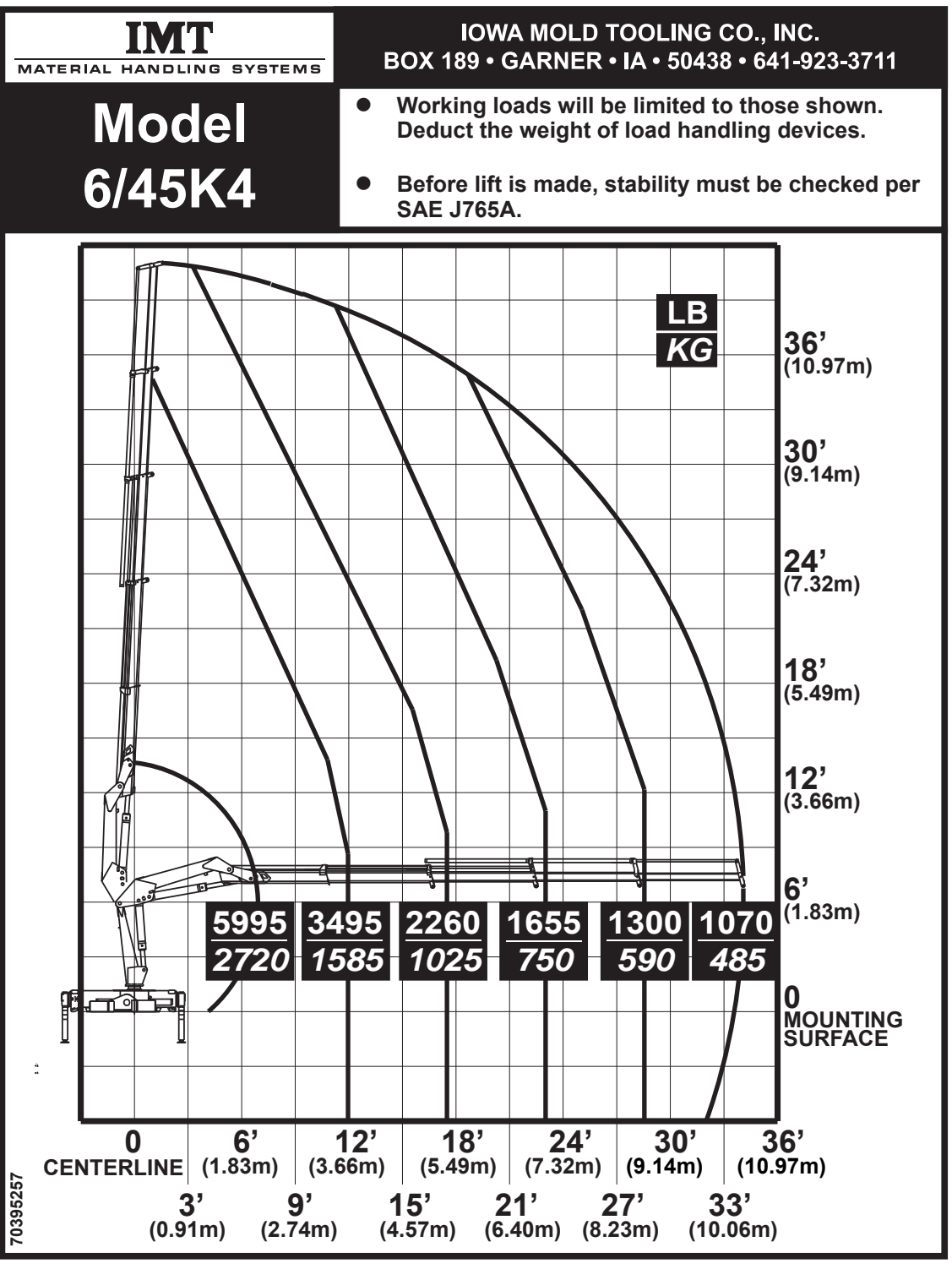

2.7 Operating the Loader

The control valves should be operated gently - especially when handling heavy loads. The working speed of the loader can be regulated by careful operation of the control valves. Jerky operation of the control levers causes the load to swing and move uncontrollably and will put unnecessary strain on the loader.

Whenever possible, the loader should be operated (by means of dual control) from the opposite side from where the load is suspended, in order to avoid personal injuries in case of accident.

NOTE:

Maximum lifting capacity is attained by raising the main boom 10-15° above horizontal .

CONTROL PANEL Standard Loader

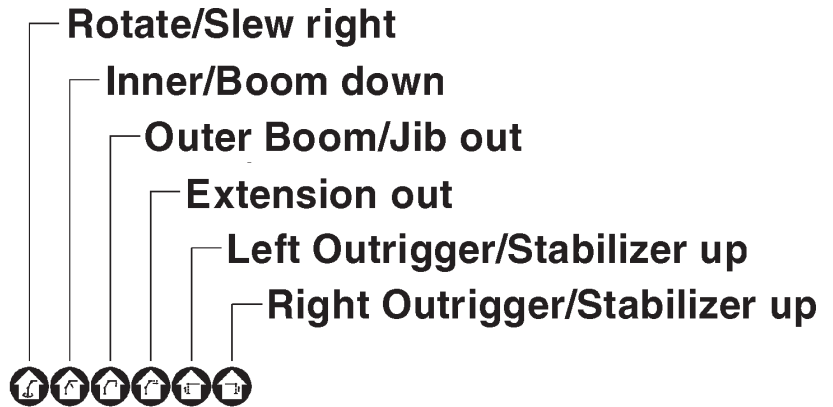

CONTROL PANEL Loader with Extra Valves

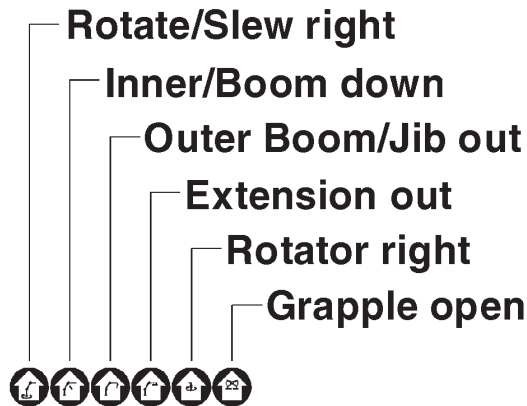

-  – Right Outrigger/Stabilizer up
-  – Left Outrigger/Stabilizer up

3.0 The Hydraulic System

3.1 Hydraulic Diagram, Standard

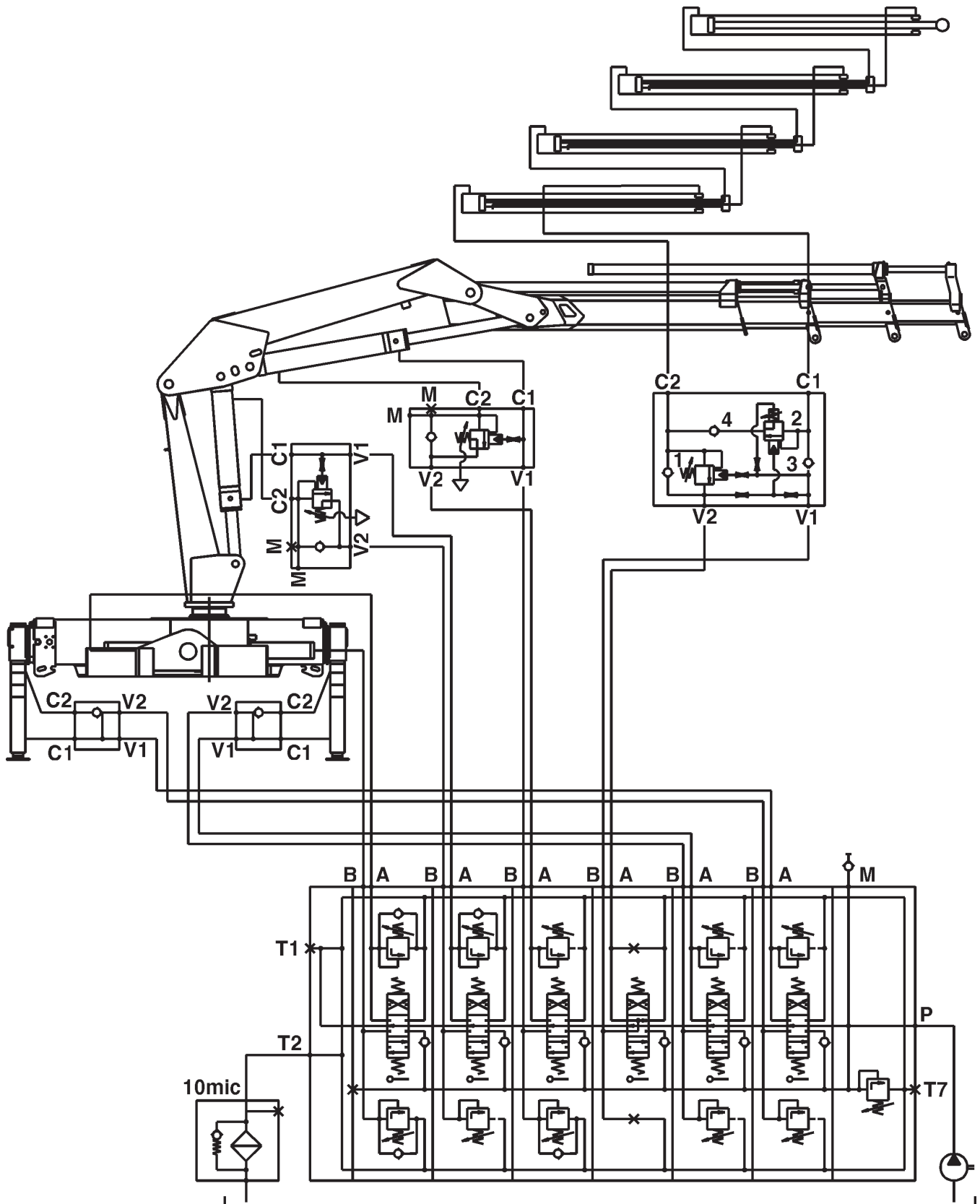

3.2 Hydraulic Diagram, with Extra Valves

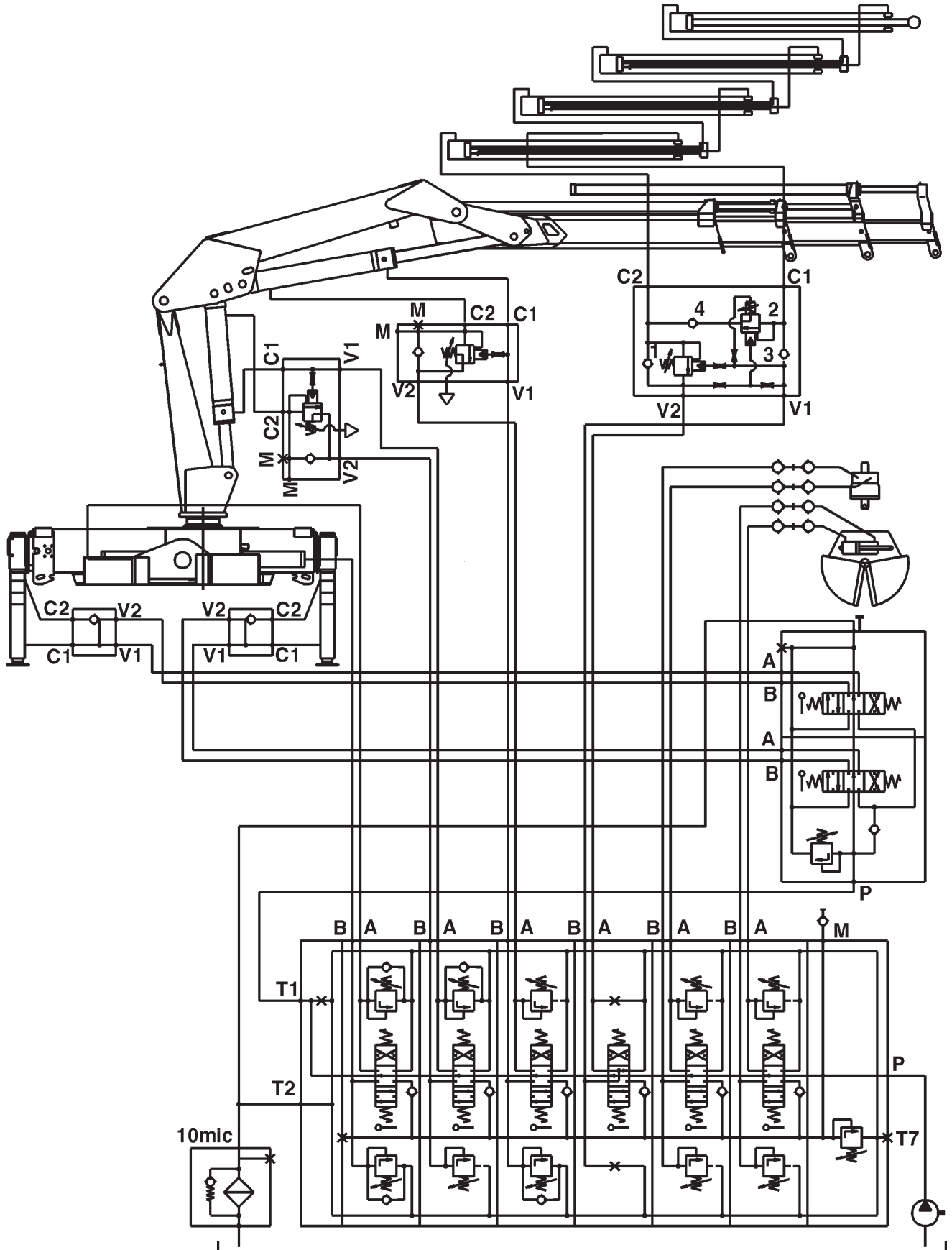

3.3 Description of the Hydraulic System

The valve block of the loader is of the stack type which is made up of a number of separate control valves. This ensures great flexibility and low maintenance costs.

A main relief valve is fitted in the inlet section of the valve block to ensure that the oil pressure in the pump line does not exceed the permissible limit. This valve is adjustable and must always remain sealed.

Port relief valves are mounted at the ports of the individual control valves to limit the pressure in the individual circuits. Normally the port relief valves will be preset and not adjustable.

The inner, outer and extension cylinders are mounted with load holding valves with the following functions:

1. Protection of cylinders against excessive pressure.
2. Checking of the lowering speed of the boom.
3. Maintain the boom in position during operations where a fixed boom position is required.
4. To lock the boom and maintain the load in position in case of hose or pipe rupture.

The stabilizer legs are equipped with a piloted check valve that locks the cylinder in case of damage to the hydraulic system.

Important:

The main relief valve and the load holding valve on the boom cylinder are sealed. If these seals are broken or removed, the warranty will automatically be invalidated. Therefore, it is in your own interest to have the lead seals checked periodically, and to ensure that they are replaced by an authorized IMT service center should they be damaged.

Any modification or alteration to the hydraulic system must be in accordance to specific agreement with IMT and such alterations should always take place at an IMT service center.

4.0 Maintenance

4.1 Maintenance of the Loader

Careful maintenance of the loader is the best way to ensure reliable loader operation.

At regular intervals, every day or every week, depending on frequency of loader application, the following should be checked:

1. The oil level in tank/rotation system. Oil must be visible between maximum and minimum indication on the oil level glass.
2. Any defects, damage or leaks should be repaired at an authorized IMT service center as soon as they are discovered.
3. That mounting of loader to truck is safe.
4. Slide blocks and bushings reduce friction and therefore are subject to wear. Slide blocks should be replaced if excessive free play is found in the boom system. Bushings should be replaced before the metal components physically touch each other.
5. All hoses for defects.
6. That hooks, straps, latches, etc. are in good working order.
7. All lock pins and bolts for wear and tear.

In case of any warranty claims, great importance will be attached to observance of the annual service overhauls.

4.2 Lubrication intervals

Base bearings	after 20 hours of operation / 1 week (whatever occurs first)
Extension system/ Slide blocks	after 50 hours of operation / 1 month (whatever occurs first)
Pin connections/ bolts	after 50 hours of operation / 1 month (whatever occurs first)
Stabilizer beams	as required
Control valves and rod connections (oil spray)	as required

The loader should be lubricated according to the lubrication chart below.

4.3 Lubrication Chart

The rotation system should be activated, then rotate the loader from stop to stop several times within the entire rotation area while lubricating bearings in the base.

Hydraulic oil and lubrication grease are chosen according to the table in section 4.4: "Recommended Hydraulic Oil Types" and section 4.5: "Recommended Lubrication Grease".

The telescopic extensions are lubricated with a special grease, ESSO ESL 454 or LE Pyroshield 5182.

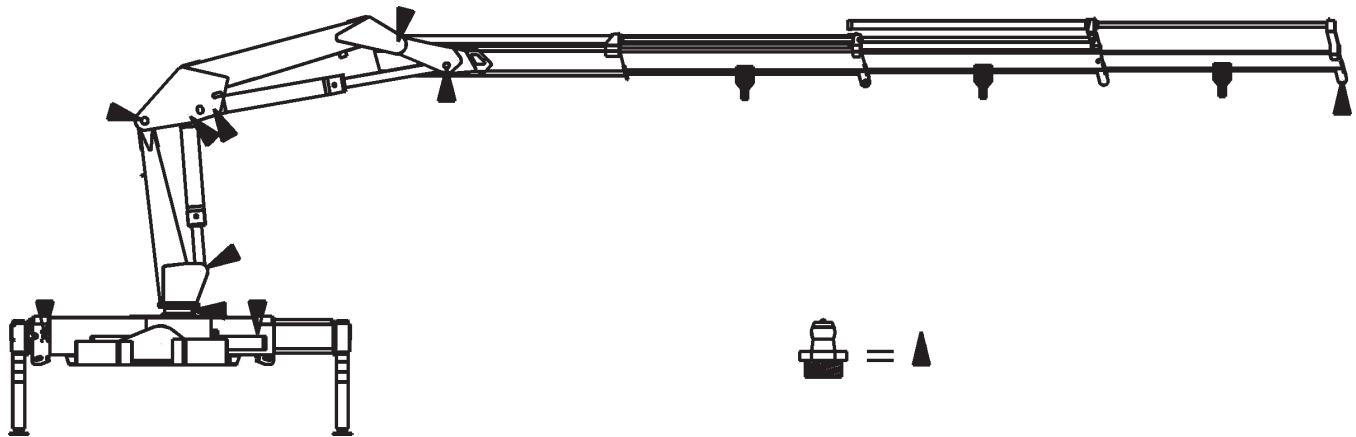

4.4 Recommended Hydraulic Oil Types

The hydraulic oil should be chosen according to the table below. If the loader is to work at temperatures below 32°F (0°C) for an extended period of time, an oil type suited to exceptionally low temperatures should be used, since it has a higher viscosity index.

Other oil types may be used provided their quality and specifications correspond to those shown.

Oil Brand	Oil Type	Low Temp Oil Type
BP	Bartran HV 32	Bartran HV 22
Castrol	Hyspin AWS 32	Hyspin AWH 32
ESSO	Nuto H 32	Univis N 22
Kuwait petroleum Q8	Harmony 32 AW	Hydraulic L 32
Mobil	DTE 13	DTE 11
Shell	Tellus S 32	Tellus T 32
Statoil	Hydra Way HM 32	Hydra Way HV 32
Texaco	Rando HD 32	Rando HDZ 32

The order is alphabetical and implies no indication of quality.

In winter, 1% isopropyl alcohol may be added to the oil to avoid problems with condensation.

When operating during extreme temperatures (-40°F to +170°F / -40°C to +75°C) we recommend a hydraulic oil such as Esso Univis J26 or other brand of corresponding characteristics.

4.5 Recommended Lubrication Grease

Grease Brand	Grease for Bearings
BP	Energrease L52
Castrol	LM Grease
ESSO	MP Grease / Beacon EP 2
Mobil	Mobilux EP 2 or Mobilgrease HP
Shell	Retinox MS
Statoil	UniWay EP 2
Texaco	Multifak All Purpose EP 2

The order is alphabetical and implies no indication of quality.

Telescopic booms should be greased with special grease Esso ESL 454, to be applied where the telescopic booms contact the slide blocks.

4.6 Filter

The return filter must be replaced after 20 hours. Then replace the filter when performing an oil change - at least once a year.

CAUTION

Absolute cleanliness is essential when filling up the oil tank, changing oil, cleaning filters, and in all other work involving the hydraulic system.

4.7 Cold Weather Start-up

When you start up your loader in cold weather, the hydraulic system, especially the pump, is exposed to more wear than at normal temperatures. In order to minimize the wear, you should follow the two general rules set out below:

1. Engage the power take-off at low engine revolutions.
2. Let the pump circulate the oil for a few minutes before operating the loader.

4.8 Bleeding of Cylinders

If, for some reason, air has entered into the hydraulic system, the loader is bled as follows:

1. Fold the loader completely and fill the oil tank - it contains approx. 9.25 gallons (35 litres).
2. Bleeding procedure:

Remember to refill the oil tank after bleeding.

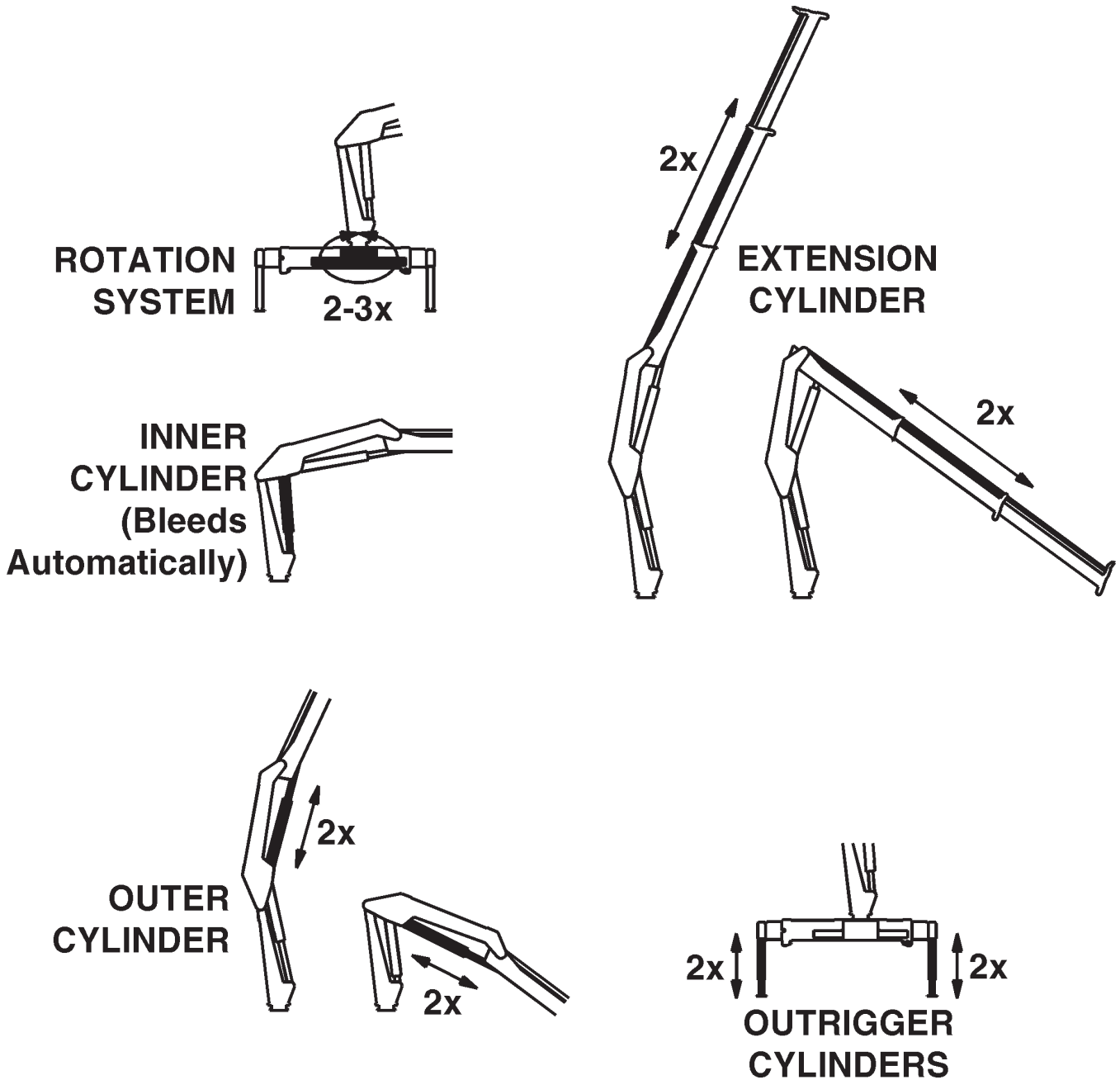

4.9 Change of Rotation Area

- a. Position the loader so that the rotation movement to both sides is exactly the same (neutral position).
- b. Empty the base of oil through the drain plug (5).
- c. Remove two rotation cylinders (1) on the same side.
- d. Note the distance "X". It must be the same for both racks (3). If this is not the case, the loader is not in neutral position. Check this distance again.
- e. Pull out the slide blocks (4) using the threaded hole (M12).
- f. Pull out the racks completely (3).
- g. Turn the loader mast manually to the required "C" position (Fig. II).
- h. Position the racks (3) according to item d. If the king pin and the racks do not mesh, the king pin/mast should be turned until the mesh.
- i. Place the slide blocks (4) behind the racks (3) and remount the rotation cylinders (1).
- j. Lubricate the bolts (2) with Locktite Normal or Locktite No. 242 and then remount them.
- k. Remount the drain plug (5), then add oil at the filler plug (6).

Fig. I

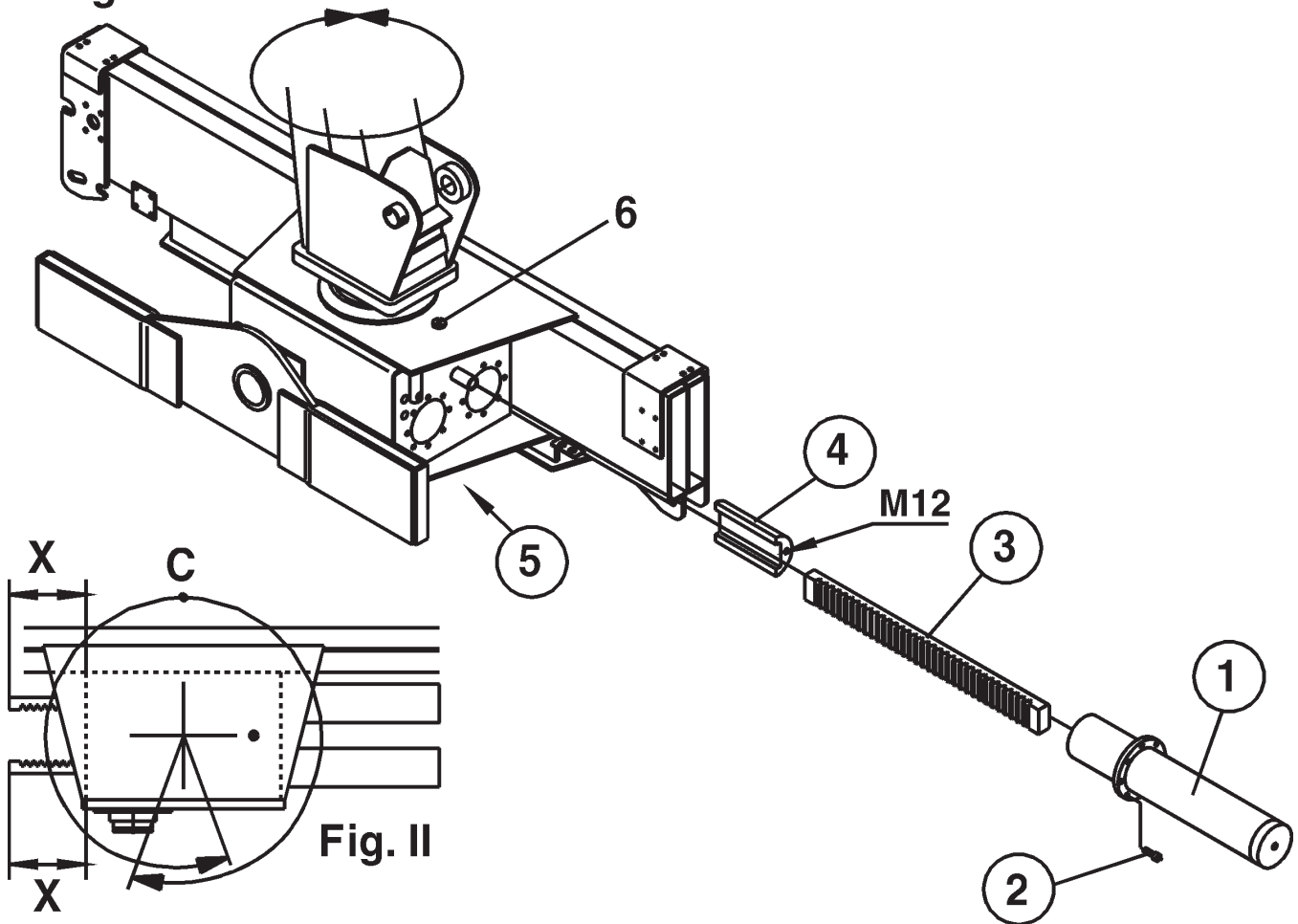

5.0 Loader Designation

Different loader applications apply different types of stress to the loader structure, and consequently the loaders are divided into loading groups according to application.

As standard the 6/45 (3H) loader designation describes a loader with a 6 ton-meter/45000 foot-pound load moment and utilizing 3 hydraulic extensions.

If the loader is stationary, the load moment of the loader is reduced.

6.0 Accessories

6.1 Manual Extensions

Information not available at time of printing.

NOTE

The load capacity limits indicated above for the hydraulic extensions will be reduced if the loader is mounted with manual extensions. This reduction in loader lifting capacity will correspond to the weight of the manual extensions mounted.

7.0 Technical Data

7.1 Dimensional Drawing

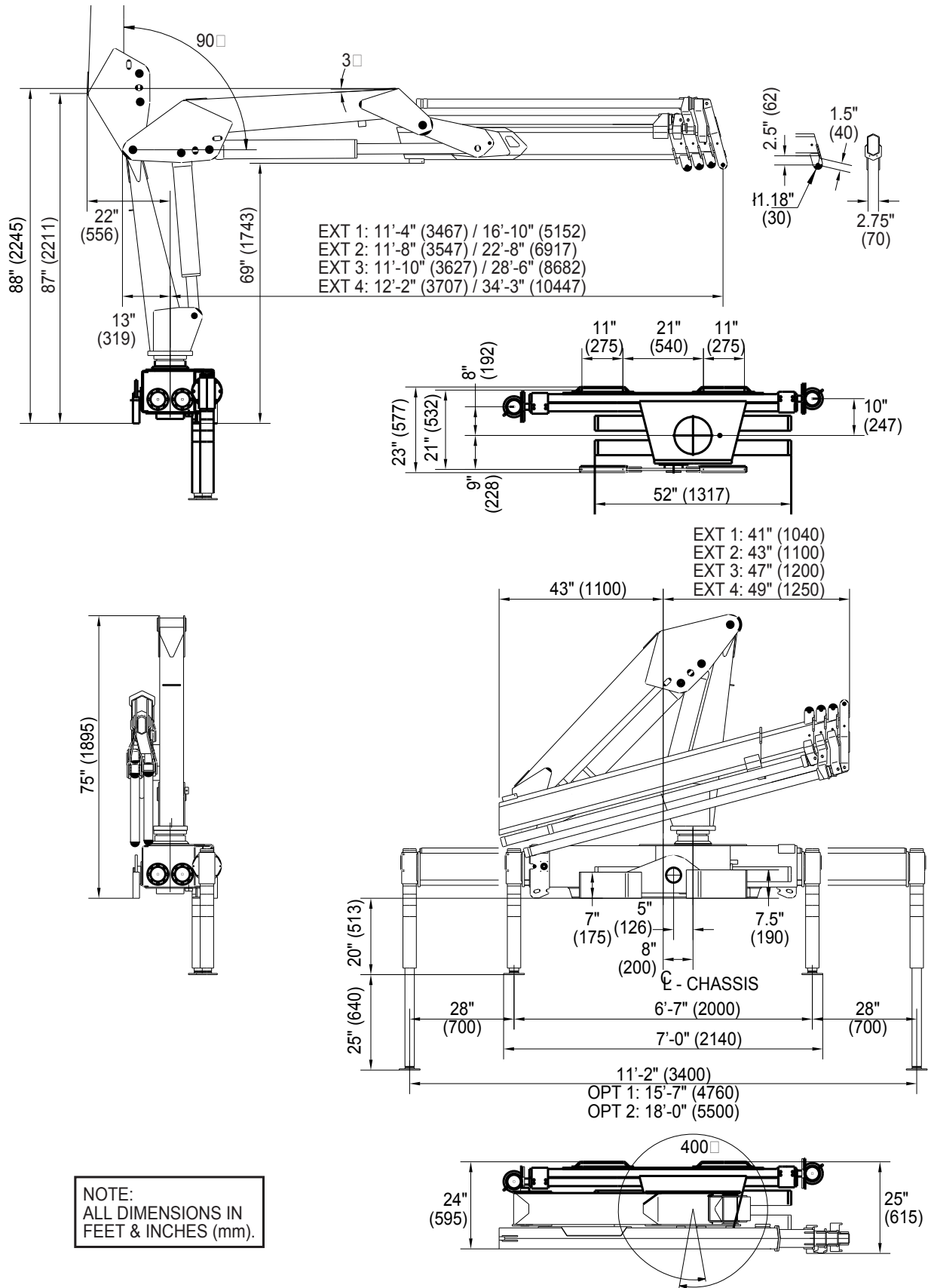

7.2a Technical Data (Domestic)

Performance	Unit	1 hyd ext	2 hyd ext	3 hyd ext	4 hyd ext
Crane Rating*	ft-lb	44,845	43,400	42,675	41,950
Max Horiz Reach	ft & in	16'-9"	22'-6"	28'-3"	34'-2"
Max Vert Reach	ft & in	23'-7"	29'-6"	35'-5"	41'-0"
Max. Capacity	lb	6505	6305	6105	5995
Max Cap@Max Reach	lb	2700	1905	1410	1070
Crane Weight**	lb	1910	2070	2220	2350
Hook Approach					
Vertical	ft & in	8'-2"	7'-10"	7'-6"	7'-2"
Horizontal	ft & in	2'-3"	2'-7"	2'-11"	3'-3"
Center of Gravity (Stored)					
Vertical	inches	23.0"	23.5"	24.0"	24.0"
Horiz (C/L Rot-Bridge)	inches	-1.0"	-1.0"	0.2"	0.5"
Stabilizer Pad Diameter	inches	5.5"	5.5"	5.5"	5.5"
Crane Storage Height	ft & in	6'-3"	6'-3"	6'-3"	6'-3"
Mounting Space***	inches	23.5"	23.5"	23.5"	23.5"
Rotation Torque	ft-lb	9945	9945	9945	9945
Rotation Angle	degrees	400	400	400	400
Optimum Pump Capacity	gpm (US)	7	7	7	7
System Pressure	psi	3840	3840	3840	3840
Oil Reservoir Capacity	gal	9.3	9.3	9.3	9.3
Stabilizer Extension Span					
Std-mnl out/hyd dn	ft & in	11'-2"	11'-2"	11'-2"	11'-2"
Weight	lb	275	275	275	275
Opt-mnl out/hyd dn	ft & in	15'-7"	15'-7"	15'-7"	15'-7"
Weight	lb	365	365	365	365
Opt-mnl out/hyd dn	ft & in	18'-0"	18'-0"	18'-0"	18'-0"
Weight	lb	430	430	430	430

Minimum Chassis Specifications

Front Axle Rating (GAWR)	lb	6000	6000	6000	6000
Rear Axle Rating (GAWR)	lb	12460	12460	12460	12460
RBM	in-lb	675,000	675,000	675,000	675,000

* Maximum Crane Rating (ft-lbs) is defined as that rated load (lbs) which when multiplied by its respective distance (ft) from centerline of rotation gives the greatest ft-lb value.

** Crane weight excluding stabilizers.

*** Additional mounting space of 11" will be required to provide crane rotational clearance.

7.2b Technical Data (Metric)

Performance	Unit	1 hyd ext	2 hyd ext	3 hyd ext	4 hyd ext
Crane Rating*	ton-m	6.2	5.9	5.9	5.8
Max Horiz Reach	m	5.1	6.9	8.6	10.4
Max Vert Reach	m	7.2	9.0	10.8	12.5
Max. Capacity	kg	2950	2860	2770	2720
Max Cap@Max Reach	kg	1225	865	640	485
Crane Weight	kg	866	939	1007	1066
Hook Approach					
Vertical	m	2.5	2.4	2.3	2.2
Horizontal	m	0.7	0.8	0.9	1.0
Center of Gravity (Stored)					
Vertical	mm	584.2	596.9	609.6	609.6
Horiz (C/L Rot-Bridge)	mm	-25.4	-25.4	5.1	12.7
Stabilizer Pad Diameter	mm	140	140	140	140
Crane Storage Height	m	1.9	1.9	1.9	1.9
Mounting Space	mm	597	597	597	597
Rotation Torque	ton-m	1.4	1.4	1.4	1.4
Rotation Angle	degrees	400	400	400	400
Optimum Pump Capacity	liters/min	26	26	26	26
System Pressure	bar	265	265	265	265
Oil Reservoir Capacity	liters	35	35	35	35
Stabilizer Extension Span					
Std-mnl out/hyd dn	m	3.4	3.4	3.4	3.4
Weight	kg	125	125	125	125
Opt-mnl out/hyd dn	m	4.76	4.76	4.76	4.76
Weight	kg	166	166	166	166
Opt-mnl out/hyd dn	m	5.5	5.5	5.5	5.5
Weight	kg	195	195	195	195

Minimum Chassis Specifications

Front Axle Rating (GAWR)	lb/kg	6000/2720	6000/2720	6000/2720	6000/2720
Rear Axle Rating (GAWR)	lb/kg	12460/5650	12460/5650	12460/5650	12460/5650
RBM	in-lb	675,000	675,000	675,000	675,000

* Maximum Crane Rating (ton-m) is defined as that rated load (ton) which when multiplied by its respective distance (m) from centerline of rotation gives the greatest ton-m value.

** Crane weight excluding stabilizers.

*** Additional mounting space of 280mm will be required to provide crane rotational clearance.

7.3a Working pressure-6/45 (domestic)

Working pressure on main-relief valve & port-relief valves

Function		Unit	
Main-relief valve		PSI	3842
Stabilizer legs	up	PSI	2537
	down	PSI	2537
Rotation cylinder		PSI	2175
Inner boom cylinder	up	PSI	3842
	down	PSI	1450
Outer boom cylinder	up	PSI	3842
	down	PSI	2175
Extension cylinder	out		P
	in		P

Opening pressure on load holding valves

Inner boom cylinder		PSI	4277
Outer boom cylinder		PSI	4350
Extension cylinder	retract	PSI	6235
	extend	PSI	3045

Pressure setting for load moment limitation

LMB		PSI	3697
-----	--	-----	------

7.3b Working pressure-6/45 (metric)

Working pressure on main-relief valve & port-relief valves

Function		Unit	
Main-relief valve		MPa	26.5
Stabilizer legs	up	MPa	17.5
	down	MPa	17.5
Rotation cylinder		MPa	15.0
Inner boom cylinder	up	MPa	26.5
	down	MPa	10.0
Outer boom cylinder	up	MPa	26.5
	down	MPa	15.0
Extension cylinder	out	MPa	P
	in	MPa	P

Opening pressure on load holding valves

Inner boom cylinder		MPa	29.5
Outer boom cylinder		MPa	30.0
Extension cylinder	retract	MPa	43.0
	extend	MPa	21.0

Pressure setting for load moment limitation

LMB		MPa	25.5
-----	--	-----	------

1 MPa = 10 bar

8.0 Repair

If your loader needs repair, always use an authorized IMT service center.

When ordering spare parts, please state:

- Loader type (6/45)
- Serial number
- The part number of the spare part required.

If you do not have a spare parts catalogue, you may place your order with your nearest IMT dealer.

IOWA MOLD TOOLING CO., INC.

BOX 189, GARNER, IA 50438-0189

TEL: 641-923-3711

TECHNICAL SUPPORT FAX: 641-923-2424