Manual # 99903549

Model 3.1/22 Crane

Revision Date 20030601



IOWA MOLD TOOLING CO., INC.

PO Box 189

Garner, IA 50438

Tel: 641-923-3711 FAX: 641-923-2424

Website: <http://www.imt.com>

Copyright © 2003 Iowa Mold Tooling Co., Inc.
All rights reserved

No part of this publication may be reproduced, stored in a retrieval system, or transmitted in any form or by any means, electronic, mechanical, photocopying, recording or otherwise without the prior written permission of Iowa Mold Tooling Co., Inc.

Contents

3.1/22 Manual Revisions	ii
-------------------------------	----

3.1/22 Instructions & Technical Specifications **3**

1. Introduction.....	4
2. Description of Loader Terminology	5
3. Control Valve Symbols.....	6
4. Operating Instructions.....	7
4.1a Safety Precautions.....	7
Electrical Safety.....	7
4.1b Engaging the PTO	8
4.1c Outrigger Functions	9
4.2 Unfolding the Loader.....	11
4.3 Using the Loader	12
4.4 After Operation.....	13
5. Maintenance.....	14
5.1 Lubrication Chart.....	14
5.2 Lubrication Diagram.....	15
6. Optional Extras	17
6.1 Manual Extensions	18
6.2 Winch - General	18
6.3 Fly-Jib - General.....	19
7. Lifting Capacity and Lifting Capacity Diagrams.....	20
7.1 Lifting Capacity Labels on the Loader	20
7.2 3.1/22 Lifting Capacity Diagrams	20
8. Technical Data	24
8.1 Loading Groups	24
3.1/22 Dimensional Drawings	25
3.1/22 Lifting Height.....	26
Technical Data 3.1/22.....	27
Center of Gravity.....	29
9. Working Pressure & Pump Performance	30
9.1 3.1/22 Pressure Settings.....	31
10. Description of the Hydraulic System	32
3.1/22 Hydraulic Diagram	33
11. Load Moment Limitation.....	34
12. Heavy Duty Lifting - HDL	34
13. Hoses and Hydraulic Pipes	35
14. Bleeding of Air	35
15. Repair.....	35

3.1/22 Manual Revisions

DATE	LOCATION	DESCRIPTION

CHAPTER 1

3.1/22 Instructions & Technical Specifications

In This Chapter

1. Introduction.....	4
2. Description of Loader Terminology	5
3. Control Valve Symbols	6
4. Operating Instructions	7
5. Maintenance.....	14
6. Optional Extras.....	17
7. Lifting Capacity and Lifting Capacity Diagrams.....	20
8. Technical Data	24
9. Working Pressure & Pump Performance	30
10. Description of the Hydraulic System	32
11. Load Moment Limitation	34
12. Heavy Duty Lifting - HDL.....	34
13. Hoses and Hydraulic Pipes	35
14. Bleeding of Air	35
15. Repair.....	35

1. Introduction

This instruction manual contains a description of the loader, instructions for operation as well as for maintenance and servicing of the loader.

It is very important that the owner and operator are familiar with the contents of this manual as well as the Safety Manual, the RCL Instruction Manual, and the Service Booklet prior to beginning loader operation.

It is also important to attend the recommended service overhauls. These service overhauls are designed to secure operational safety at all times and will also be of importance in case of warranty claims at a later stage, where great importance will be attached to whether these overhauls have been carried through by an authorized IMT service point or not.

As IMT is constantly developing and improving the loaders, your loader model may have been changed slightly since printing of this instruction manual.

2. Description of Loader Terminology

The loader is designed as a truck-mounted loader and therefore stationary mounting of the loader, mounting on agricultural tractors, special purpose vehicles etc. must only take place according to specific agreement with IMT.

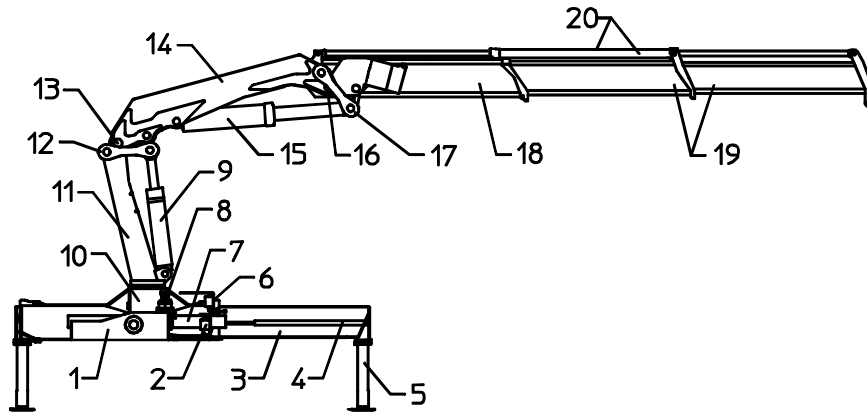

- | | | | |
|-----|----------------------------|-----|----------------------|
| 1. | Suspension Bridge | 11. | Mast |
| 2. | Hydraulic Control Valve | 12. | Link Arm, Inner Boom |
| 3. | Outrigger Arm | 13. | Hinge Pin |
| 4. | Extension Cylinder | 14. | Inner Boom |
| 5. | Outriggers | 15. | Outer Cylinder |
| 6. | Control Valve, Outriggers | 16. | Outer Boom Pin |
| 7. | Rotation System / Cylinder | 17. | Link Arm, Outer Boom |
| 8. | Planetary Gear Drive | 18. | Outer Boom |
| 9. | Inner Boom Cylinder | 19. | Extension |
| 10. | Base | 20. | Extension Cylinder |

3. Control Valve Symbols

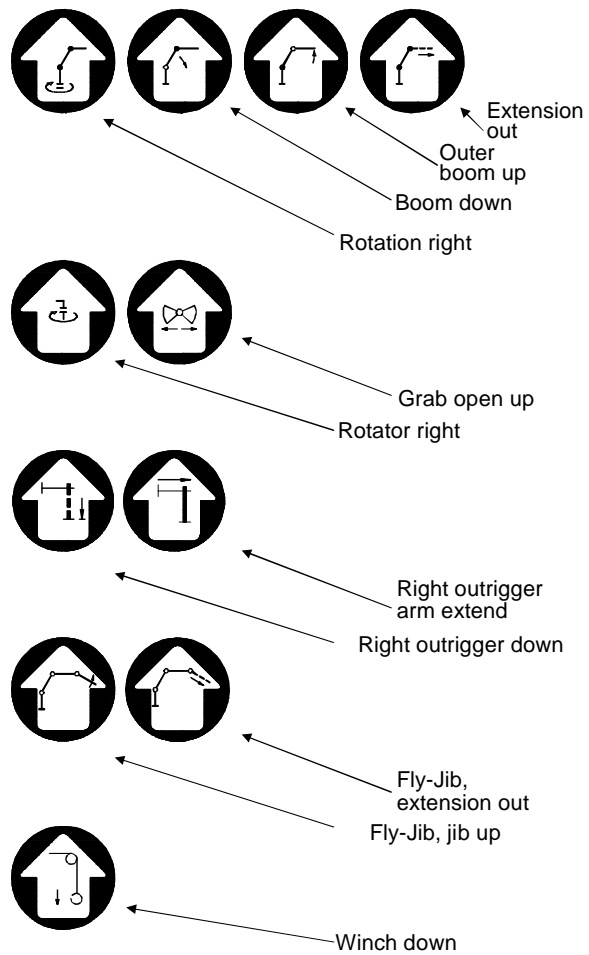

Each control valve has a label showing the functions of that particular valve.

4. Operating Instructions

4.1a Safety Precautions

Before loader operation the operator must make sure that the loader operation does not entail any unnecessary risk. Special attention must be paid to the following factors:

- 1 The ground must be sufficiently firm to take up the pressure from the outrigger legs. Use of steel plates under the foot plates are recommended in case of heavy lifting.
- 2 The ground must not be slippery (i.e. covered with ice or sand). When the parking brake is applied, the truck must be able to take up the horizontal forces from the loader without skidding or moving.
- 3 The truck must be parked in such a way that the operator has a complete view of the working area.
- 4 The operator must make sure that there are no electric wires or any other obstacles within the working radius of the loader.
- 5 The operator must inform any unauthorized persons that entry into the working area is not permitted.

Electrical Safety

DANGER

ELECTROCUTION HAZARD
 THIS CRANE IS NOT INSULATED
DEATH OR SERIOUS INJURY
 WILL RESULT FROM CONTACT
 OR INADEQUATE CLEARANCE

Maintain safe clearance from electrical lines.
 Allow for boom, electrical line, and loadline swaying.

This crane does not provide protection from contact
 with or proximity to an electrically charged conductor.

Maintain a clearance of at least 10 feet between
 any part of the crane, loadline or load and any electrical
 line carrying up to 50,000 volts (50 kV). *If electrical
 line voltage is unknown, assume maximum voltage
 and maintain a clearance of at least 45 feet.*

NOMINAL VOLTAGE, kV (Phase to Phase)	MINIMUM REQUIRED DISTANCE
to 50	10 feet
Over 50 to 200	15 feet
Over 200 to 350	20 feet
Over 350 to 500	25 feet
Over 500 to 750	35 feet
Over 750 to 1000	45 feet

70394444

For all work in the proximity of power plants or overhead wires the following general rules apply:

- 1** Due care and caution must be exercised in the planning, instructing for and execution of such work in order to prevent any risk or danger to persons, equipment or goods.
- 2** Any power supply plant, installation or wire must be considered live until the responsible power supply authority has provided a declaration to the opposite effect.
- 3** Any directions or guidelines from the responsible power supply authorities or public bodies should be strictly observed.

Any person or company directly responsible for the implementation of work in the proximity of overhead wires or electric power stations must make sure that all personnel involved in the execution of such work is familiar with any laws, rules or safety regulations, national as well as local, governing such work in the relevant country, territory or zone.

4.1b Engaging the PTO

- 1** Switch the change-over valve, if any, to “loader”.
- 2** Engage the PTO at low revolutions.
- 3** The engine revolution speed is regulated by means of the hand accelerator in order to ensure that the oil flow from the hydraulic pump corresponds to the recommended pump flow for the loader. When starting up in the cold, the oil should be allowed to circulate for a few minutes before operation starts.
- 4** Activate the parking brake of the vehicle.

Starting up:

- a** Pull out the emergency stop button – remember both sides of the loader, if necessary.
- b** Push the green button once, the “RUN” diode is lit and the safety system is activated.

4.1c Outrigger Functions

Push the yellow button twice and the “FUNC” and “F5” diodes are lit. After 2 seconds the diodes are turned off, but the outrigger function remains activated.

The outrigger function is activated. Complete the following items.

NOTE:

On certain loader models the outriggers are operated by means of the radio remote control. See the IRC Instruction Manual.

To return to loader functions,

Either activate one of the control levers of the loader’s control valve OR Push the yellow button twice. “FUNC” is lit and “F5” is turned off.

All loader functions are now active.

OUTRIGGERS

Release the outrigger lock and extend the outrigger arm completely, and lock it again. If the loader is equipped with a hydraulic extension function, it must only be used for extending and retracting the outrigger arm. The stability of the loader and the vehicle is based on the outriggers in their extreme position and the loader should only be used at maximum outrigger spread. The operator must know whether or not the vehicle is stable in the area in front of the outriggers (over the driver’s cab). Lower the outrigger legs just enough to raise the truck chassis a little in its suspensions. The tires must still have full contact with the ground. During loading of the truck the outrigger legs must be raised from time to time, to ensure that the truck carries the weight of the load. The outrigger legs are not designed to support this excessive load.





The best possible loader operation will be achieved when the vehicle is positioned as close to horizontal as possible. Therefore, the vehicle should be levelled to horizontal position by means of the outrigger legs before the loader is operated.

If the ground is not firm enough to take up the pressure of the outrigger legs, a steel plate, or the like must be placed under the foot plates.

4.2 Unfolding the Loader

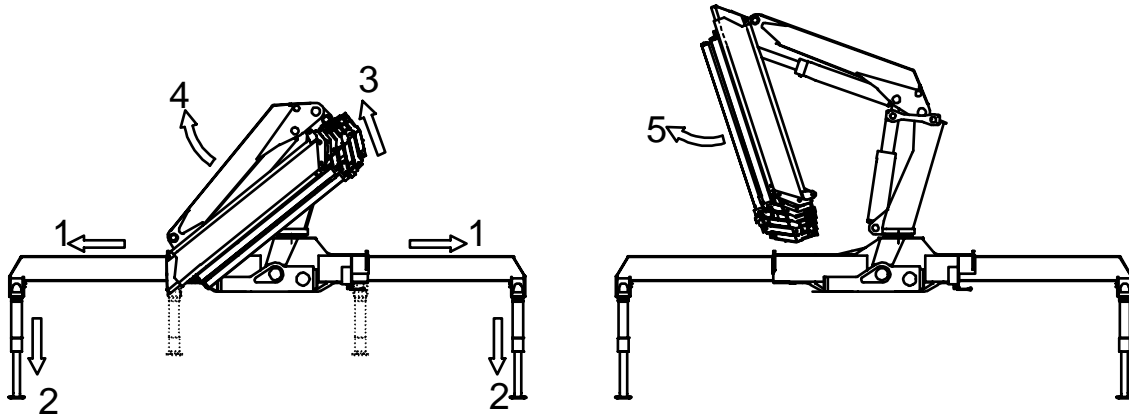

- 1 Extend the outrigger arms completely. This also goes for the separate traverse (if any).
- 2 Lower the outrigger legs according to **4.1c Outrigger Functions** (on page 9) above. This also goes for the separate traverse (if any).

NOTE

The outer boom must be raised (the “outer boom down” movement of the lever), so that the outer boom is released from the bracket.

- 3 Raise the main boom and thereby release it from the bracket. Raise the inner boom somewhat above horizontal, so that the outer boom can be moved freely downwards.
- 4 Raise the outer boom until it is free of the base.

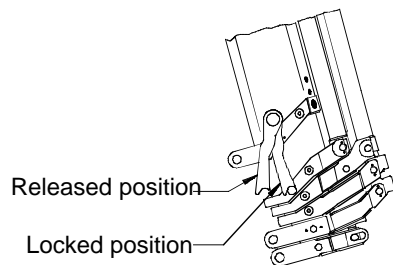

NOTE:

In case of loaders equipped with stop bracket on the outer boom, extend the outer boom extensions a little until the stop bracket is released.

4.3 Using the Loader

When the loader has been unfolded, work can start.

The lifting capacity of the loader is shown on the lifting capacity diagram on the loader and in the Loader Data. The capacity limits indicated must never be exceeded.

The loader is designed to *lift* loads vertically and therefore diagonal stresses should be avoided. Consequently it is not permitted to drag loads across the ground using the extension cylinders or the rotation system. These functions must only be activated once the load is free of the ground.

When mounting a grab, the total weight (grab, rotator and sand/contents) must not exceed the loader's lifting capacity at maximum reach. The grab/clamshell bucket must be used for moving excavated soil only. Excavating is not permitted.

CAUTION

Damage caused by improper loader operation will not be covered by the IMT warranty.

If the load is extended so far that the loader's lifting capacity is exceeded, the load moment increasing movements will be stopped. Please see the Instruction Manual on the RCL safety system.

The inner boom will slowly begin to sink in case of overloading. To stop this movement, the load should be brought closer towards the loader mast by means of the "extension retract"-movement.

WARNING

Never stand under the boom when the loader is working!

NOTE

Position the truck as closely to the load as possible, so that the load can be lifted on the shortest possible boom.

The rotation system should be operated with care, especially when the inner boom is at an acute angle with the outer boom.

The outriggers must not be activated when the loader is working.

Never drive off with a suspended load.

4.4 After Operation

The loader is folded up by reversing the procedure described in **4.2, *Unfolding the Loader*** (see "4.2 Unfolding the Loader" on page 11).

If the boom is parked on the truck platform it must be properly secured to prevent the boom from swinging out during transport. Also the operator must check that the total height does not exceed 13'-1" (4000 mm).

CAUTION:

It is very important to check that both the outrigger lock and safety lock are in place and properly secured, otherwise the outrigger arm might extend by itself during transport.



If the loader is equipped with swing-up outrigger legs they must also be secured in position before driving off. Before the vehicle is started, disengage the PTO and turn off the pump.

5. Maintenance

Careful maintenance of the loader is the best way to ensure reliable loader operation at all times.

At daily or weekly intervals, depending on frequency of loader application, complete the following maintenance steps:

- 1 Check the oil level in tank. The oil must be visible in the oil level glass of the tank when the loader is folded. If the loader is equipped with a planetary gear, check the oil level in it.

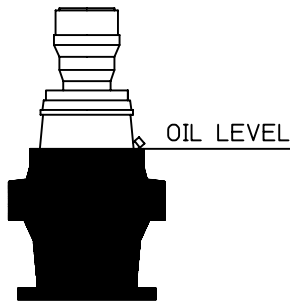

- 2 Make sure that any defects, damage or leaks are repaired at an authorized IMT service point as soon as they are discovered.
- 3 Check that loader is safely mounted to the truck.
- 4 Slide blocks and bushings reduce friction and therefore they are naturally subject to wear and tear. Replace slide blocks if too much free play is found in the boom system. Replace bushings before the metal components physically touch each other.
- 5 Check all hoses for defects and kinks.
- 6 Check that hooks, wire ropes, straps and the like are in good working order.
- 7 Check all lock pins and bolts for wear and tear.

Service overhauls should be undertaken in accordance with the Service Booklet. In case of any warranty claims at a later date, great importance will be attached to observance of these service overhauls.

5.1 Lubrication Chart

Lubrication Point	Frequency
Mast / planetary gear	After 50 hours of operation / 1 month (whichever occurs first)
Pinion ball bearings	After 50 hours of operation / 1 month (whichever occurs first)
Base bearings	After 20 hours of operation / 1 week (whichever occurs first)

Lubrication Point	Frequency
Extension system / slide blocks	After 50 hours of operation / 1 month (whichever occurs first)
Guide rail on extension cylinders	After 50 hours of operation / 1 month (whichever occurs first)
Pins / bolts	After 50 hours of operation / 1 month (whichever occurs first)
Outrigger arms	As required
Control valves and rod connections	Oil spray as required

5.2 Lubrication Diagram

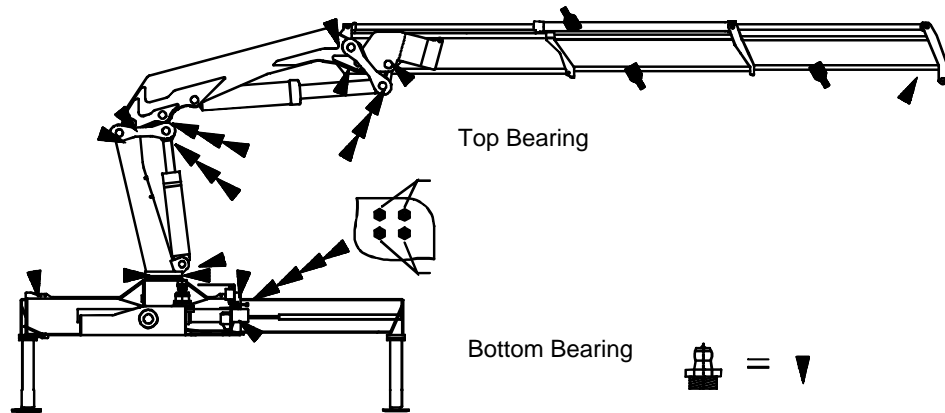

Example of a lubrication chart. For specific loader model, please see lubrication label on loader/Fly-Jib.

The rotation system should be activated and the loader swung from stop to stop several times within the whole rotation area at the same time as the bearings in the base are lubricated.

Requirements for hydraulic oil and lubrication grease are stated in the Service Booklet.

The telescopic extensions and the planetary gear are lubricated with a special grease, see the Service Booklet.

CAUTION

If the loader is not folded after use, make sure that all cylinders are completely retracted at least once a day. The protective oil coat on the piston rods is thus maintained, preventing corrosion from occurring on the chromium surface.

6. Optional Extras

Various extras are available with the loader:

- Fly-Jib
- Manual extensions
- Winch
- Pallet fork
- Grab / Rotator
- Remote control

Some loaders have optional extras such as manual extensions, winch, and Fly-Jib on a standard basis.

If these extras are standard, you should find technical data and pressure setting diagrams as well as lifting capacity diagrams for the Fly-Jib in this manual.

You should always consult an authorized IMT dealer/service point before mounting any kind of optional extra. This also applies to equipment already in your possession.

Please note: All optional extras on the loader must be protected by the safety system.

See the Instruction Manual – RCL Safety System.

CAUTION

Welding or drilling into the structural components of the loader will automatically invalidate any liability on the part of IMT.

6.1 Manual Extensions

When working with manual extensions, please note:

CAUTION

Never exceed the indicated load limits for manual extensions.

Use great caution when activating the rotation system during work with manual extensions.

If the loader has manual extensions or other extras, reduce the lifting capacity of the loader by the weight of the extras.

Always check that lock bolts are fitted correctly with a pin.

If the loader is fitted with several extensions and a certain lifting job requires the use of one extension only, use the extension with the largest box profile.

Only pull out the manual extensions when the outer boom is as close to horizontal as possible.

If the outer boom is pointing downwards when the lock bolt is removed, the extensions will drop out at uncontrollable speed. This may ruin the stop at the risk of resulting in personal injury.

The load must not be extended from the stop, i.e., the extension lock pins must always remain in place.

6.2 Winch - General

Refer to the parts manual for winch information. The winch is protected by the safety system. Refer to the RCL Safety System Instruction Manual.

6.3 Fly-Jib - General

The Fly-Jib is protected against overloading by the RCL Safety System in the entire lifting area. See the Instruction Manual – RCL Safety System.

CAUTION

The load limits indicated on the lifting capacity diagram of the manual extensions must never be exceeded.

When the Fly-Jib is dismounted, all quick-release couplings must be equipped with dust caps in order to avoid penetration of dirt in the hydraulic system.

Also carefully fit the dummy plug in the socket on the loader, otherwise the safety system will indicate an error. Avoid damaging the plug when mounting and dismounting. Keep the dummy plug in the driver's cab when not in use.

When the Fly-Jib is mounted, always check that the lock bolt is fitted correctly with a pin.

Always operate the loader in a calm and considerate way when working with a Fly-Jib. Special care should be taken when operating the rotation movement.

7. Lifting Capacity and Lifting Capacity Diagrams

7.1 Lifting Capacity Labels on the Loader

From the factory, the loader is equipped with lifting capacity labels for the loader as well as for the optional extras, if any (manual extensions, Fly-Jib). Like all labels on the loader, these labels must be intact and legible.

If a label has been damaged or removed, you can get a new one from IMT. Use the part number at the bottom of the label, if any, or see the spare parts catalog.

7.2 3.1/22 Lifting Capacity Diagrams

As a supplement to the loader's lifting capacity labels, the Loader Data contain load and lifting capacities of the different K-versions in standard applications, i.e. special applications and customized loaders and options are not taken into consideration.

In these cases we refer to the supplementary documentation delivered and/or the lifting capacity labels on the loader.

The lifting capacity limits indicated must never be exceeded.



IOWA MOLD TOOLING CO., INC.
 BOX 189 • GARNER • IA • 50438 • 641-923-3711

Model 3.1/22K1

- Working loads will be limited to those shown. Deduct the weight of load handling devices.
- Before lift is made, stability must be checked per SAE J765A.

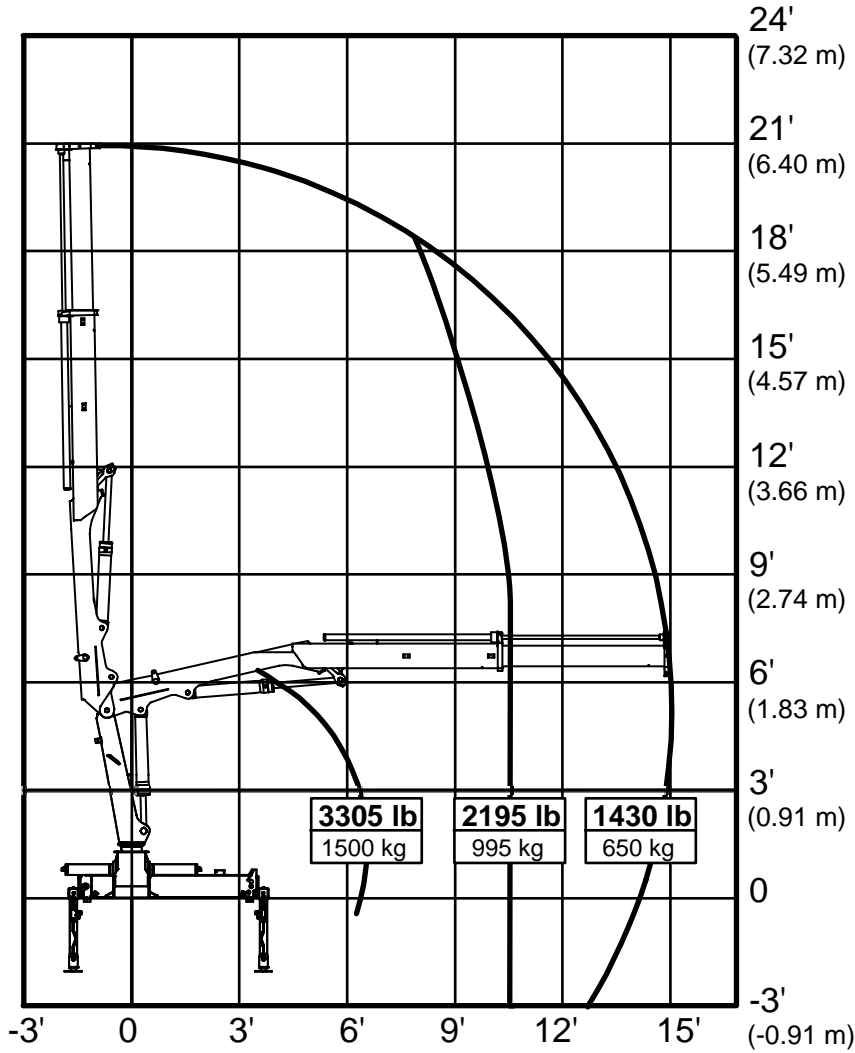

70396327

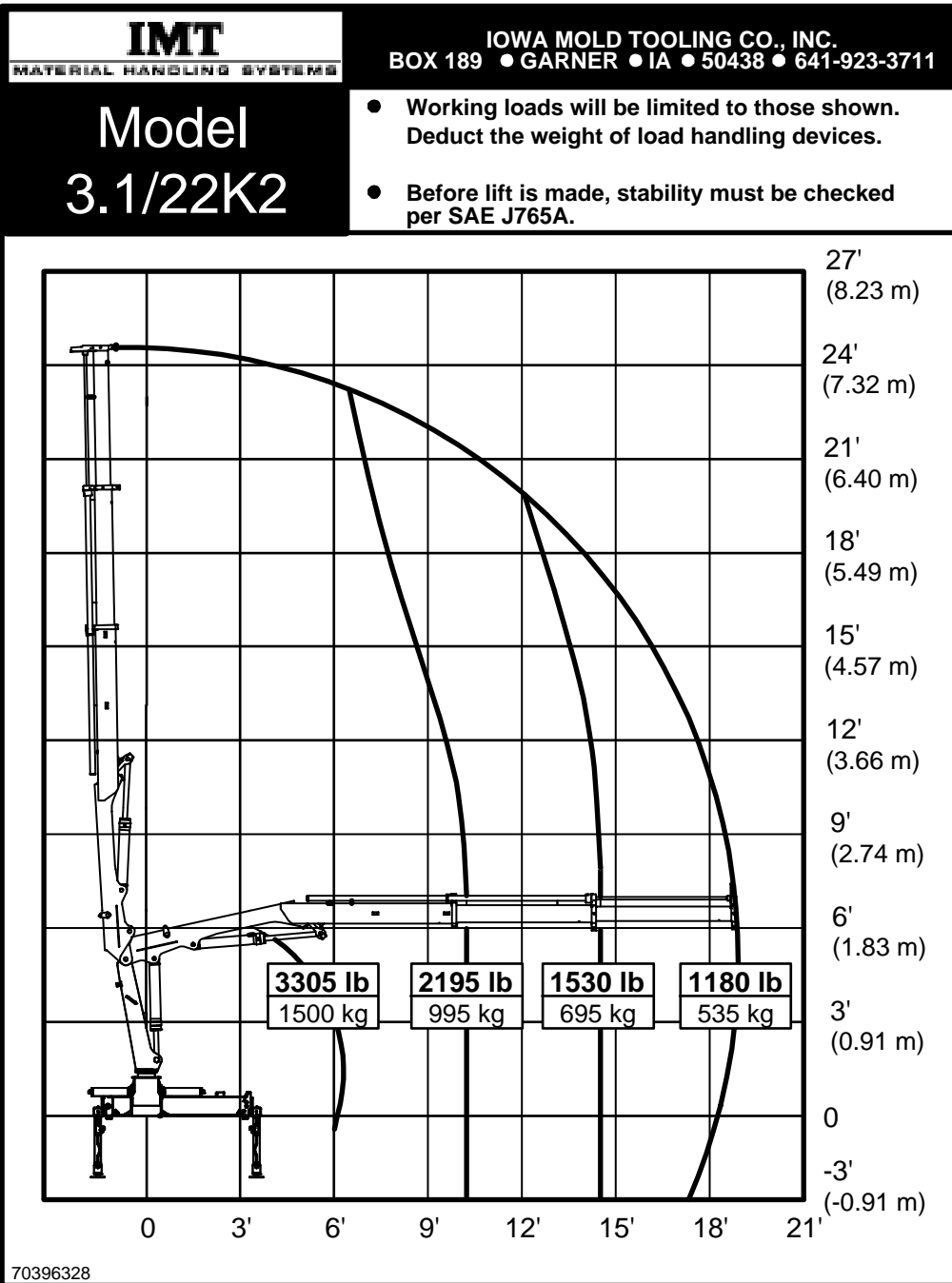

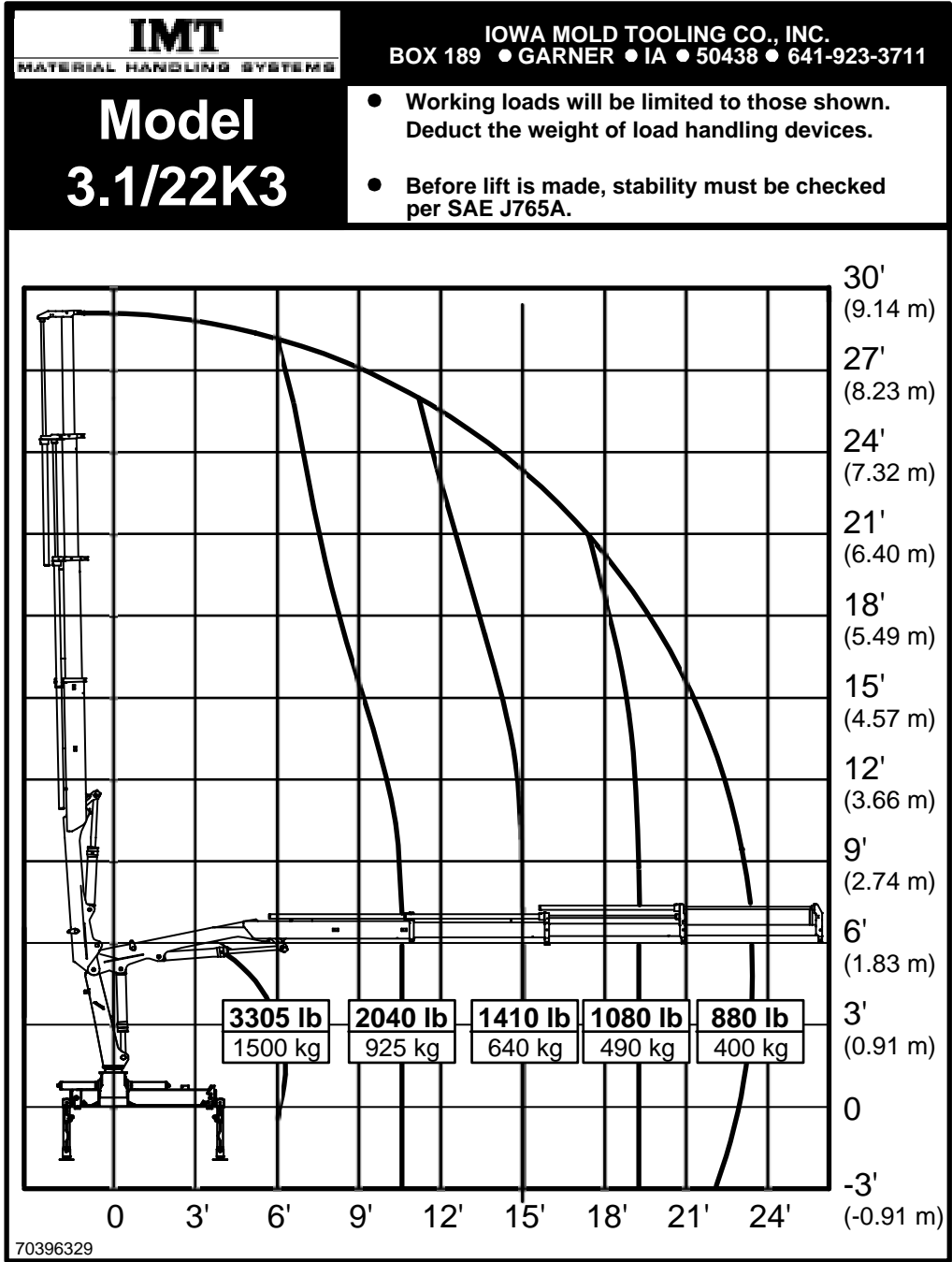

8. Technical Data

The Loader Data contain tables with technical data on loader and Fly-Jib respectively, if a Fly-Jib is available as standard.

8.1 Loading Groups

Different loader applications imply different types of stress to the loader construction, and consequently the loaders are divided into loading groups according to application.

In the standard application, the loader belongs to a certain loading group indicated by the last digit of the loader type denomination. (i.e.: 2823-K2 means a 2820-K2 loader classified in loading group B3).

If the loader is stationary or the working speed increased, for instance by means of a dual circuit hydraulic system (2 pumps), the load moment of the loader is reduced.

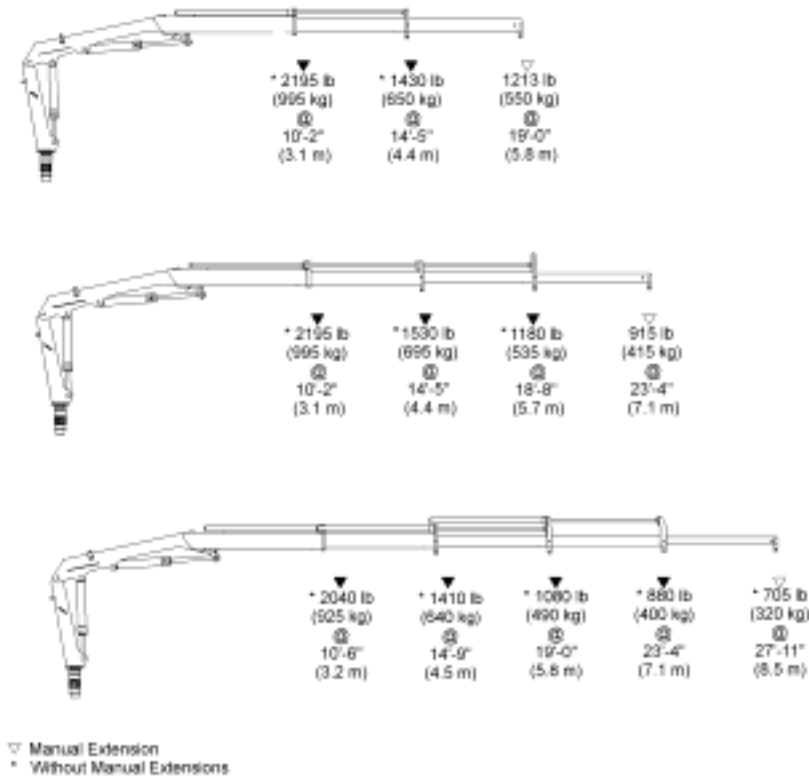

3.1/22 Dimensional Drawings

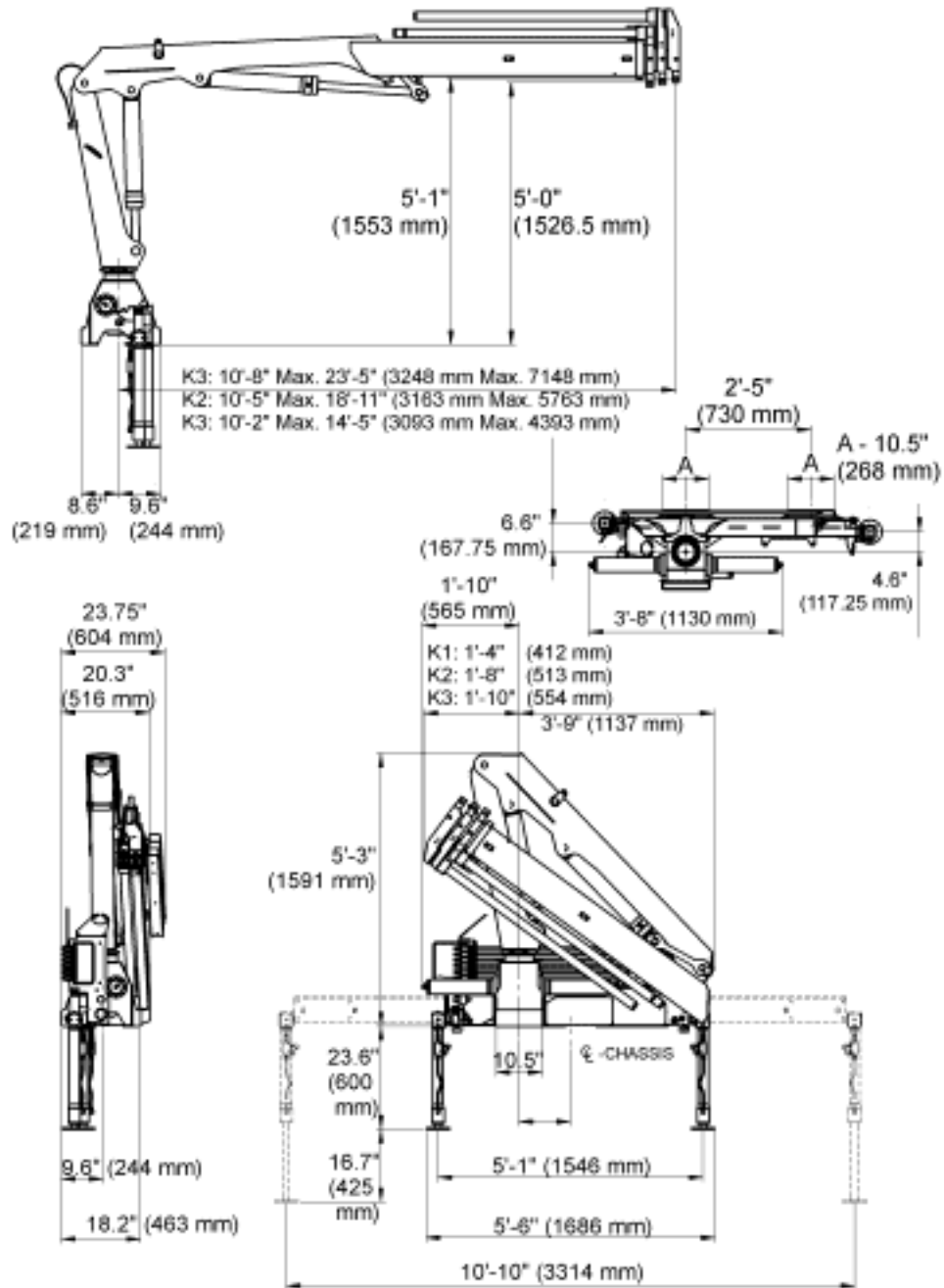

3.1/22 Lifting Height

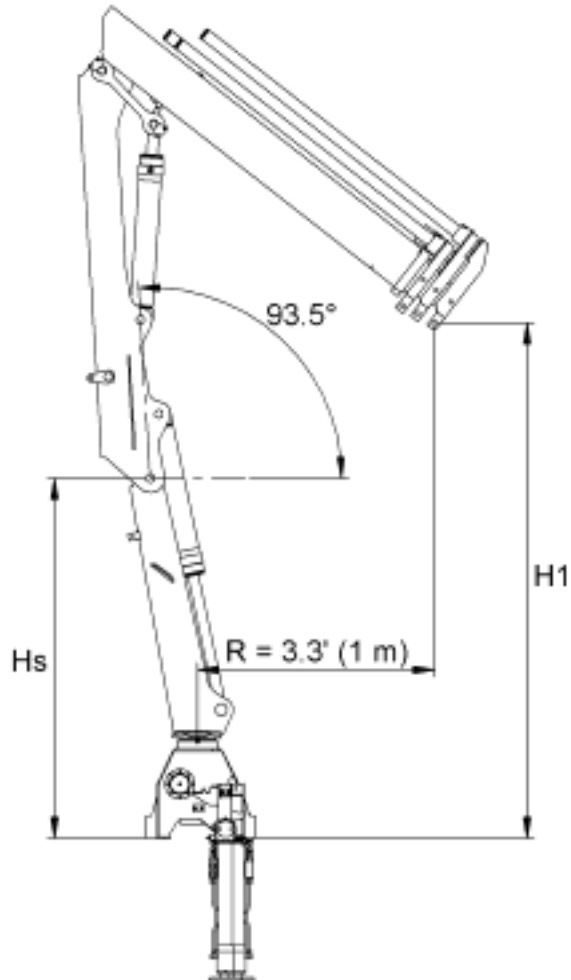

	Hs	H1
K1	5'-0" (1.53 m)	7'-2" (2.18 m)
K2	5'-0" (1.53 m)	7'-7" (2.32 m)
K3	5'-0" (1.53 m)	8'-0" (2.45 m)

Technical Data 3.1/22

PERFORMANCE

	K1	K2	K3
Load Moment	22,420 ft-lb (3.1 tm)	22,420 ft-lb (3.1 tm)	21,700 ft-lb (3.0 tm)
Hydraulic Reach	14'-5" (4.39 m)	18'-11" (5.76 m)	23'-5" (7.15 m)
Hydraulic Telescopic Movement	0.05" (1.3 mm)	0.1" (2.6 mm)	0.15" (3.9 mm)
Reach with Manual Extensions	8'-10" (5.75 m)	23'-5" (7.13 m)	27'-11" (8.50 m)
Hydraulic Lifting Capacity	2,195 lb @ 10'-2" (995 kg @ 3.1 m) 1,433 lb @ 14'-5" (650 kg @ 4.4 m)	2,195 lb @ 10'-2" (995 kg @ 3.1 m) 1,530 lb @ 14'-5" (695 kg @ 4.4 m) 1,180 lb @ 18'-8" (535 kg @ 5.7 m)	2,040 lb @ 10'-6" (925 kg @ 3.20 m) 1,410 lb @ 14'-9" (640 kg @ 4.5 m) 1,080 lb @ 19'-0" (490 kg @ 5.8 m) 882 lb @ 23'-4" (400 kg @ 7.1 m)
Rotation Torque	3,183 ft-lb (440 kg-m)	3,183 ft-lb (440 kg-m)	3,183 ft-lb (440 kg-m)
Rotation Angle	0 - 370 °	0 - 370 °	0 - 370 °
Max. heel at max. load moment	4°	4°	4°

MEASUREMENTS - MODELS K1, K2, K3

Height above chassis when folded	5'-3" (1591 mm)
Width when folded	5'-7" (1702 mm)
Length without extra valves	1'-8" (516 mm)
Outrigger spread, standard	10'-10" (3314 mm)

WORKING SPEED - MODELS K1, K2, K3

Rotation speed	20 deg/sec
Lifting speed at maximum reach	2'-8"/second (0.8 m/second)

WEIGHTS

	K1	K2	K3
Standard loader w/o outrigger legs	1,102 lb (500 kg)	1,202 lb (545 kg)	1,290 lb (585 kg)
Mounting bolts	44 lb (20 kg)	44 lb (20 kg)	44 lb (20 kg)
Oil in base and cylinders	40 lb (18 kg)	42 lb (19 kg)	44 lb (20 kg)
Standard tank with oil	51 lb (23 kg)	51 lb (23 kg)	51 lb (23 kg)

POWER CONSUMPTION / PUMP PERFORMANCE

	K1	K2	K3
Working pressure	3990 psi (27.5 MPa)	4206 psi (29.0 MPa)	4206 psi (29.0 MPa)
Pump performance	3.9 gpm (15 l/min)	3.9 gpm (15 l/min)	3.2 gpm (12 l/min)
Power consumption	9.25 hp (6.9 KW)	9.8 hp (7.3 KW)	7.8 hp (5.8 KW)
Oil capacity in base	2.4 gal (9 l)	2.4 gal (9 l)	2.4 gal (9 l)
Oil capacity in separate tank	5.3 gal (20 l)	5.3 gal (20 l)	5.3 gal (20 l)

Center of Gravity

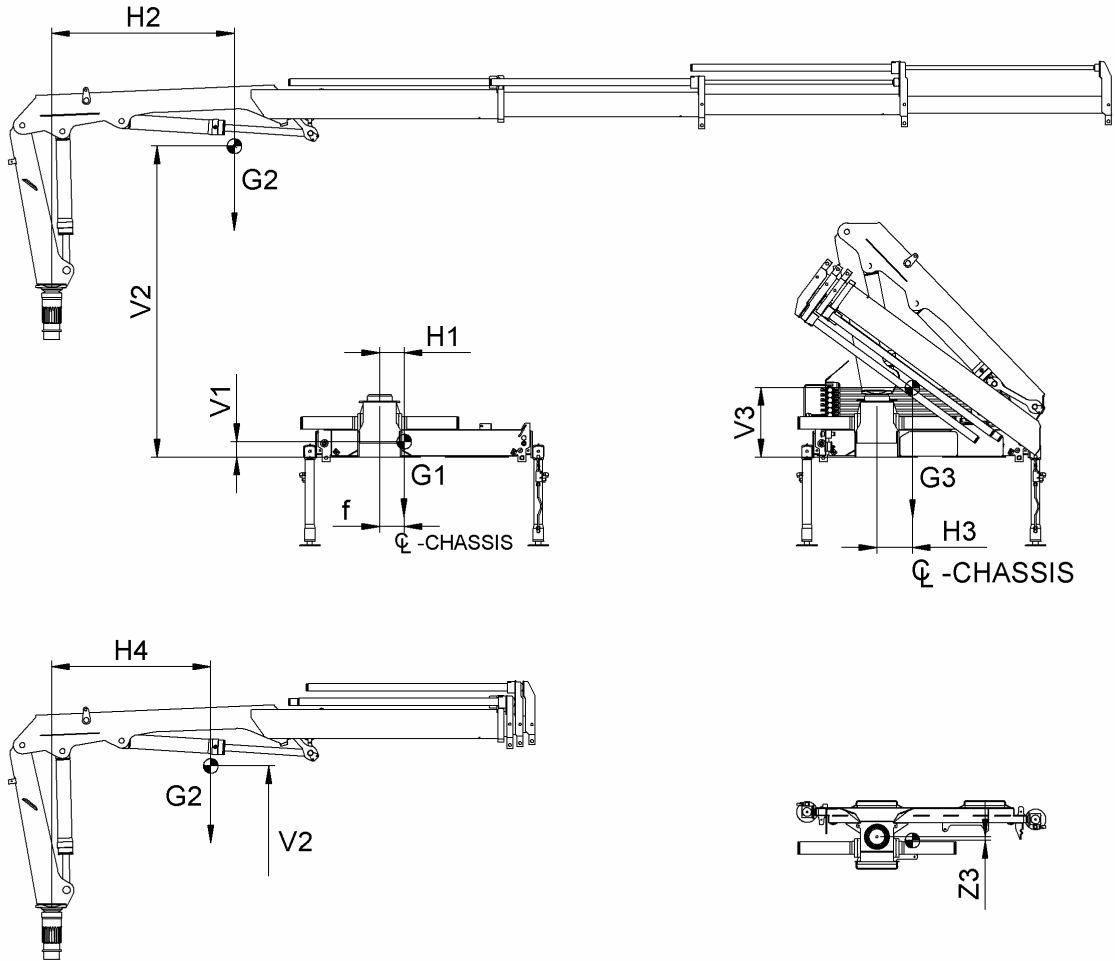

MODEL	V1	V2	V3	H1	H2	H3
K1	4.13" (105 mm)	4'-7" (1400 mm)	1'-6" (470 mm)	6.5" (165 mm)	4'-0" (1235 mm)	10.0" (255 mm)
K2	4.13" (105 mm)	4'-9" (1445 mm)	1'-7" (485 mm)	6.5" (165 mm)	5'-6" (1670 mm)	9.8" (250 mm)
K3	4.13" (105 mm)	4'-10" (1480 mm)	1'-8" (500 mm)	6.5" (165 mm)	7'-1" (2170 mm)	9.4" (240 mm)

MODEL	H4	Z3	f	G1	G2	G3
K1	3'-6" (1075 mm)	-0.2" (-5 mm)	11.8" (300 mm)	8.6" (219 mm)	11.3" (286 mm)	1'-8" (505 mm)
K2	4'-1" (1250 mm)	0.4" (10 mm)	11.8" (300 mm)	8.6" (219 mm)	12.8" (326 mm)	1'-9" (545 mm)
K3	4'-7" (1390 mm)	1.0" (25 mm)	11.8" (300 mm)	8.6" (219 mm)	14.4" (366 mm)	1'-11" (585 mm)

9. Working Pressure & Pump Performance

The working pressure must only be set with a calibrated pressure gauge by an authorized IMT service point.

The working pressure is checked during the annual service overhaul and in case of any major repairs.

The procedure for checking and setting of load-holding valves is described in the Service Information binder. All adjustable valves will be re-sealed after pressure setting adjustment.

CAUTION

Please note that any warranty obligations on the part of IMT will be invalidated if the conditions stated in this manual are not complied with.

9.1 3.1/22 Pressure Settings

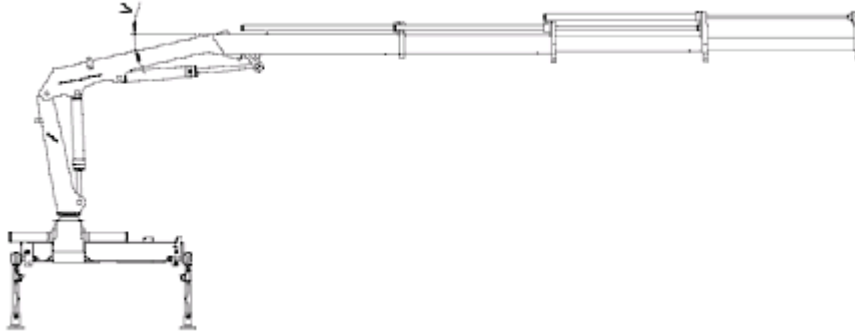

Basic position during test and adjustment of valves
 Outer boom in horizontal position
 $V = 12.5^\circ$

Working Pressure on Main-Relief Valve and Port Relief Valves

Function		Port	Loading Group		
			02	03	04
Main Relief Valve		K1		3988 psi (27.5 Mpa)	
		K2-K3		4206 psi (29.0 Mpa)	
Outrigger Legs	down	A-port		2175 psi (15 MPa)	
	up	B -		2175 psi (15 MPa)	
	down	A -		2175 psi (15 MPa)	
	up	B -		2175 psi (15 MPa)	
Extension cylinders	retract	A -		P	
	extend	B -		1813 psi (12.5 MPa)	
Outer boom cylinder	up	A -		3988 psi (27.5 MPa)	
	down	B -		2538 psi (17.5 MPa)	
Inner boom cylinder	up	A -		4351 psi (30 MPa)	
	down	B -		1813 psi (12.5 MPa)	
Rotation system	left	A -		2538 psi (17.5 MPa)	
	right	B -		2538 psi (17.5 MPa)	

Opening Pressure on Load Holding Valves

Outer boom cylinder	4569 psi (31.5 MPa)
Inner boom cylinder	3988 psi (27.5 MPa)
Extension cylinder C1-V1	2175 psi (15.0 MPa)
Extension cylinder C2-V2	5076 psi (35.0 MPa)

Maximum Pump Performance

Pump performance K1+K2	3.17 - 3.96 gal/min (12-15 l/min)
Pump performance K3	3.17 gal/min (12 l/min)

1 MPa = 1 Bar

10. Description of the Hydraulic System

The valve block of the loader is of the "stack" type, i.e., it is made up of a number of separate control valves. This ensures great flexibility and low maintenance costs.

A main relief valve is fitted in the inlet section of the valve block to ensure that the oil pressure in the pump line does not exceed the permissible limit. This valve is adjustable and must always remain sealed.

Port relief valves are mounted at the ports of the individual control valves in order to limit the pressure in the individual circuits. Normally the port relief valves will be pre-set and unadjustable.

The inner boom, outer boom and extension cylinders are mounted with load holding valves with the following functions:

- 1 Protection of cylinders against excessive pressure
- 2 Checking of the lowering speed of the boom
- 3 Maintaining the boom in position during operations where a fixed boom position is required.
- 4 Locking the boom and maintaining the load in position in case of hose or pipe rupture.

The outrigger cylinders are equipped with a piloted check valve, which locks the cylinder in case of damage to the hydraulic system.

CAUTION

The main relief valve, the load holding valves, the dump valve and the external relief valve are sealed. If these seals are broken or removed, the IMT warranty will automatically be invalidated. Therefore, it is in your own interest to have the seals checked from time to time and to make sure that they are replaced by an authorized IMT service point, should they be damaged.

Any modification or alteration to the hydraulic system must be in accordance to specific agreement with IMT and such alterations should always take place at an authorized IMT service point.

3.1/22 Hydraulic Diagram

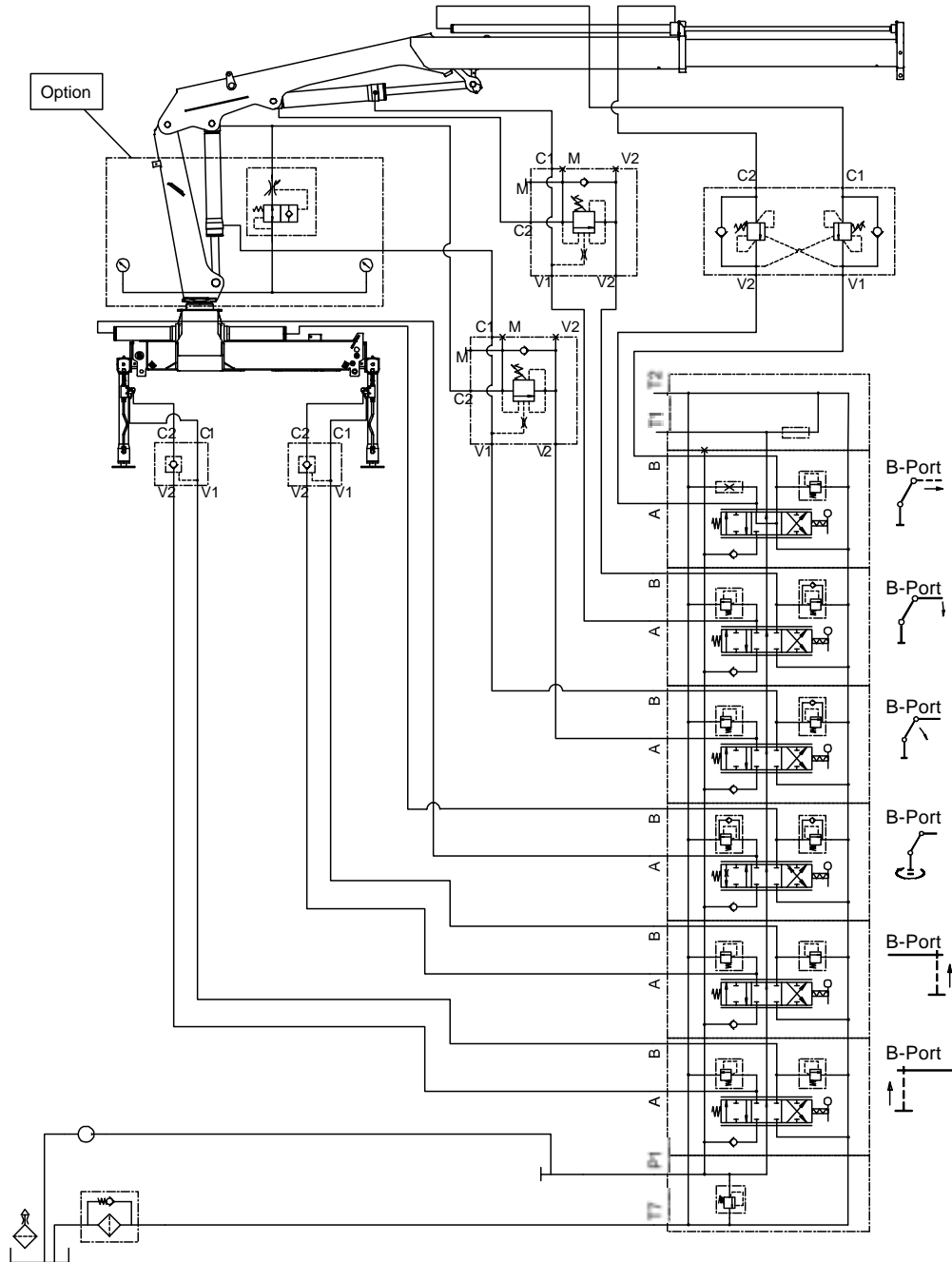

11. Load Moment Limitation

The loader is equipped with a load moment limitation system (LMB). This system ensures that the permissible load moment is never exceeded, irrespective of the operator's doings.

However, it is important to keep in mind that the LMB-system does not necessarily ensure sufficient vehicle stability. Before starting to work with the loader, the operator must always make sure that the vehicle is stable in the entire rotation area of the loader.

However, if the loader is equipped with an EVS-system (Electronic Vehicle Stability), the stability of the vehicle is ensured in the entire working area, because the system is constantly checking the vehicle, and immediately stopping the load moment increasing movement in case of instability, irrespective of the operator's doings.

The LMB-system is described in the Instruction Manual - RCL Safety System. The operator must be familiar with this manual.

12. Heavy Duty Lifting - HDL

If the loader is equipped with a Heavy Duty Lifting (HDL) system, an increased lifting capacity is obtained, although at reduced speed.

When the loader reaches its normal lifting capacity limit, the HDL-system will automatically couple in, irrespective of the operator's doings, and the oil flow to the control valve will be reduced to approx. 20% of the normal oil flow. At the same time the loader lifting capacity is increased by approx. 10% in the entire working area of the loader.

When the HDL-system couples in, the operator will be able to continue extending the load without interruption, although at reduced speed.

If the load moment is reduced to the permitted load limits again, the HDL-system will increase the oil flow to normal and the working speed will increase again.

However, the automatic disconnection implies that all control levers have been into neutral position *at the same time* as the load moment has been reduced to the permitted load limit.

See the section titled "Heavy Duty Lifting, HDL" in the RCL Safety System Instruction Manual.

13. Hoses and Hydraulic Pipes

The hoses must comply with the DIN 20 022 2SN standards.

The pipes are manufactured in St.35.4C-NBK.

14. Bleeding of Air

If for some reason air has entered into the hydraulic system, the loader is bled as follows:

- 1 Raise and lower each outrigger leg twice.
- 2 Extend and retract the inner boom cylinder twice.
- 3 Extend and retract the outer boom cylinder twice with the inner boom pointing downwards and twice with the inner boom pointing upwards.
- 4 Extend and retract the extension cylinder twice with the outer boom cylinder pointing almost vertically upwards and twice with the outer boom cylinder pointing almost vertically downwards.

15. Repair

If you discover defects, damage or leaks they should be repaired as soon as possible. Always take your repairs to an authorized IMT service point. Repairs to the hydraulic system must only be made by an authorized service point.

When you order spare parts for your loader, please state:

- Loader type
- Loader serial number

This information can be found in this instruction manual or stamped into the metal plate on the backside of the loader mast.