

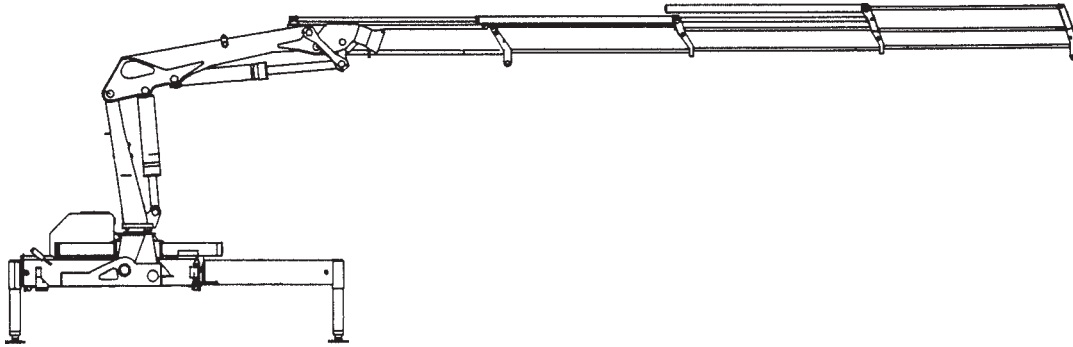

Model 15/113

Instruction Manual



NOTE

Read and understand this manual, the
IMT Operators Crane Safety Manual
and Safety Manual Supplement
before operating or maintaining your crane.

IOWA MOLD TOOLING CO., INC.

BOX 189, GARNER, IA 50438-0189

TEL: 641-923-3711

TECHNICAL SUPPORT FAX: 641-923-2424

Iowa Mold Tooling Co., Inc. is an Oshkosh Corporation company.

TABLE OF CONTENTS

TABLE OF CONTENTS	2	8.0 TECHNICAL DATA	16
REVISIONS LIST	2	REFERENCE DIMENSIONS	16
1.0 INTRODUCTION	3	TECHNICAL DATA (Domestic)	17
2.0 LOADER TERMINOLOGY	3	TECHNICAL DATA (Metric)	18
3.0 CONTROL VALVES, SYMBOLS	4	9. WORKING PRESSURE/PERFORMANCE	19
4.0 OPERATING INSTRUCTIONS	5	WORKING PRESSURE-15/113 (Domestic units) ..	19
4.1 START UP	5	WORKING PRESSURE-15/113 (Metric units)	20
4.2 USING THE LOADER	8	10. HYDRAULIC SYSTEM	21
4.3 AFTER OPERATION	9	10.1 DESCRIPTION	21
5. MAINTENANCE	9	10.2 HYDRAULIC DIAGRAMS	21
5.1 LUBRICATION INTERVALS	9	STANDARD HYDRAULIC DIAGRAM	22
5.2 LUBRICATION CHART	10	11. BLEEDING OF AIR	23
6.0 OPTIONS	10	12. REPAIR	23
6.1 MANUAL EXTENSIONS	11	13. SERVICE	23
7.0 LIFTING CAPACITY DIAGRAMS	11	13.1 FIRST SERVICE OVERHAUL	23
7.1 CAPACITY CHARTS	11	13.2 ANNUAL SERVICE OVERHAUL	24
7.2 CAPACITY DIAGRAMS	11	13.3 RECOMMENDED HYDRAULIC OIL TYPES .	24
CAPACITY CHART-15/113K1	12	13.4 RECOMMENDED LUBRICANTS	24
CAPACITY CHART-15/113K2	13		
CAPACITY CHART-15/113K3	14		
CAPACITY CHART-15/113K4	15		

REVISIONS LIST

DATE	LOCATION	DESCRIPTION OF CHANGE
-	-	-
20061113	1	NEW OWNERSHIP STATEMENT
20071113	PG 12-15, 16-18	ECN 9000 - REVISED CAPACITY ART, TECHNICAL DRAWING, AND SPECS FOR CONSISTENCY
20120223	THROUGHOUT	ECN 11628 - UPDATE STABILIZER WORDING

1.0 INTRODUCTION

This instruction manual contains a description of the loader, instructions for operation, maintenance and repair of the loader. The instruction manual includes the following sections:

Sections 1 through 8 contain general instructions for the daily operation of the loader.

Sections 9 through 13 are primarily aimed at operators, installation and maintenance personnel and contain instructions for installation, adjustment, inspection, and maintenance.

It is important that you familiarize yourself with the contents of this manual before putting the loader into operation. The same applies to any operators and maintenance personnel of the loader. Also familiarize yourself with any other manuals or instructions which accompanied the loader.

It is also important to follow the recommended service schedules. These service overhauls aid in operational safety. They will also be of importance in the event of any warranty claims since IMT will attach great importance to whether these overhauls have been carried through by an authorized service center or not.

Due to continuous development and improvements, your loader model may have been changed slightly since the printing of this instruction manual.

2.0 LOADER TERMINOLOGY

The loader is designed as a truck mounted loader and therefore stationary mounting of the loader, mounting on agricultural tractors, special purpose vehicles and the like may only be performed according to specific agreement with IMT.

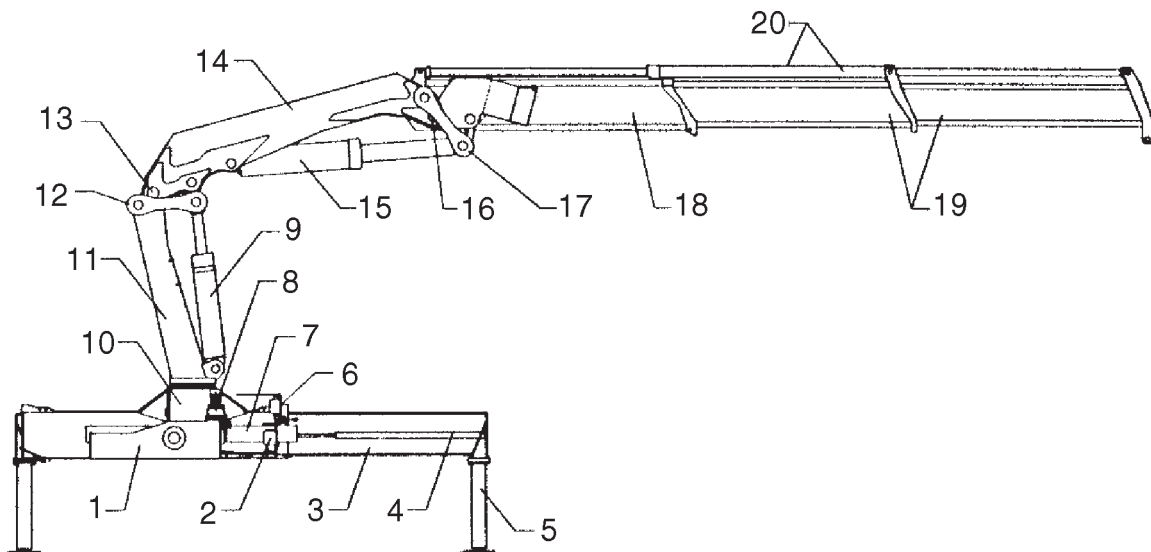

- | | |
|----------------------------------|--------------------------|
| 1. Suspension traverse | 11. Mast/Column |
| 2. Control valve, loader | 12. Link arm, Inner boom |
| 3. Stabilizer beam/arm | 13. Hinge pin |
| 4. Stabilizer extension cylinder | 14. Inner/Main boom |
| 5. Stabilizer leg | 15. Outer/Jib cylinder |
| 6. Control valve, stabilizer | 16. Outer/Jib pin |
| 7. Rotation/Slewing cylinder | 17. Link arm, outer/jib |
| 8. Planetary gear | 18. Outer boom/Jib |
| 9. Inner Boom cylinder | 19. Extension booms |
| 10. Base | 20. Extension cylinder |

3.0 CONTROL VALVES, SYMBOLS

Each control valve is labeled showing the functions of that particular valve.

Control levers should always be operated steadily and smoothly to avoid unnecessary strain on the loader.

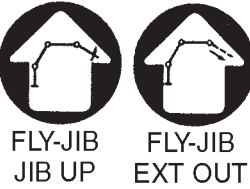
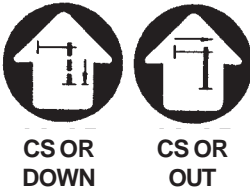
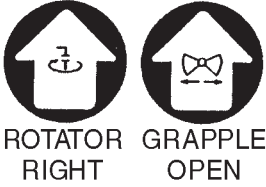
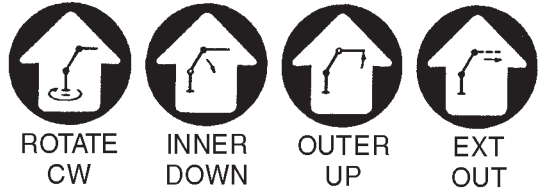

4.0 OPERATING INSTRUCTIONS

4.1 START UP

WARNING

Prior to operation, read and understand the IMT Operators Crane Safety manual and any other safety manuals which accompanied the loader.

Before start up the operator must make sure that loader operation does not entail any unnecessary risk. Special attention must be paid to the following factors:

1. The ground must be sufficiently firm to accept the pressure from the stabilizer legs. In case of heavy lifts we recommend the use of steel plates under the stabilizer foot plates.
2. The ground must not be slippery (i.e., covered with ice, sand, etc.). After the driver has applied the parking brake, the truck must be able to accept the horizontal forces from the loader without skidding or moving.
3. The truck must be parked in such a manner that the operator has a complete and unobstructed view of the field of operation.
4. The operator must make sure that there are no electric wires or any other obstacles within the working radius of the loader.
5. The operator must inform any unauthorized persons that entry into the working area is not permitted.

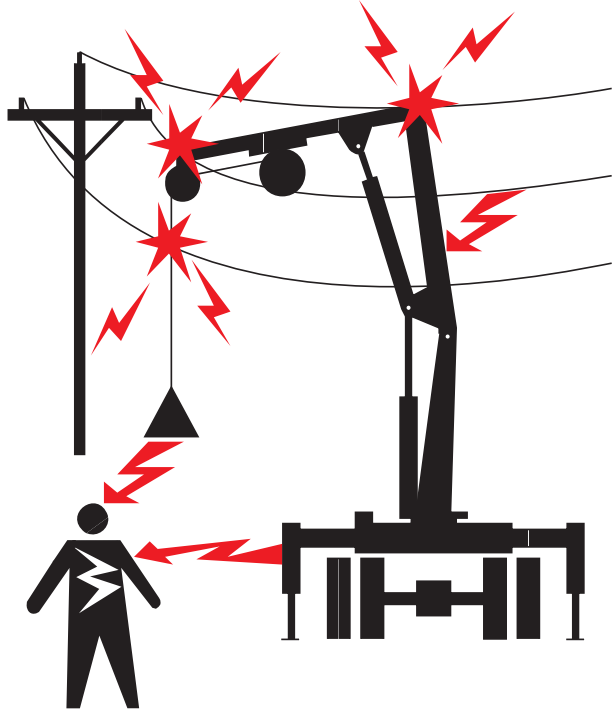
	
<h3>Electrocution Hazard</h3> <p>Crane is not insulated</p> <p>NEVER approach or contact power lines with any part of this equipment or load.</p> <p>Keep 50 feet away from any power line if voltage is not known.</p> <p>Keep 20 feet away from any power line 350 kilovolts or less.</p> <p>Account for swaying motion of power line, equipment, and load line.</p> <p>Follow OSHA 29CFR 1926.1400.</p> <p>Death or serious injury will result from approaching or contacting a power line.</p>	

70392813

General Rules:

For all work in proximity to power supply plants or overhead wires, the following general rules apply:

1. Caution must be exercised in the planning, instruction for, and execution of such work to prevent any risk or danger to persons, equipment or goods.
2. Any power supply plant, installation or wire must be considered live until the responsible power supply authority has provided a declaration that the opposite is true.
3. Any directions or guidelines from the responsible power supply authorities or public bodies must be strictly observed.

Any person or company directly responsible for the implementation of work in the proximity of overhead wires or electric power stations must make sure that all personnel involved in the execution of such work is familiar with any laws, rules or safety regulations, national as well as local, governing such work in the relevant country, territory or zone.

Not until the operator has checked the above may loader operation start.

1. Switch the change-over valve, if any, to "loader"
2. Engage the PTO at low revolutions. The engine revolution speed is regulated by means of the hand accelerator to ensure that the oil flow from the hydraulic pump corresponds to the recommended pump flow for the loader. When starting up in the cold, the oil should circulate for a few minutes before operation starts.
3. Apply the vehicle parking brake.
4. Starting up (When loader is equipped with optional RCL system):
 - a. Pull out the emergency stop button - remember both sides of the loader, if necessary.
 - b. Push the green button once, the "RUN" diode is lit and the safety system is activated.

Stabilizer function:

- c. Push the yellow button and the "FUNC" and "F5" diodes are lit. After 10 seconds the diodes are turned off, but the stabilizer function remains activated. Now the stabilizer function is activated and items 5 through 7 below must be carried out.

Loader function:

- d. Either: Activate one of the control levers of the loader's control valve
or: Push the yellow button twice; "FUNC" is lit and "F5" is turned off.

All loader functions are now activated - carry out item 8.

5. Release the stabilizer lock and extend the stabilizer beam completely, and **lock it again**. If the stability of the vehicle and the loader is based on the stabilizer legs being fully deployed. The loader should only be used when the stabilizers are fully deployed. The operator must make sure that the vehicle has sufficient stability in the area in front of the stabilizers (over the cab). The stabilizers should be lowered just enough to raise the truck chassis a little in its suspensions. The tires must still have full contact with the ground.

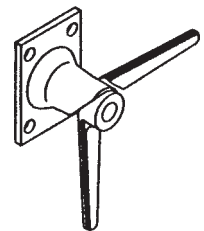

During loading of the truck, the operator must raise the stabilizer legs periodically to ensure that the truck and not the stabilizers carry the weight. The stabilizer legs are not designed to support this excessive load.

6. The vehicle must be positioned as close to horizontal as possible. Therefore, the driver should place the truck in as close a horizontal position as possible by means of the stabilizer legs before operating the loader.
7. If the ground is not firm enough to take up the pressure of the stabilizer legs, a plate, preferably steel, must be placed under the foot plates.

8.1. The unfolding of the loader takes place as described below:

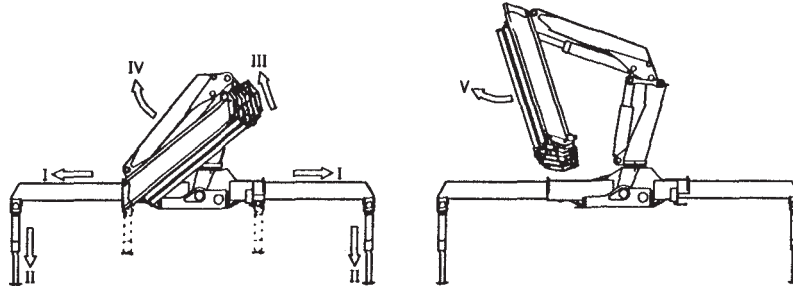

I. Extend stabilizer beams fully.

II. Lower the stabilizer legs according to items 5, 6 and 7 above.

III. The outer (jib) **must** be raised (the “outer/jib down” movement of the lever), so that the outer boom (jib) is released from the bracket.

IV. Raise the inner (main) boom and thereby release it from the bracket. Raise the inner (main) boom somewhat above horizontal, so that the outer boom can be moved freely downwards.

V. Raise the outer (jib) until it is free from the base.

NOTE

In the case of loaders equipped with stop bracket on the outer (jib), extend the extension booms a little until the stop bracket is released.

Stop bracket

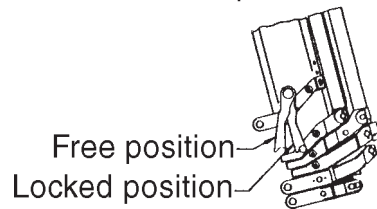

4.2 USING THE LOADER

After unfolding the loader, work may begin.

The lifting capacity of the loader is shown on the Capacity Chart on the loader and in this instruction manual. The capacity limits indicated must never be exceeded.

The loader is designed to lift loads vertically and therefore diagonal stresses must be avoided. Consequently the dragging of loads across the ground using the extension cylinders or the rotation system must be avoided. These functions should only be activated once the load is free of the ground.

When mounting a grapple, the total weight (grapple, rotator, and contents) must not exceed the lifting capacity of the loader at maximum reach. The grapple may be used to move soil only. It must not be used to excavate earth. Damage caused by improper operation of the loader will not be covered by the Warranty.

If the load is extended so far that the lifting capacity is exceeded, the load moment increasing movements will be stopped if the loader is equipped with the optional RCL system. See the RCL Safety System Instruction Manual. As regards non RCL equipped loaders, the inner (main) boom will slowly begin to sink in case of overloading. To stop this movement the load should be brought closer to the loader mast by means of the "extension retract" movement.

WARNING

Never stand under the booms when the loader is working.

NOTES

Position the truck as closely to the load as possible to lift the load on the shortest possible boom.

The rotation system should be operated with care, especially when the inner boom is at an acute angle to the outer boom.

The stabilizers may not be activated when the loader is working.

Never drive off with a suspended load.

4.3 AFTER OPERATION

The loader is folded up by reversing the procedure described in item 8, chapter 4.1 “Starting up”. If the boom is parked on the truck platform it must be properly secured to prevent the boom from swinging out during transport. Also, the operator must check that the total height does not exceed 157” (4000mm).

If the loader is equipped with swing-up stabilizer legs, they must also be secured in position before driving off.

Before the vehicle is started, the PTO must be disengaged; i.e. the pump must be turned off.

5. MAINTENANCE

Careful maintenance of the loader is the best way to ensure reliable loader operation.

At regular intervals, every day or every week, depending on frequency of loader application, you should check the following:

1. The oil level in tank and rotation system. Oil must be visible in the oil level glass of the tank when the loader is folded. If the loader is equipped with a planetary gear, check its oil level.
2. Any defects, damage or leaks should be repaired at an authorized service center as soon as discovered.
3. Loader to truck mounting hardware.
4. Slide blocks and bushings reduce friction and therefore they are naturally subject to wear. Slide blocks should be replaced when slack is detected in the boom system. Bushings should be replaced before the metal components physically touch each other.
5. Check all hoses for defects and kinks.
6. Check that hooks, straps and safety latches are in good working order.
7. Check all lock pins and bolts for wear.

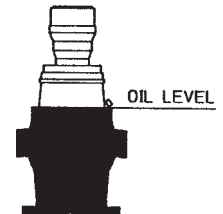

Service overhauls should be undertaken according to Section 13. In case of any warranty claims later, great importance will be attached to observance of these service overhauls.

5.1 LUBRICATION INTERVALS

Pinion of mast/Planetary gear (if any): after 50 hours of operation/1 month (whichever occurs first)

Base bearings: after 20 hours of operation/1 week (whichever occurs first)

Extension system/Slide blocks: after 50 hours of operation/1 month (whichever occurs first)

Guide rail on extension cylinders: after 50 hours of operation/1 month (whichever occurs first)

Pin connections/Bolts: after 50 hours of operation/1 month (whichever occurs first)

Stabilizer beams: as required

Control valves and rod connections (Oil spray): as required

The loader should be lubricated according to the lubrication chart below. Also see “Recommended Lubricants”.

5.2 LUBRICATION CHART

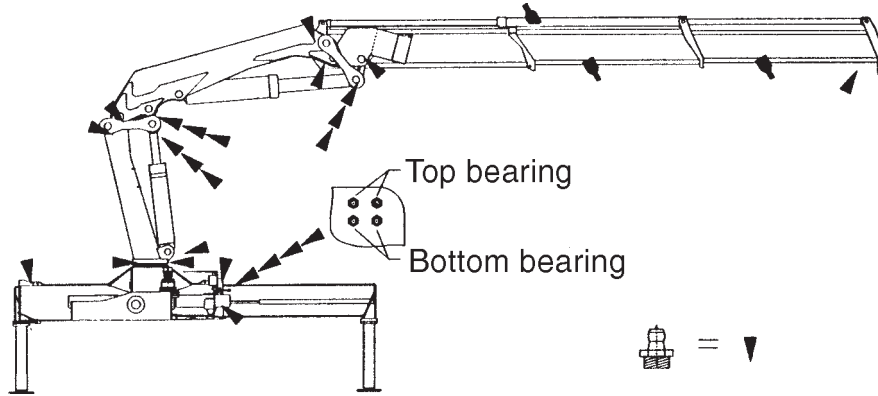

The rotation system should be activated and the loader swung from stop to stop several times within the entire rotation area at the same time as the bearings in the base are lubricated.

Hydraulic oil and lubrication grease are chosen according to the table in Section 13.

The telescopic extensions and planetary gear are lubricated with a special grease (Statoil Grease Way CaH or Castrol ALV).

CAUTION

If the loader is not folded after use, make sure that all cylinders are completely retracted at least once a day. The protective oil coating on the piston rods is thus maintained, preventing corrosion from occurring on the chromium surface.

6.0 OPTIONS

Various options are available with the loader:

- Fly-Jib
- Manual extensions
- Winch
- Pallet fork
- Remote control
- Radio remote control

Some loaders may, as standard, be equipped with options such as manual extensions, winch and Fly-Jib. For those loaders you will, apart from the descriptions below, also find technical data and pressure setting diagram, as well as lifting capacity diagrams for the Fly-Jib in this manual.

You should always consult your authorized dealer before mounting any optional equipment. This also applies to equipment already in your possession.

CAUTION

Welding onto or drilling into the structural components of the loader will automatically invalidate any liability on the part of IMT.

6.1 MANUAL EXTENSIONS

When working with manual extensions, please note:

The load limits indicated for manual extensions must never be exceeded.

Great care must be taken if the rotation system is to be activated during work with manual extensions.

If the loader is fitted with manual extensions or other options, the lifting capacity of the loader must be reduced by the weight of the options.

Always check that lock bolts are fitted correctly with a pin.

If the loader is fitted with several extensions and a certain lifting job requires the use of one extension only, use the extension with the largest box profile.

WARNING

Only pull out the manual extensions when the outer (jib) is as close to horizontal as possible. If the outer (jib) is pointed downwards when the lock is removed, the extensions will drop out at uncontrollable speed. This may damage the stop at the risk of resulting in personal injury.

The load must be extended from the stop; i.e. the extension lock pins must always remain in place.

7.0 LIFTING CAPACITY DIAGRAMS

7.1 CAPACITY CHARTS

From the factory, the loader is equipped with lifting capacity labels for the loader as well as for the options (manual extensions, Fly-Jib), if any. These labels must, just like any other labels on the loader, be intact and legible. If the label has been damaged or removed, you can order a new label from IMT. Use the part number used on the label or consult the parts manual, decal kit.

7.2 CAPACITY DIAGRAMS

As a supplement to the loader's lifting capacity labels, the following pages contain load and lifting capacities of the different K-versions in standard applications, i.e. special applications and customized labels and options are not taken into consideration. In these cases we refer to the supplementary documentation delivered and/or the lifting capacity labels on the loader.

WARNING

The lifting capacity limits indicated must never be exceeded.

CAPACITY CHART-15/113K3

IMT

MATERIAL HANDLING SYSTEMS

IOWA MOLD TOOLING CO., INC.
 BOX 189 • GARNER • IA • 50438 • 641-923-3711

**Model
 15/113K3**

- Working loads will be limited to those shown. Deduct the weight of load handling devices.
- Before lift is made, stability must be checked per SAE J765A.

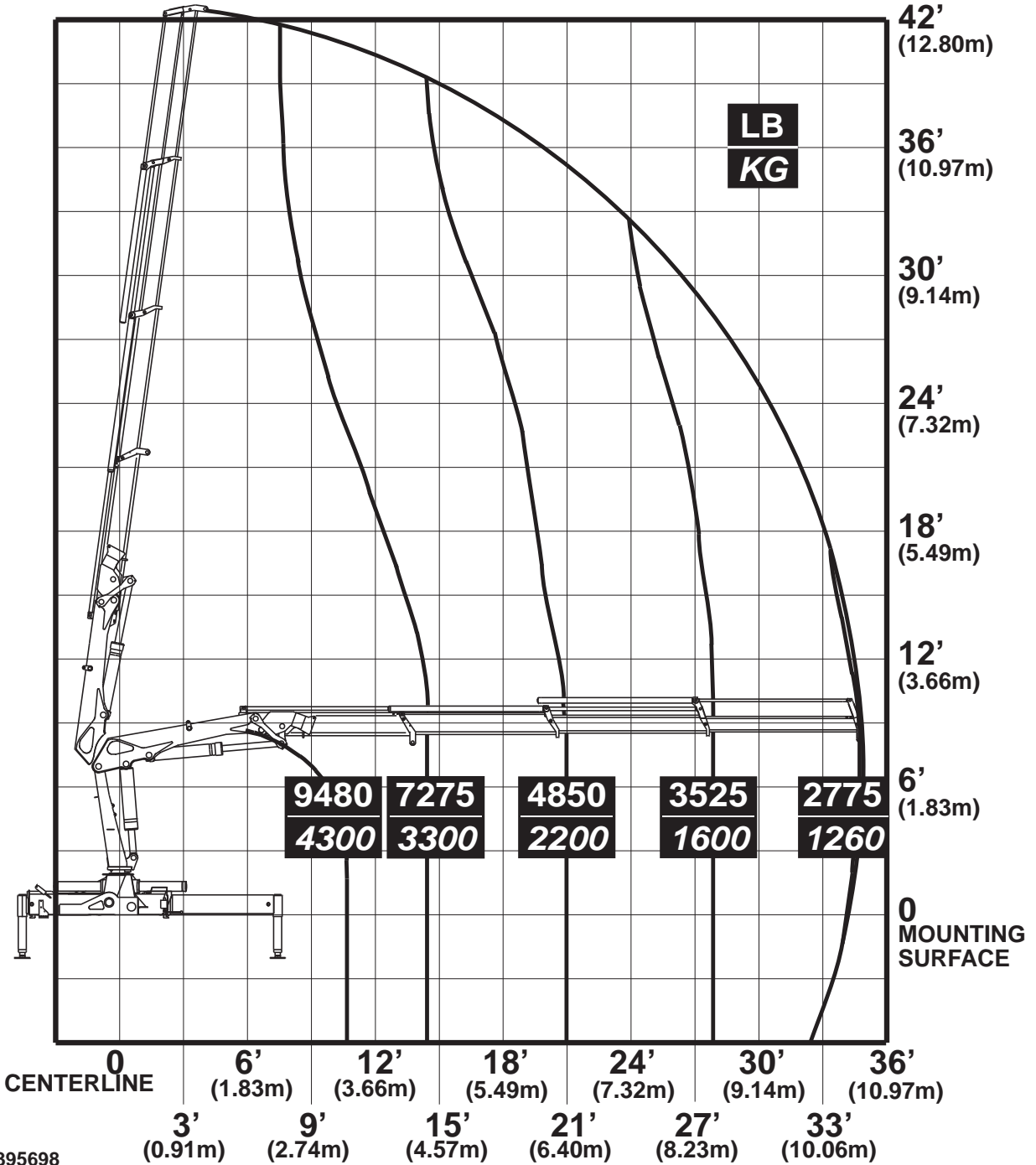

70395698

CAPACITY CHART-15/113K4

IMT

MATERIAL HANDLING SYSTEMS

IOWA MOLD TOOLING CO., INC.
 BOX 189 • GARNER • IA • 50438 • 641-923-3711

**Model
 15/113K4**

- Working loads will be limited to those shown. Deduct the weight of load handling devices.
- Before lift is made, stability must be checked per SAE J765A.

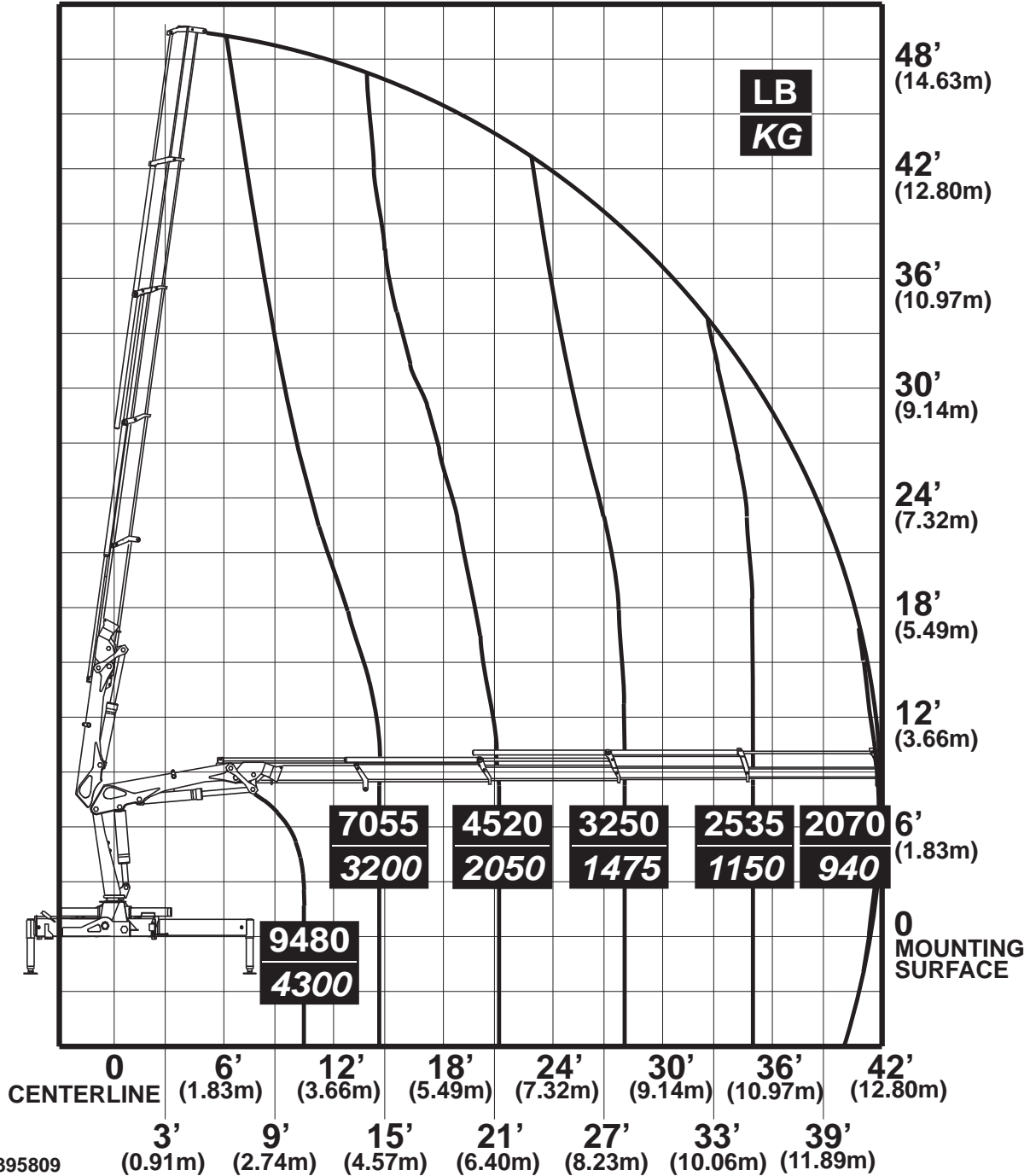

8.0 TECHNICAL DATA

The following pages contain tables with technical data on loader and Fly-Jib respectively, if a Fly-Jib is available as standard.

As standard the 15/113 K3 loader designation describes a loader with a 15 ton-meter/113000 foot-pound load moment and utilizes 3 hydraulic extensions.

REFERENCE DIMENSIONS

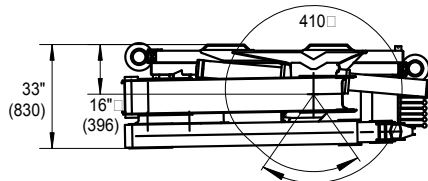
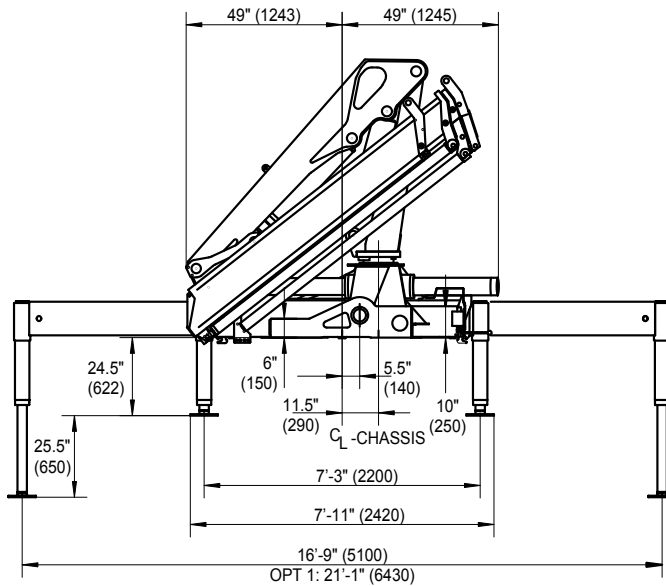
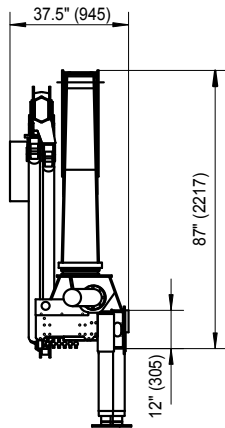
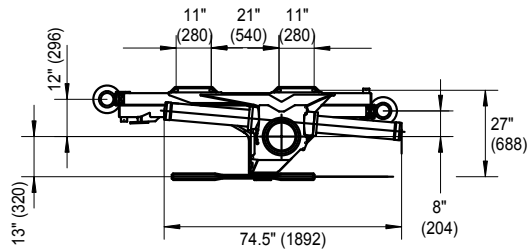
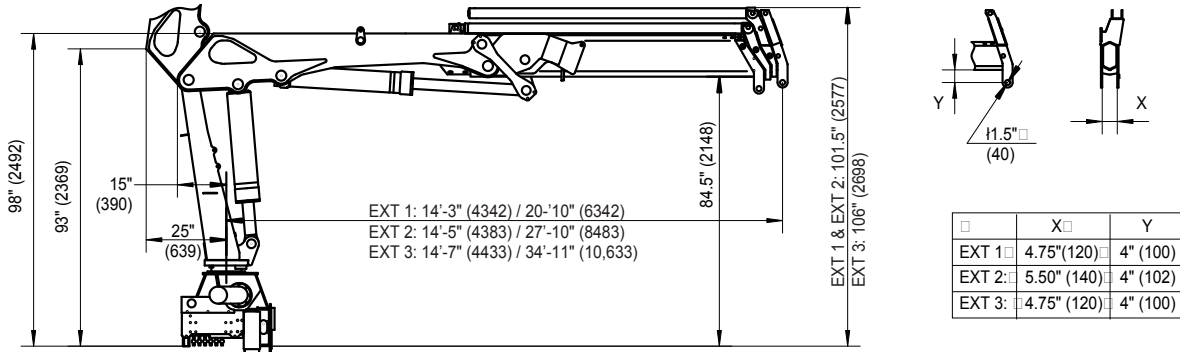

NOTE:
 ALL DIMENSIONS IN
 FEET & INCHES (mm).

TECHNICAL DATA (Domestic)

Performance	Unit	1 hyd ext	2 hyd ext	3 hyd ext	4 hyd ext
Crane Rating*	ft-lb	112,840	108,500	104,880	101,985
Max Horiz Reach	ft & in	20'-8"	27'-11"	34'-9"	41'-8"
Max Vert Reach	ft & in	28'-10"	35'-9"	42'-8"	49'-8"
Max. Capacity	lb	9480	9480	9480	9480
Max Cap@Max Reach	lb	5455	3825	2775	2070
Crane Weight**	lb	3440	3825	4155	4430
Hook Approach					
Vertical	ft & in	8'-2"	8'-2"	7'-11"	7'-11"
Horizontal	ft & in	2'-11"	2'-11"	3'-3"	3'-3"
Center of Gravity (Stored)					
Vertical	inches	31.0"	31.1"	31.9"	32.6"
Horiz (C/L Rot-Bridge)	inches	0.5"	1.6"	2.8"	3.6"
Stabilizer Pad Diameter	inches	9.0"	9.0"	9.0"	9.0"
Crane Storage Height	ft & in	7'-3"	7'-3"	7'-3"	7'-3"
Mounting Space***	inches	33.0"	33.0"	33.0"	33.0"
Rotation Torque	ft-lb	17360	17360	17360	17360
Rotation Angle	degrees	410	410	410	410
Optimum Pump Capacity	gpm (US)	13	13	13	13
System Pressure	psi	4060	4060	4060	4060
Oil Reservoir Capacity	gal	22.5	22.5	22.5	22.5
Stabilizer Extension Span					
Std-mnl out/hyd dn	ft & in	16'-9"	16'-9"	16'-9"	16'-9"
Weight	lb	550	550	550	550
Opt-hyd out/hyd dn	ft & in	21'-1"	21'-1"	21'-1"	21'-1"
Weight	lb	720	720	720	720

Minimum Chassis Specifications

Front Axle Rating (GAWR)	lb	12000	12000	12000	12000
Rear Axle Rating (GAWR)	lb	21000	21000	21000	21000
RBM	in-lb	1,550,000	1,550,000	1,550,000	1,550,000

Measures

Height above chassis					
when folded	in	87.3	87.3	87.3	87.3
Width when folded					
	in	98.4	98.4	98.4	98.4
Length, without extra valves					
	in	32.7	32.7	32.7	32.7
Length, with extra valves					
	in	37.2	37.2	37.2	37.2

* Maximum Crane Rating (ft-lbs) is defined as that rated load (lbs) which when multiplied by its respective distance (ft) from centerline of rotation gives the greatest ft-lb value.

** Crane weight excluding stabilizers.

*** Additional mounting space of 11" will be required to provide crane rotational clearance.

TECHNICAL DATA (Metric)

Performance	Unit	1 hyd ext	2 hyd ext	3 hyd ext	4 hyd ext
Crane Rating*	ton-m	15.6	15.0	14.5	14.1
Max Horiz Reach	m	6.3	8.5	10.6	12.7
Max Vert Reach	m	8.8	10.9	13.0	15.1
Max. Capacity	kg	4300	4300	4300	4300
Max Cap@Max Reach	kg	2475	1735	1260	940
Crane Weight	kg	1560	1735	1885	2010
Hook Approach					
Vertical	m	2.5	2.5	2.4	2.4
Horizontal	m	0.9	0.9	1.0	1.0
Center of Gravity (Stored)					
Vertical	mm	787	790	810	828
Horiz (C/L Rot-Bridge)	mm	10.0	40.0	70.0	90.0
Stabilizer Pad Diameter	mm	220	220	220	220
Crane Storage Height	m	2.2	2.2	2.2	2.2
Mounting Space	mm	830	830	830	830
Rotation Torque	ton-m	2.4	2.4	2.4	2.4
Rotation Angle	degrees	410	410	410	410
Optimum Pump Capacity	liters/min	49	49	49	49
System Pressure	bar	280	280	280	280
Oil Reservoir Capacity	liters	85	85	85	85
Stabilizer Extension Span					
Std-mnl out/hyd dn	m	5.1	5.1	5.1	5.1
Weight	kg	250	250	250	250
Opt-hyd out/hyd dn	m	6.4	6.4	6.4	6.4
Weight	kg	325	325	325	325

Minimum Chassis Specifications

Front Axle Rating (GAWR)	kg	5443	5443	5443	5443
Rear Axle Rating (GAWR)	kg	9525	9525	9525	9525
RBM	kg-m	17864	17864	17864	17864

Measures

Height above chassis when folded	mm	2217	2217	2217	2217
Width when folded	mm	2500	2500	2500	2500
Length, without extra valves	mm	830	830	830	830
Length, with extra valves	mm	945	945	945	945

* Maximum Crane Rating (ton-m) is defined as that rated load (ton) which when multiplied by its respective distance (m) from centerline of rotation gives the greatest ton-m value.

** Crane weight excluding stabilizers.

*** Additional mounting space of 280mm will be required to provide crane rotational clearance.

9. WORKING PRESSURE/PERFORMANCE

The working pressure should be set with a pressure gauge and the limits stated in the tables below must be kept.

The working pressure must be checked during the annual service overhaul and in the event of any major repairs.

The procedure for checking and setting of load-holding valves is described in Service Information. All adjustable valves must be resealed after pressure setting adjustment.

Please note that any warranty obligations on the part of IMT will be invalidated if the conditions stated in this manual are not complied with.

WORKING PRESSURE-15/113 (Domestic units)

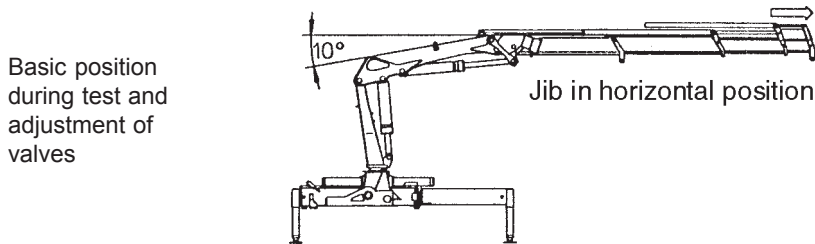

Working pressure on main-relief valve & port-relief valves

Function		Port	Unit	15/113
Main-relief valve			psi	4060
Rotation system	right	A-port		2540
	left	B-port		2540
Inner boom cylinder	down	A-port		1015
	up	B-port		P
Outer boom cylinder	up	A-port		4350
	down	B-port		2175
Extension cylinders	extend	A-port		P
	retract	B-port		P
Rotator		A-port		2900
		B-port		2900
Grapple		A-port		3625
		B-port		3625
Separate stabilizer valve				1815

Opening pressure on load holding valves

Inner boom cylinder				5075
Outer boom cylinder				4570
Extension cyl C1-V1	retract	B-port		6235
Extension cyl C2-V2	extend	A-port		3045
External relief valve				4495

Pressure setting for load moment limitation

LMB				3915
-----	--	--	--	------

Max. Pump performance

Pump performance		gpm		13.21
------------------	--	-----	--	-------

WORKING PRESSURE-15/113 (Metric units)

Basic position during test and adjustment of valves

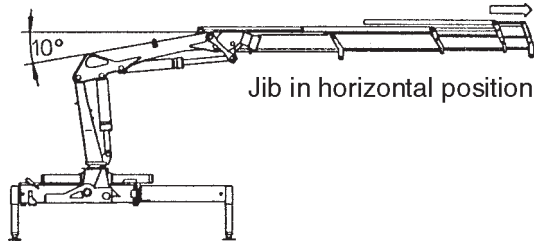

Working pressure on main-relief valve & port-relief valves

Function		Port	Unit	15/113
Main-relief valve			MPa	28.0
Rotation system	right	A-port		17.5
	left	B-port		17.5
Inner boom cylinder	down	A-port		7.0
	up	B-port		P
Outer boom cylinder	up	A-port		30.0
	down	B-port		15.0
Extension cylinders	extend	A-port		P
	retract	B-port		P
Rotator		A-port		20.0
		B-port		20.0
Grapple		A-port		25.0
		B-port		25.0
Separate stabilizer valve				12.5

Opening pressure on load holding valves

Inner boom cylinder				35.0
Outer boom cylinder				31.5
Extension cyl C1-V1	retract	B-port		43.0
Extension cyl C2-V2	extend	A-port		21.0
External relief valve				31.0

Pressure setting for load moment limitation

LMB				27.0
-----	--	--	--	------

Max. Pump performance

Pump performance			l/min	50.0
------------------	--	--	-------	------

1 MPa = 10 bar

10. HYDRAULIC SYSTEM

10.1 DESCRIPTION

The valve block of the loader is of the “stack” type, i.e., it is made up of a number of separate control valves. This ensures great flexibility and low maintenance costs.

A main relief valve is fitted in the inlet section of the valve block to ensure that the oil pressure in the pump line does not exceed the permissible limit. This valve is adjustable and must always remain sealed.

Port relief valves are mounted at the ports of the individual control valves to limit the pressure in the individual circuits. Normally the port relief valves will be pre-set and not adjustable.

The inner, outer, and extension cylinders are mounted with load holding valves with the following functions:

1. Protection of cylinders against excessive pressure.
2. Checking of the lowering speed of the boom.
3. Maintain the boom in position during operations where a fixed boom position is required.
4. To lock the boom and maintain the load in position in case of hose or pipe rupture.

The stabilizer cylinders are equipped with a piloted check valve that locks the cylinder in case of damage to the hydraulic system.

CAUTION

The main relief valve, the load holding valves, the dump valve and the external relief valve are sealed. If these seals are broken or removed the warranty will automatically be invalidated. Therefore, it is in your own interest to have the seals checked from time to time and to make sure that they are replaced by an authorized IMT service center should they be damaged.

Any modification or alteration to the hydraulic system must be in accordance to specific agreement with IMT and such alterations should always take place at an IMT service center.

10.2 HYDRAULIC DIAGRAMS

Hydraulic diagrams are a great help when troubleshooting and repairing the hydraulic system.

The following page contains the hydraulic diagram for the loader in standard application, as well as for options, if any.

There may be changes in design of the hydraulic system when applied to special and/or customized loaders. In these cases refer to the supplementary documentation.

STANDARD HYDRAULIC DIAGRAM

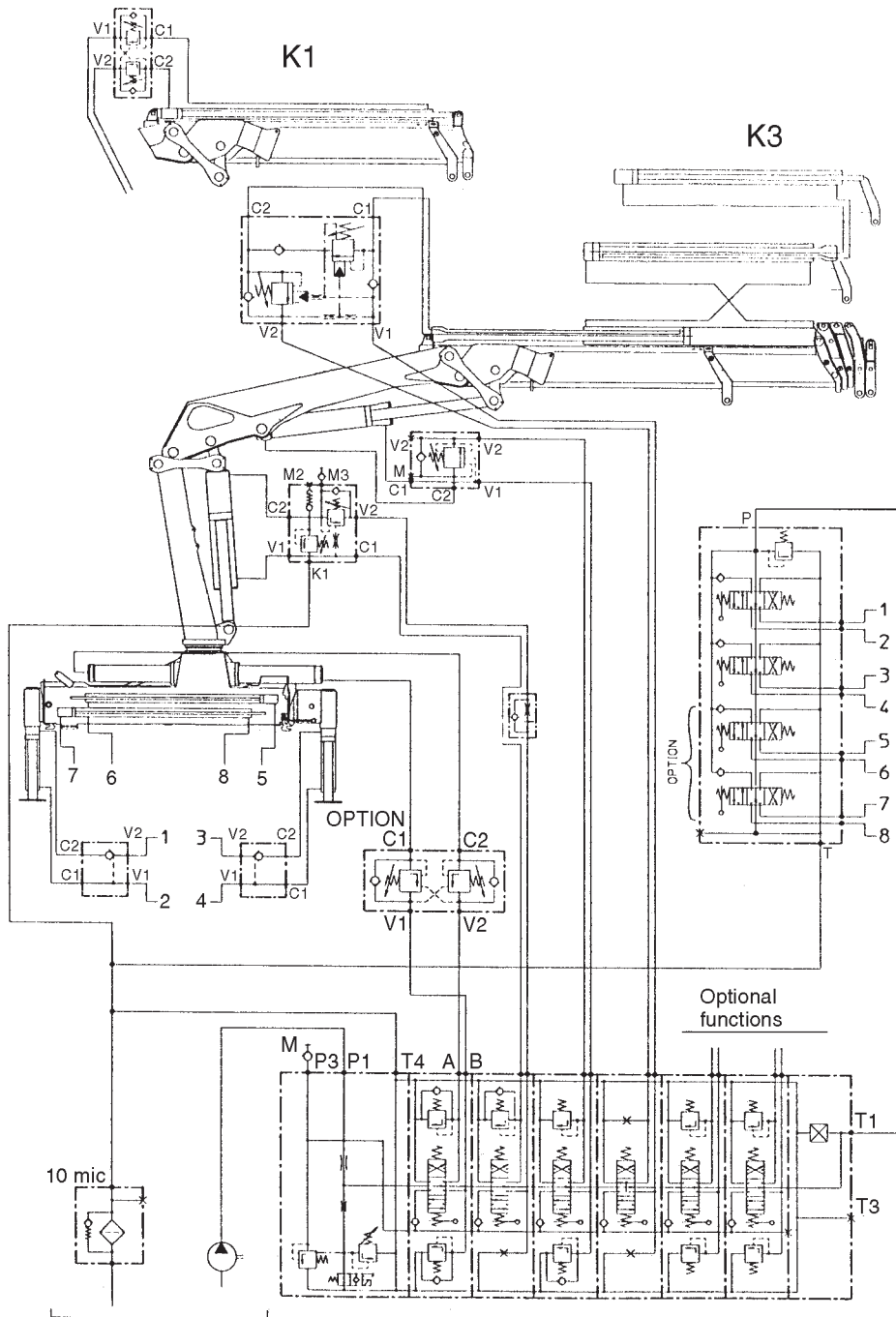

11. BLEEDING OF AIR

If air has entered the hydraulic system, the loader is bled as follows:

1. Raise and lower each stabilizer leg twice.
2. Extend and retract the inner boom cylinder twice.
3. Extend and retract the outer cylinder twice with the inner boom pointing downward, and twice with the inner boom pointed upward.
4. Extend and retract the extension cylinder twice with the outer boom pointed almost vertically upward, and twice with the outer boom pointed almost vertically downward.

12. REPAIR

If defects, damage or leaks are found, repair them immediately. Always have your repairs performed by an authorized IMT service center. Repairs to the hydraulic system must be made only at an authorized service center.

When ordering parts for your loader, please state:

- Loader model
- Loader serial number (found on serial number placard on loader)

13. SERVICE

13.1 FIRST SERVICE OVERHAUL

We recommend that the first service overhaul takes place at an authorized IMT service center after the first 20 hours of service or after one month of loader use at the latest. This service check is rather important since the loader will be properly run in after 20 hours of use.

The first service overhaul should include the following:

1. Change of return filter element and high pressure filter cartridge, if any.
2. The oil level in tank and rotation system. Oil must be visible between maximum and minimum lubrication on the oil level rod, when the loader is in the folded position. The oil level in the slewing system should also be visible in the inspection tube.
3. Overall lubrication according to the lubrication chart in this manual.
4. Leak check and tightening of fittings, if required.
5. Checking of working pressure and lead seals. The correct working pressures are stated in relevant Technical Information sheets.
6. Test of all functions under load.
7. Checking and, if required, tightening of mounting bolts and pin connections.
8. Checking of all lock bolts and pins.

13.2 ANNUAL SERVICE OVERHAUL

Once a year the loader should be given a main service overhaul at an authorized IMT service center. The loader should be thoroughly checked and special attention should be paid to the following items:

1. Change of hydraulic oil in tank and rotation system, if any.
2. Change of return filter element and high pressure filter cartridge.
3. Cleaning or replacement of air filter.
4. Checking of working pressure and valve lead seals.
5. Idling pressure check.
6. Test of all functions under load.
7. Checking of slide blocks and bearing bushings for wear and, if required, replacement of the same.
8. Check of hydraulic hoses.
9. Leak check and tightening of all connections.
10. Check of pump and transmission.
11. Check of loader base to chassis mounting hardware.
12. Checking of all bolt connections and tightening, if required.
13. Overall checking of loader structure for damage. Any damage found should be repaired immediately.
14. Checking of all bolts and lock plates.

13.3 RECOMMENDED HYDRAULIC OIL TYPES

Oil Brand	Oil Type	Low Temp Oil Type
BP	Bartran HV 32	Bartran HV 22
Castrol	Hyspin AWS 32	Hyspin AWH 32
ESSO	Nuto H 32	Univis N 22
Kuwait petroleum Q8	Harmony 32 AW	Hydraulic L 32
Mobil	DTE 13	DTE 11
Shell	Tellus S 32	Tellus T 32
Statoil	Hydra Way HM 32	Hydra Way HV 22
Texaco	Rando HD 32	Rando HDZ 32

13.4 RECOMMENDED LUBRICANTS

Grease Brand	Grease for Bearings
BP	Energrease L52
Castrol	LM Grease
ESSO	MP Grease I Beacon EP 2
Mobil	Mobilux EP 2 or Mobilgrease HP
Shell	Retinox MS
Statoil	Uni Way EP 2
Texaco	Multifak All Purpose EP 2

Grease containing molybdenum disulphide must not be used.

Grease Brand	Grease for Telescopic Extensions
Statoil	Grease Way CaH 92
Castrol	ALV

IOWA MOLD TOOLING CO., INC.

BOX 189, GARNER, IA 50438-0189

TEL: 641-923-3711

TECHNICAL SUPPORT FAX: 641-923-2424