

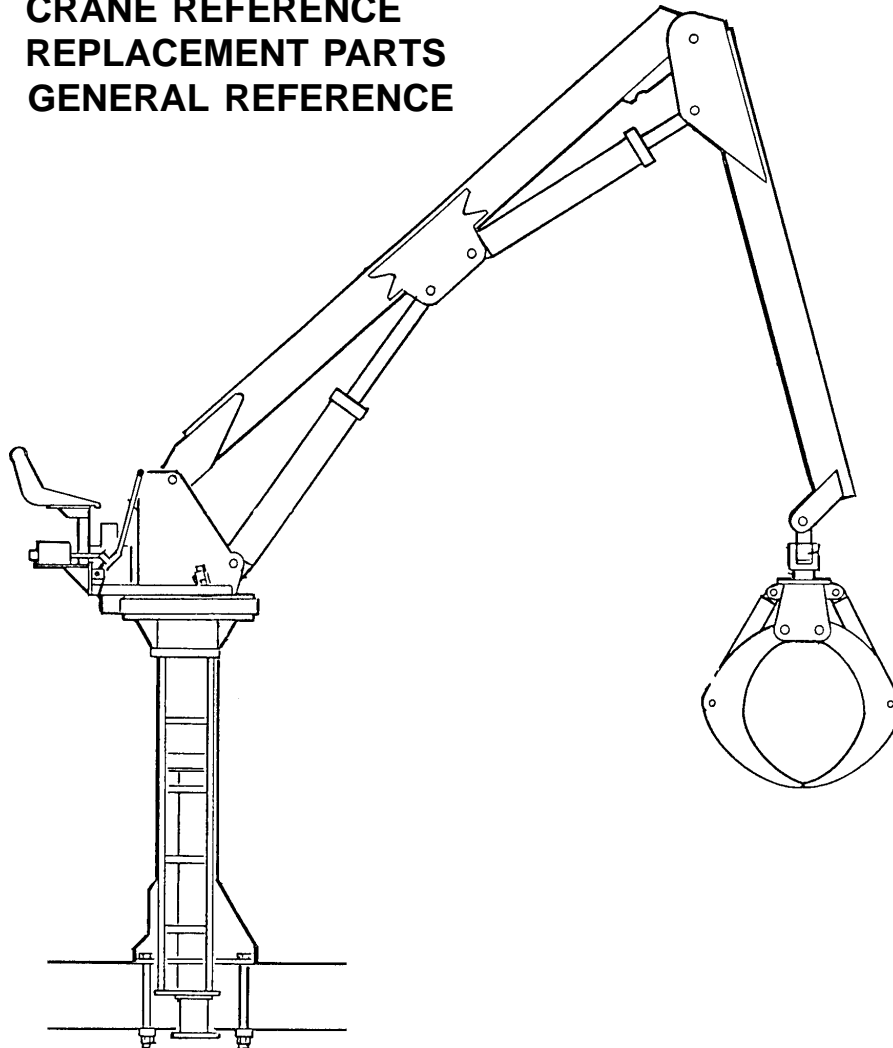

# *Model 1225R Loader*

## **Volume 2 - PARTS AND SPECIFICATIONS**

- Section 1    CRANE SPECIFICATIONS**
- Section 2    CRANE REFERENCE**
- Section 3    REPLACEMENT PARTS**
- Section 4    GENERAL REFERENCE**



**IOWA MOLD TOOLING CO., INC.**

BOX 189, GARNER, IA 50438-0189

TEL: 515-923-3711

TECHNICAL SUPPORT FAX: 515-923-2424

MANUAL PART NUMBER 99900924

## INTRODUCTION

This volume deals with information applicable to your particular crane. For operating, maintenance and repair instructions, refer to Volume 1, OPERATION, MAINTENANCE AND REPAIR.

We recommend that this volume be kept in a safe place in the office.

This manual is provided to assist you with ordering parts for your IMT crane. It also contains additional instructions regarding your particular installation.

It is the user's responsibility to maintain and operate this unit in a manner that will result in the safest working conditions possible.

Warranty of this unit will be void on any part of the unit subjected to misuse due to overloading, abuse, lack of maintenance and unauthorized modifications. No warranty - verbal, written or implied - other than the official, published IMT new machinery and equipment warranty will be valid with this unit.

In addition, it is also the user's responsibility to be aware of existing Federal, State and Local codes and regulations governing the safe use and maintenance of this unit. Three means are used throughout this manual to gain the attention of personnel. They are NOTE's, CAUTION's and WARNING's and are defined as follows:

### NOTE

A NOTE is used to either convey additional information or to provide further emphasis for a previous point.

### CAUTION

A CAUTION is used when there is the very strong possibility of damage to the equipment or premature equipment failure.

### WARNING

A WARNING is used when there is the potential for personal injury or death.

Treat this equipment with respect and service it regularly. These two things can add up to a safer working environment.

**Read and familiarize yourself with the  
IMT OPERATOR'S CRANE SAFETY MANUAL  
before operating or performing any maintenance  
on your crane.**

# SECTION 1. MODEL 1225R LOADER SPECIFICATIONS

<b>GENERAL SPECIFICATIONS .....</b>	<b>3</b>
<b>PERFORMANCE CHARACTERISTICS .....</b>	<b>3</b>
<b>CYLINDERS .....</b>	<b>3</b>
<b>POWER SOURCE.....</b>	<b>3</b>
<b>CYLINDER HOLDING VALVES .....</b>	<b>4</b>
<b>ROTATION SYSTEM .....</b>	<b>4</b>
<b>HYDRAULIC SYSTEM .....</b>	<b>4</b>
<b>OPERATOR'S STATION.....</b>	<b>4</b>
<b>MINIMUM CHASSIS SPECIFICATIONS .....</b>	<b>4</b>
<b>RECOMMENDED CHASSIS SPECIFICATIONS .....</b>	<b>4</b>
<b>OUTRIGGER DIMENSIONS .....</b>	<b>5</b>
<b>GEOMETRIC CONFIGURATION-WITH EXTENSION BOOM.....</b>	<b>5</b>
<b>CAPACITY CHART .....</b>	<b>6</b>





## 1225R LOADER SPECIFICATIONS

### GENERAL SPECIFICATIONS

<b>LOADER RATING</b>	80,000 ft-lbs	(11.06 ton-m)
<b>HORIZONTAL REACH</b> (from centerline of rotation)	25'-0"	(7.62m)
<b>* LIFTING HEIGHT</b> (from mounting surface)	33'-8"	(10.26m)
<b>LOADER WEIGHT</b> (less grapple)	6350 lbs	(2880 kg)
<b>** OUTRIGGER SPAN AT GROUND LEVEL MAXIMUM</b>	9'-2" 10'-5"	(2.79m) (2.64m)
<b>OUTRIGGER PADS</b>	12" X 21"	(30.5x53.3cm)
<b>LOADER STORAGE HEIGHT</b>	13'-0"	(3.96m)
<b>MOUNTING SPACE REQUIRED</b>	28"	(71.1cm)
<b>OPTIMUM PUMP CAPACITY</b> (tandem)	16/16 gpm	(60.5/60.5 lpm)
<b>SYSTEM OPERATING PRESSURE</b>	2200 psi	(152 bar)
<b>OIL RESERVOIR CAPACITY</b>	49 Gallons	(185 liters)
<b>ROTATIONAL TORQUE</b>	11,150 ft-lbs	(1.54 ton-m)
<b>HORIZ. HOOK APPROACH</b> (from centerline of rotation)	3'-8"	(1.12m)
<b>* VERT. HOOK APPROACH</b> (from mounting surface)	8'-1"	(2.46M)

\* Add frame height of 40" (1.02m) for dimension from ground level.

\*\* Using 40" (1.02m) frame height.

### PERFORMANCE CHARACTERISTICS

<b>ROTATION:</b>	Continuous	
<b>INNER BOOM ARTICULATION:</b>	-22° to +77.5° (-.38 to +1.35 Rad.)	16 seconds
<b>OUTER BOOM ARTICULATION:</b>	156° (2.72 Rad.)	16 seconds
<b>EXTENSION:</b>	36" (91.4cm)	3 seconds
<b>OUTRIGGER:</b>	36.5" (92.7cm)	6 seconds

### CYLINDERS

	<b>BORE</b>	<b>ROD</b>	<b>STROKE</b>
<b>INNER BOOM CYLINDER</b>	6" (15.2cm)	3" (7.6cm)	34" (86.4cm)
<b>OUTER BOOM CYLINDER</b>	6" (15.2cm)	3" (7.6cm)	34" (86.4cm)
<b>EXTENSION BOOM CYLINDER</b>	2.5" (6.4cm)	1.5" (3.8cm)	36" (91.4cm)
<b>OUTRIGGER CYLINDERS</b>	3.5" (8.9cm)	2" (5.1cm)	36.5" (92.7cm)

### POWER SOURCE

Integral-mounted tandem hydraulic pump and PTO application. Other standard power sources may be utilized for non-truck mounted applications.

## CYLINDER HOLDING VALVES

The holding sides of all cylinders are equipped with integral-mounted holding or counter-balance valves to prevent sudden cylinder collapse in the case of hose or other hydraulic system failure. The outrigger cylinders have positive, pilot-operated holding valves that open only on command.

The inner, outer and extension boom cylinders have pilot operated counter-balance valves. The counter-balance valve serves several functions. First, it is a holding valve. Secondly, it is so constructed that it will control the lowering function and allow that motion to be feathered while under load. Finally, if a hose breaks, the only oil loss will be that in the hose.

## ROTATION SYSTEM

Rotation of the loader is accomplished through a turntable bearing, powered by a high torque hydraulic motor through a heavy-duty gear box equipped with a heat treated pinion. The pinion runs on the external gear teeth of the turntable bearing to accomplish the rotation function. Standard rotation is 360° (6.28 Rad.) continuous. A spring applied, hydraulic release rotation brake provides positive stopping and starting of the rotation process.

## HYDRAULIC SYSTEM

The hydraulic system is an open centered, full pressure system, requiring 16/16 GPM (60.5/60.5 liters/minute) optimum oil flow, at 2200 PSI (152 bar). Eight-spool, stack-type control valve with integral manual operational handles located at the top (mast-mounted) control station. The system includes a hydraulic oil reservoir with suction line strainer and air breather, return line filters, 8-section control valve, and all hoses and fittings.

## OPERATOR'S STATION

Loader controls are located on a rotating platform attached to the side of the mast of the standard unit. This platform is accessible from both sides of the loader by the standard dual ladders.

## MINIMUM CHASSIS SPECIFICATIONS

<b>BODY STYLE</b>	Conventional Cab	Conventional Cab
<b>WHEELBASE</b>	213"	541cm
<b>CAB-TO-AXLE</b>	144"	366cm
<b>FRAME SECTION MODULUS</b>	22 cubic inches	360cc
<b>RBM</b>	1,100,000 in-lbs	12,674 kg-m
<b>FRONT AXLE RATING</b>	9000 lbs	4083 kg
<b>REAR AXLE RATING</b>	18000 lbs	8165 kg
<b>TRANSMISSION</b>	5-speed manual	5-speed manual

## RECOMMENDED CHASSIS SPECIFICATIONS

<b>BODY STYLE</b>	Conventional Cab	Conventional Cab
<b>WHEELBASE</b>	234"	595cm
<b>CAB-TO-AXLE</b>	156"	396cm
<b>FRAME SECTION MODULUS</b>	22 cubic inches	360cc
<b>RBM</b>	1,100,000 in-lbs	12,674 kg-m
<b>FRONT AXLE RATING</b>	12000 lbs	5443 kg
<b>REAR AXLE RATING</b>	20000 lbs	9072 kg
<b>TRANSMISSION</b>	5-speed manual	5-speed manual

NOTE: The addition of counter-weight/sub-frame/auxiliary outriggers to the chassis may be required to achieve and maintain full 360° stability for certain applications.

In addition to these specifications, heavy-duty electrical and cooling systems and dual rear wheels are required. It is recommended that the vehicle be equipped with an electric engine tachometer, auxiliary brake lock, and power steering.

*IMT reserves the right to change specifications and design without notice.*

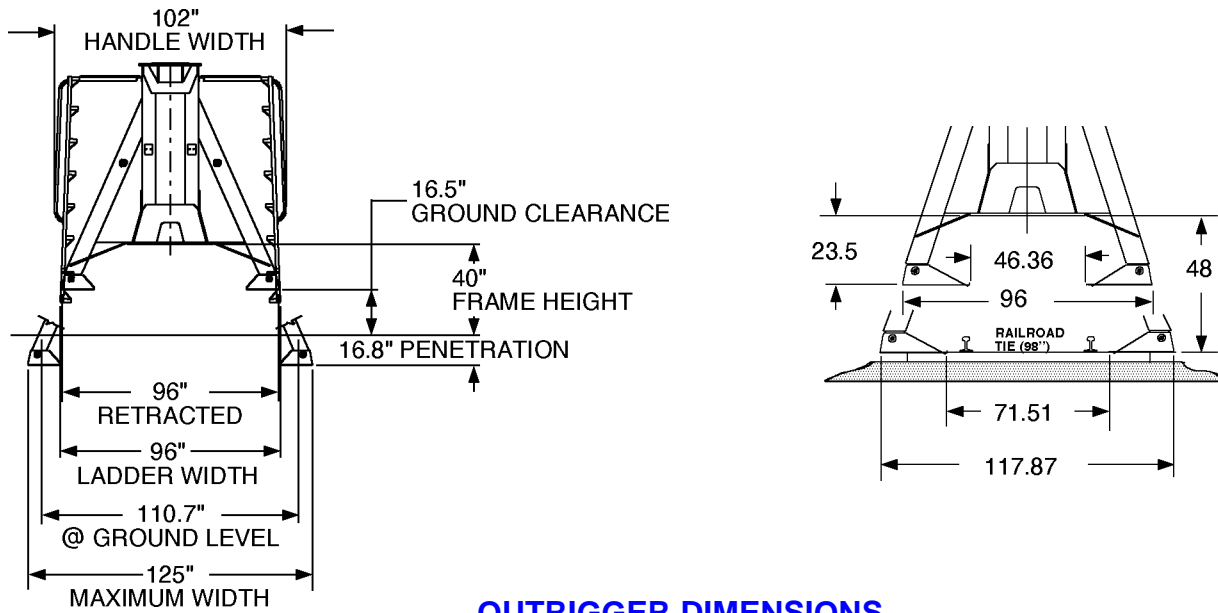

**OUTRIGGER DIMENSIONS**

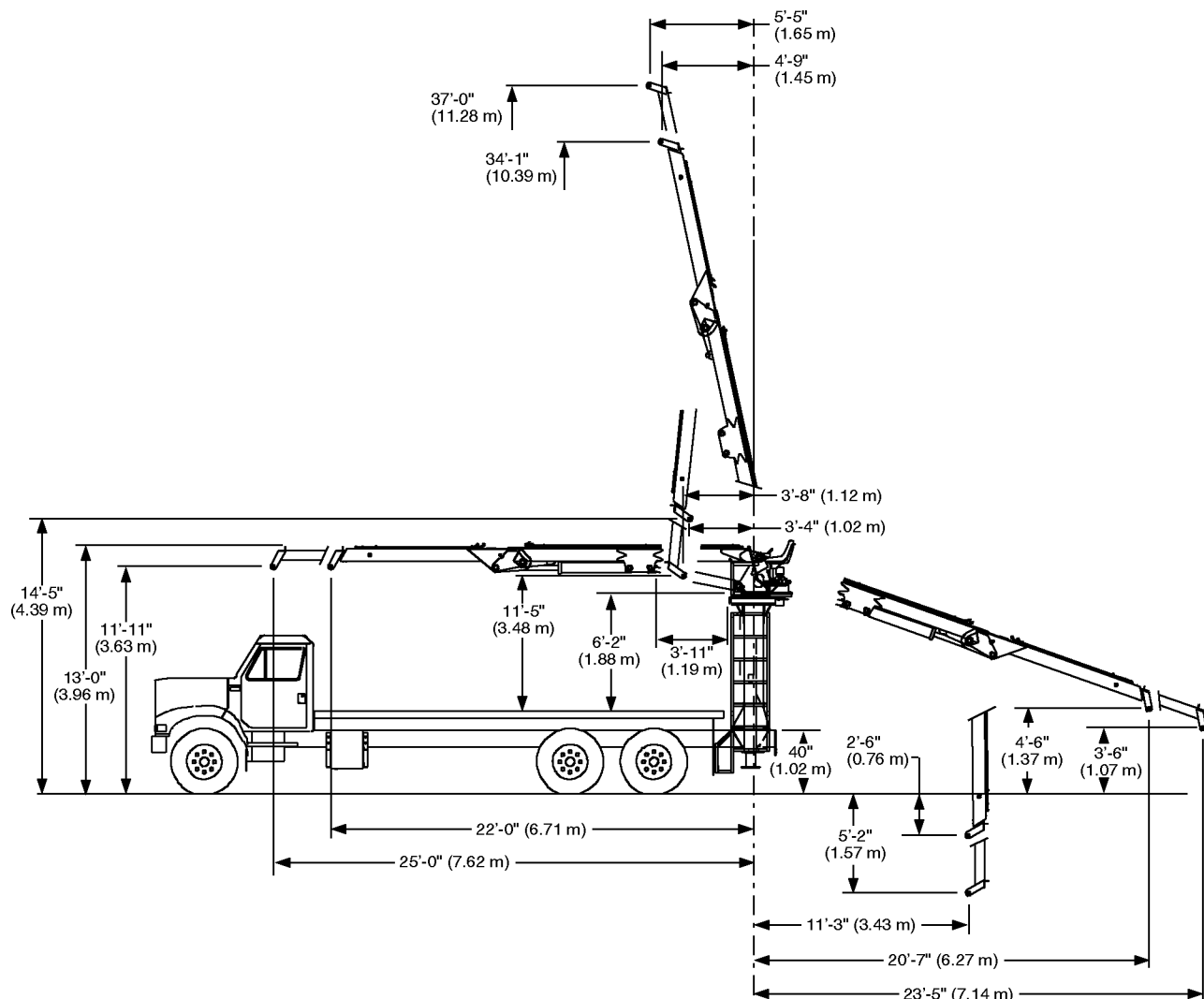

**GEOMETRIC CONFIGURATION-WITH EXTENSION BOOM**

### CAPACITY CHART

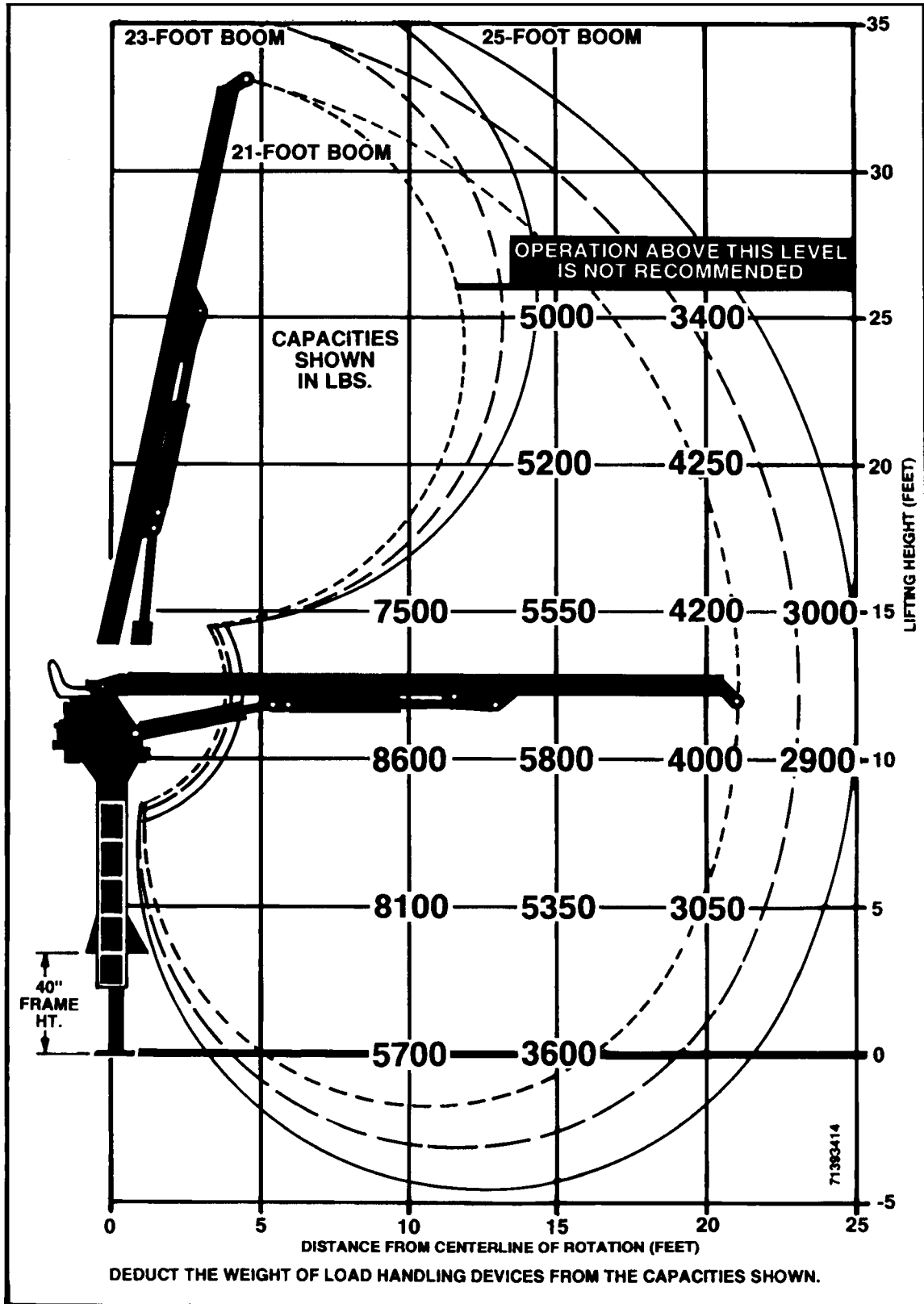



## **SECTION 2. 1225R LOADER REFERENCE**

<b>MAJOR CRANE ASSEMBLIES .....</b>	<b>3</b>
<b>GREASE ZERK LOCATIONS &amp; LUBRICANT REQUIREMENTS .....</b>	<b>4</b>
<b>RECOMMENDED SPARE PARTS LIST .....</b>	<b>5</b>
<b>JOYSTICK CONTROLS .....</b>	<b>7</b>
<b>PRECAUTIONS .....</b>	<b>8</b>



# MAJOR CRANE ASSEMBLIES

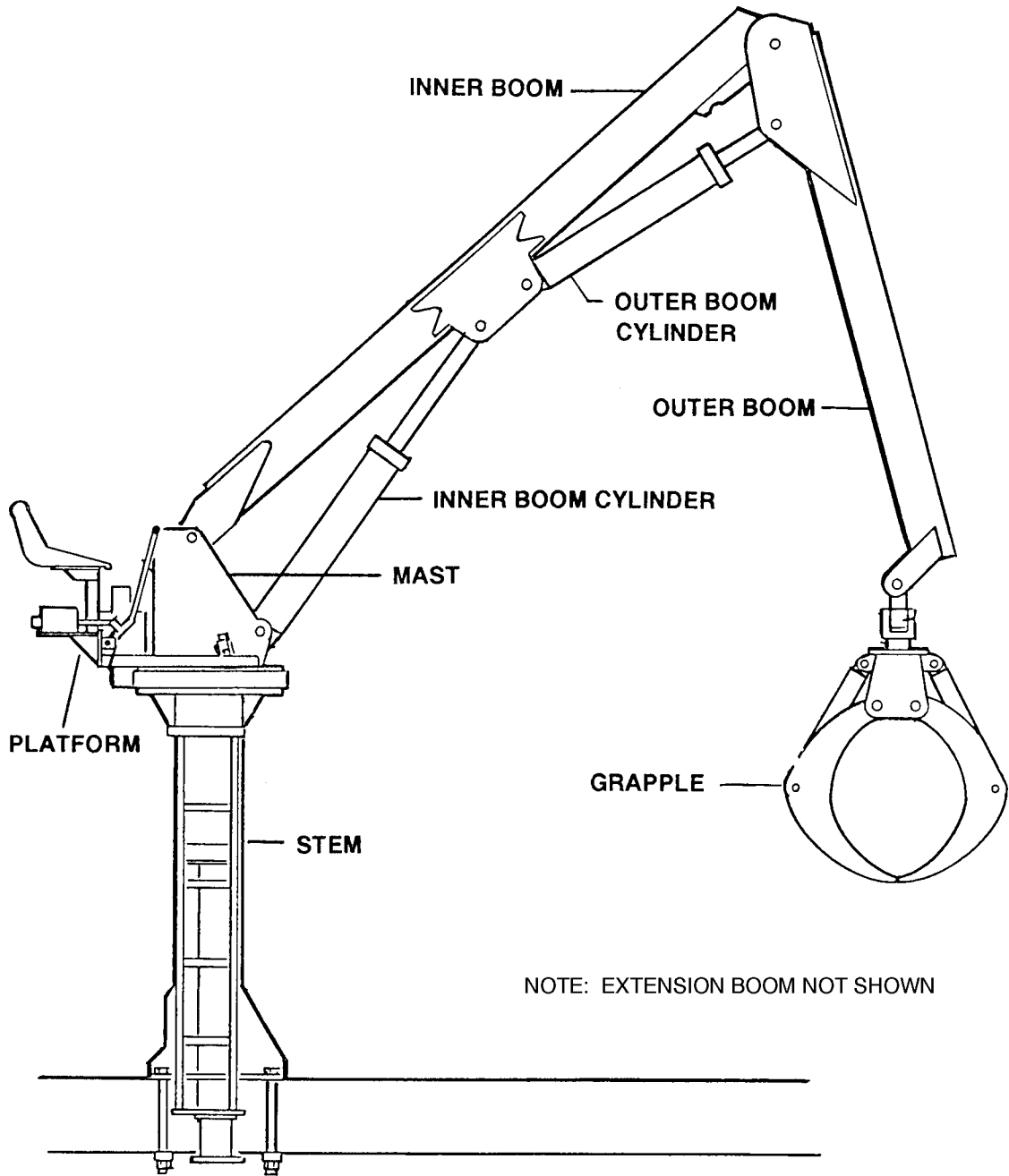

# GREASE ZERK LOCATIONS & LUBRICANT REQUIREMENTS

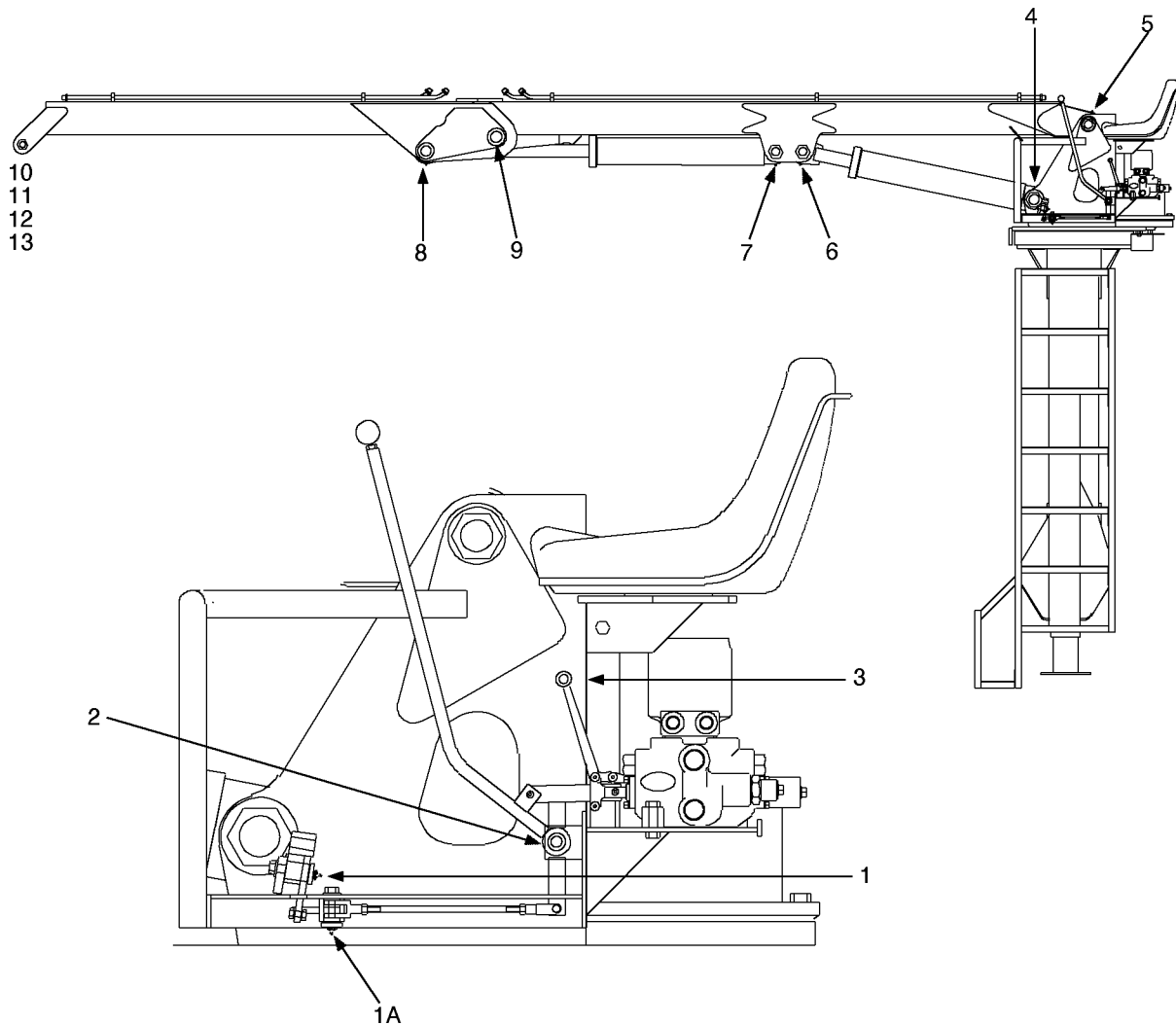

ITEM	LOCATION DESCRIPTION	LUBRICANT	FREQUENCY
1.	FOOT PEDAL	SHELL ALVANIA 2EP  OR  SHELL RETINAX "A"	WEEKLY
1A.	LINKAGE		
2.	LEVER STYLE CONTROL HANDLES		
3.	TURNTABLE/BEARING GREASE EXTENSION *ROTATE CRANE WHILE GREASING		
4.	INNER CYLINDER BASE		
5.	MAST/INNER BOOM HINGE PIN		
6.	INNER CYLINDER ROD		
7.	OUTER CYLINDER BASE		
8.	OUTER CYLINDER ROD		
9.	INNER BOOM/OUTER BOOM HINGE PIN		
10.	GRAPPLE SWIVEL		
11.	GRAPPLE CYLINDER ROD & BASE		
12.	GRAPPLE HEAD		
13.	GRAPPLE JAW HINGES		

NOTE: All application points must be greased weekly under normal work loads and moderate weather conditions. Under severe operating conditions, lubrication should be performed more frequently. See Volume 1; Operation, Maintenance and Repair for additional lubrication requirements.

**RECOMMENDED SPARE PARTS LIST****1 YEAR SUPPLY****1225R LOADER****FOR MANUAL: 99900924**

This spare parts list does not necessarily indicate that the items can be expected to fail in the course of a year. It is intended to provide the user with a stock of parts sufficient to keep the unit operating with the minimal down-time waiting for parts. There may be parts failures not covered by this list. Parts not listed are considered as not being Critical or Normal Wear items during the first year of operations and you need to contact the distributor or manufacturer for availability.

<b>ASSEMBLY DESIGNATION</b>	<b>ITEM NO.</b>	<b>PART NO.</b>	<b>DESCRIPTION</b>	<b>QTY</b>	<b>CODE</b>	<b>SHELF LIFE (MO)</b>	<b>ORDER QTY</b>
<b>3B025920.01.19971110</b>			<b>OUTRIGGER CYLINDER</b>				
	5	9B025920	SEAL KIT	2	W		
<b>41713774.01.19970404</b>			<b>MAST ASM-CONTINUOUS ROTATION</b>				
	1	71056440	GEAR BEARING	1	W		
	5	73051473	MOTOR	1	W		
	7	70731795	C'BAL VALVE	1	C		
	9	71056439	PINION GEAR	1	W		
<b>3C274960.01.19961212</b>			<b>INNER/OUTER BOOM CYLINDER</b>				
	4	70143838	BALL BUSHING	4	W		
	7	9B019920	SEAL KIT	2	W		
	18	73054242	C'BAL VALVE	4	C		
<b>41713759.01.19980203</b>			<b>OUTER/EXTENSION BOOM ASSEMBLY</b>				
	12	60030219	SLIDE BUSHING	1	W		
	16	60030220	SLIDE BUSHING	1	W		
<b>3B275960.01.19961212</b>			<b>EXTENSION BOOM CYLINDER</b>				
	6	9C156920	SEAL KIT	1	W		
	17	73054242	C'BAL VALVE 25GPM	2	C		
<b>41712420.01.19970716</b>			<b>CONTROL KIT - 4 WAY</b>				
	28	70024339	BUSHING	12	W		
<b>91713762.01.19980106</b>			<b>HYDRAULIC KIT 8-FUNCTION</b>				
	27	73054783	VELOCITY FUSE	2	W		
	29	73054795	HOLDING VALVE	2	W		
<b>93712607.01.19970829</b>			<b>INSTALLATION KIT - FRONT MOUNT</b>				
	5	70732791	SCREEN 100 MESH	3	W		
	7	73052014	RETURN FILTER ELEMENT	3	P		

0001225R:99900924: 19961212

2-6  
(BLANK)

## JOYSTICK CONTROLS

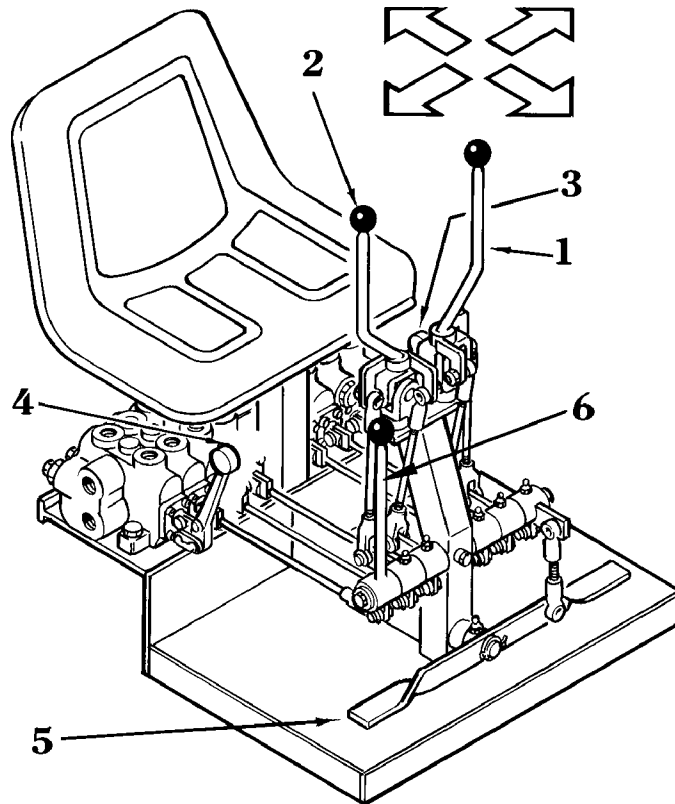

### CAUTION

BEFORE OPERATING THE LOADER, THE OPERATOR MUST FAMILIARIZE HIMSELF WITH ALL CONTROLS.

1. LEFT JOY-STICK    PULL BACK TO RAISE INNER BOOM  
PUSH FORWARD TO LOWER INNER BOOM  
PUSH LEFT TO OPEN GRAPPLE  
PUSH RIGHT TO CLOSE GRAPPLE
2. RIGHT JOY-STICK    PULL BACK TO RAISE OUTER BOOM  
PUSH FORWARD TO LOWER OUTER BOOM  
PUSH LEFT TO ROTATE GRAPPLE COUNTERCLOCKWISE  
PUSH RIGHT TO ROTATE GRAPPLE CLOCKWISE
3. LEFT LEVER        PUSH DOWN TO LOWER LEFT OUTRIGGER  
PULL UP TO RAISE LEFT OUTRIGGER
4. RIGHT LEVER        PUSH DOWN TO LOWER RIGHT OUTRIGGER  
PULL UP TO RAISE RIGHT OUTRIGGER
5. FOOT PEDAL        PUSH DOWN WITH LEFT FOOT TO SWING LEFT  
PUSH DOWN WITH RIGHT FOOT TO SWING RIGHT
6. RIGHT FWD LEVER    PUSH FORWARD TO EXTEND EXTENSION BOOM  
PULL BACK TO RETRACT EXTENSION BOOM

## PRECAUTIONS

### OPERATION PRECAUTIONS

1. Read and Understand the IMT Crane Safety Manual.
2. Beware of overhead electrical lines.
3. Apply truck brakes and block the wheels when operating.
4. Extend both outriggers. Use wood blocking on slippery surfaces. Soft or unstable footing can pose hazards. The loader should be operated on as level a plane as possible.
5. Operate the loader slowly at first, especially when swinging the booms. Plan each movement in advance, allowing time to slow down the swing before reversing direction. Use a “feathering” or “inching” technique to give a smooth working cycle. This is accomplished by moving the controls slowly into a partial open position. As the operator becomes more experienced he can move the controls into the full open position. Avoid quick, jerking movements.
6. Always lift your load so you have maximum stability by knuckling in simultaneously while lifting up.
7. During operations, periodically check outriggers for adequate loader stability.
8. Do not pick up more material than the grapple attachment rating recommends.
9. Never allow riders on the loader.
10. Never allow people to be under or near the load or raised boom.
11. Never move the truck while the operator is on the loader.
12. Never leave a “live” load unattended. Always disengage the PTO.
13. Always lower the grapple to the ground or truck bed before leaving the operator’s platform during and after loading.

14. Always fully retract the outriggers before moving.

### MAINTENANCE PRECAUTIONS

#### WARNING

Be alert to unusual sounds and vibrations. The cyclic nature of the loading on the mounting bolts of the rotation bearing gives rise to the possibility of their working loose or to inelastic deformation of the threads and other stressed surfaces. Bolts should be checked periodically. Retighten to 266-294 ft-lbs (maximum) torque on the 3/4-10 grade 8 socket head cap screws.

1. **HYDRAULIC SYSTEM** - The most important factor in the operation and maintenance of the hydraulic system is cleanliness. This begins with flushing of the hydraulic system whenever a considerable amount of maintenance work has been performed that might introduce dirt, metal chips or any other foreign material into the system.

When maintenance is performed on any hydraulic component, the parts should be cleaned thoroughly and lubricated with clean hydraulic oil before assembly. This is done to clean off any dirt which might be sticking to the part and also to provide a layer of lubricant to avoid metal to metal contact when the equipment is placed into operation.

2. **WELDING** - When performing electric welding on the loader, attach the ground to the assembly being welded. If the welding arc is grounded through any of the bearings which connect the assemblies, the bearings are likely to become damaged as a result of arcing.
3. **GEAR REDUCTION BOX** - Oil should be changed after the first 50 hours of use and at 500 hour intervals thereafter. Unit requires 4.5 pints of EP 80/90 gear oil. Output shaft bearings have grease fittings which should be greased sparingly every 50 hours of operation.
4. **GENERAL** - It is recommended that all mechanical parts and hydraulic components be checked regularly to avoid the possibility of injury or downtime as a result of loose bolts and pins, damaged hydraulic lines, or partial failure of any part.



## **SECTION 3. REPLACEMENT PARTS 1225R LOADER**

<b>PARTS INFORMATION .....</b>	<b>3</b>
<b>STEM ASM (41713739) .....</b>	<b>4</b>
<b>OUTRIGGER CYLINDER (3B025920) .....</b>	<b>5</b>
<b>MAST ASM-CONTINUOUS ROT'N (41713774-1) .....</b>	<b>6</b>
<b>MAST ASM-CONTINUOUS ROT'N (41713774-2) .....</b>	<b>7</b>
<b>ROTATION BRAKE (71056465) .....</b>	<b>8</b>
<b>INNER BOOM ASM (41713758) .....</b>	<b>9</b>
<b>INNER/OUTER BOOM CYLINDER (3C274960) .....</b>	<b>10</b>
<b>OUTER/EXTENSION BOOM ASM (41713759) .....</b>	<b>11</b>
<b>EXTENSION BOOM CYLINDER (3B275960) .....</b>	<b>12</b>
<b>VALVEBANK ASM 8-SECT (51713856) .....</b>	<b>13</b>
<b>CONTROL KIT-4 WAY (41712420-1) .....</b>	<b>14</b>
<b>CONTROL KIT-4 WAY (41712420-2) .....</b>	<b>15</b>
<b>HYDRAULIC KIT-8F (91713762-1) .....</b>	<b>16</b>
<b>HYDRAULIC KIT-8F (91713762-2) .....</b>	<b>17</b>
<b>HYDRAULIC KIT-8F (91713762-3) .....</b>	<b>18</b>
<b>HYDRAULIC KIT-8F (91713762-4) .....</b>	<b>19</b>
<b>INSTALLATION KIT-FRONT MOUNT (93712607) .....</b>	<b>20</b>
<b>DECAL KIT (95712423) .....</b>	<b>21</b>
<b>GRAPPLE MOUNTING KIT-NON DAMPENED-S&amp;L (51711384).....</b>	<b>22</b>
<b>GRAPPLE MOUNTING KIT-DAMPENED-S&amp;L (51712053) .....</b>	<b>23</b>
<b>2 GRAPPLE MOUNTING KIT-S&amp;L (51712163).....</b>	<b>24</b>

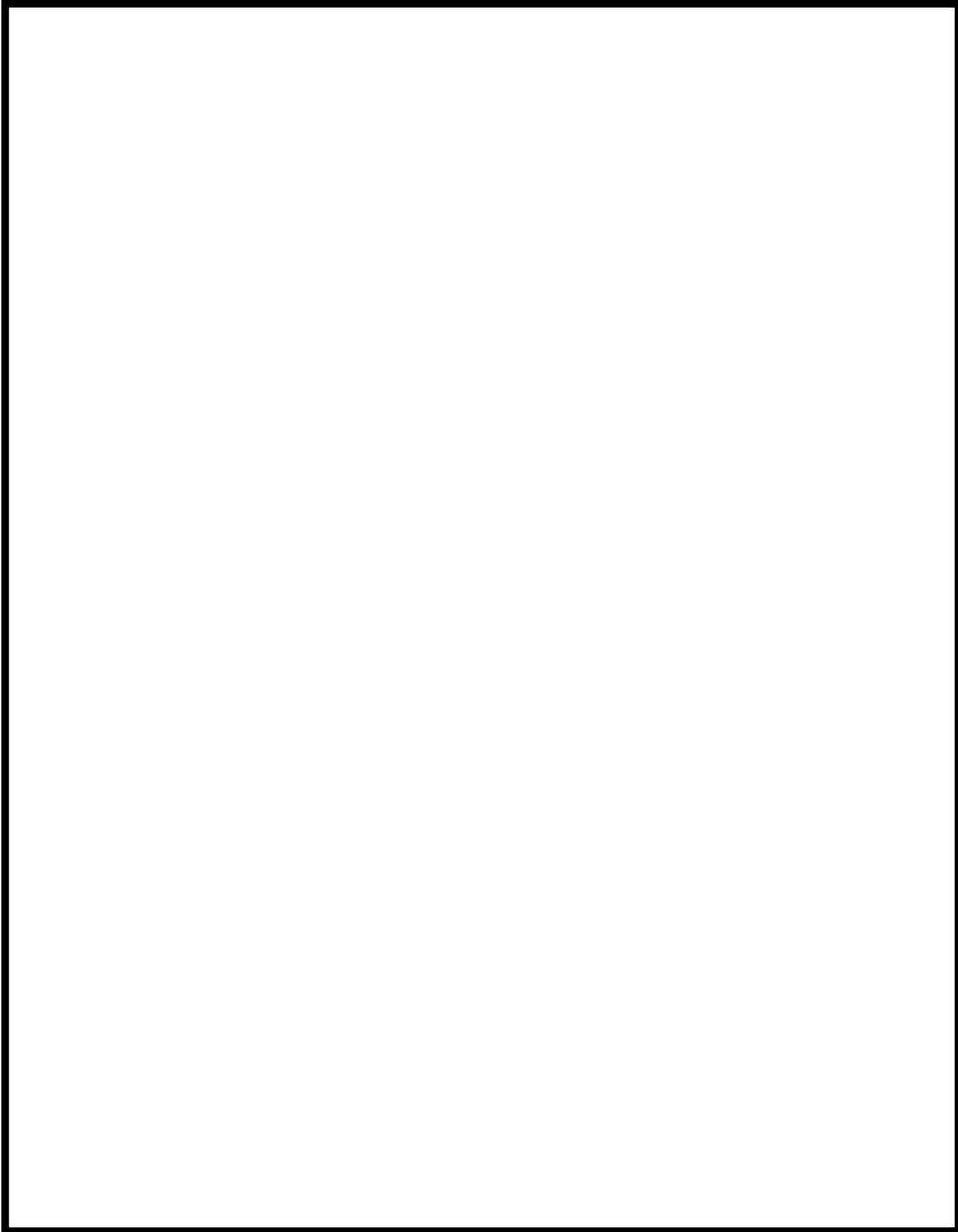

## PARTS INFORMATION

### GENERAL

This section contains the exploded parts drawings and accompanying parts lists for the assemblies used on this crane. These drawings are intended to be used in conjunction with the instructions found in the REPAIR section in Volume 1. For optional equipment such as winches and remote controls, refer to the appropriate service manual.

#### WARNING

DO NOT ATTEMPT TO REPAIR ANY COMPONENT WITHOUT READING THE INFORMATION CONTAINED IN THE REPAIR SECTION IN VOLUME 1. PAY PARTICULAR ATTENTION TO STATEMENTS MARKED WARNING, CAUTION, OR NOTE IN THAT SECTION. FAILURE TO COMPLY WITH THESE INSTRUCTIONS MAY RESULT IN DAMAGE TO THE EQUIPMENT, PERSONAL INJURY, OR DEATH.

### CRANE IDENTIFICATION

Every IMT crane has an identification placard (see figure) attached to the mast. When ordering parts, communicating warranty information, or referring to the unit in correspondence, always include the serial number and model numbers. All inquiries should be addressed to:

Iowa Mold Tooling Co., Inc.  
 Box 189, Garner, IA 50438-0189  
 Telephone: 515-923-3711  
 Technical Support Fax: 515-923-2424

### CYLINDER IDENTIFICATION

To insure proper replacement parts are received, it is necessary to specify the complete number/letter sequence for any part requested. Part numbers may be cross checked by comparing the stamped identification on the cylinder case (See figure below) against the information contained in the service manual. You must include the part number stamped on the cylinder case when ordering parts.

### WELDMENT IDENTIFICATION

Each of the major weldments - base, mast, inner boom, outer boom, extension boom and outrigger weldments bear a stamped part number. Any time a major weldment is replaced, you must specify the complete part number as stamped on the weldment.

### ORDERING REPAIR PARTS

When ordering replacement parts:

1. Give the model number of the unit.
2. Give the serial number of the unit.
3. Specify the complete part number. When ordering cylinder parts, or one of the main weldments, always give the stamped part number.
4. Give a complete description of the part.
5. Specify the quantity required.

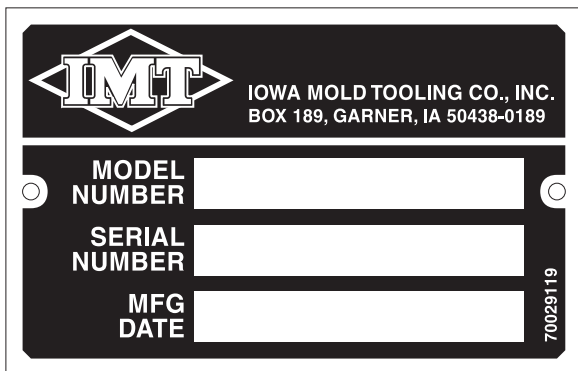

**SERIAL NUMBER PLACARD**

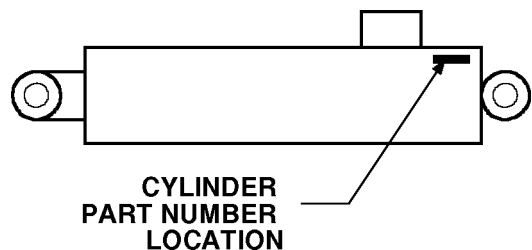

**CYLINDER PART NUMBER LOCATION**

0001225R: 41713739.01.19961212

**STEM ASM (41713739)**

ITEM	PART NO.	DESCRIPTION	QTY
1.	3B025920	CYLINDER-OUTRIGGER	2
2.	52711874	HANDLE	4
3.	52712256	LADDER-CURBSIDE	1
4.	52712255	LADDER-STREETSIDE	1
5.	52712257	STEM	1
6.	52712134	PLATFORM	2
7.	72063051	WASHER 3/8 LOCK	4
8.	52712794	OUTRIGGER LEG	2
9.	60117954	PIN RETAINER 3"	8

3-4

10.	60118622	PIN	2
11.	60117956	PIN	2
12.	72060009	CAP SCR 1/4-20X2-1/4 HHGR5	16
13.	72060025	CAP SCR 5/16-18X1 HHGR5	8
14.	72060046	CAP SCR 3/8-16X1 HHGR5	8
15.	72060047	CAP SCR 3/8-16X1-1/4 HHGR5	4
16.	72062103	NUT 3/8-16 LOCK	8
17.	72062104	NUT 1/4-20 LOCK	16
18.	72063001	WASHER 1/4 WRT	32
19.	72063003	WASHER 3/8 WRT	4
20.	72063050	WASHER 5/16 LOCK	8

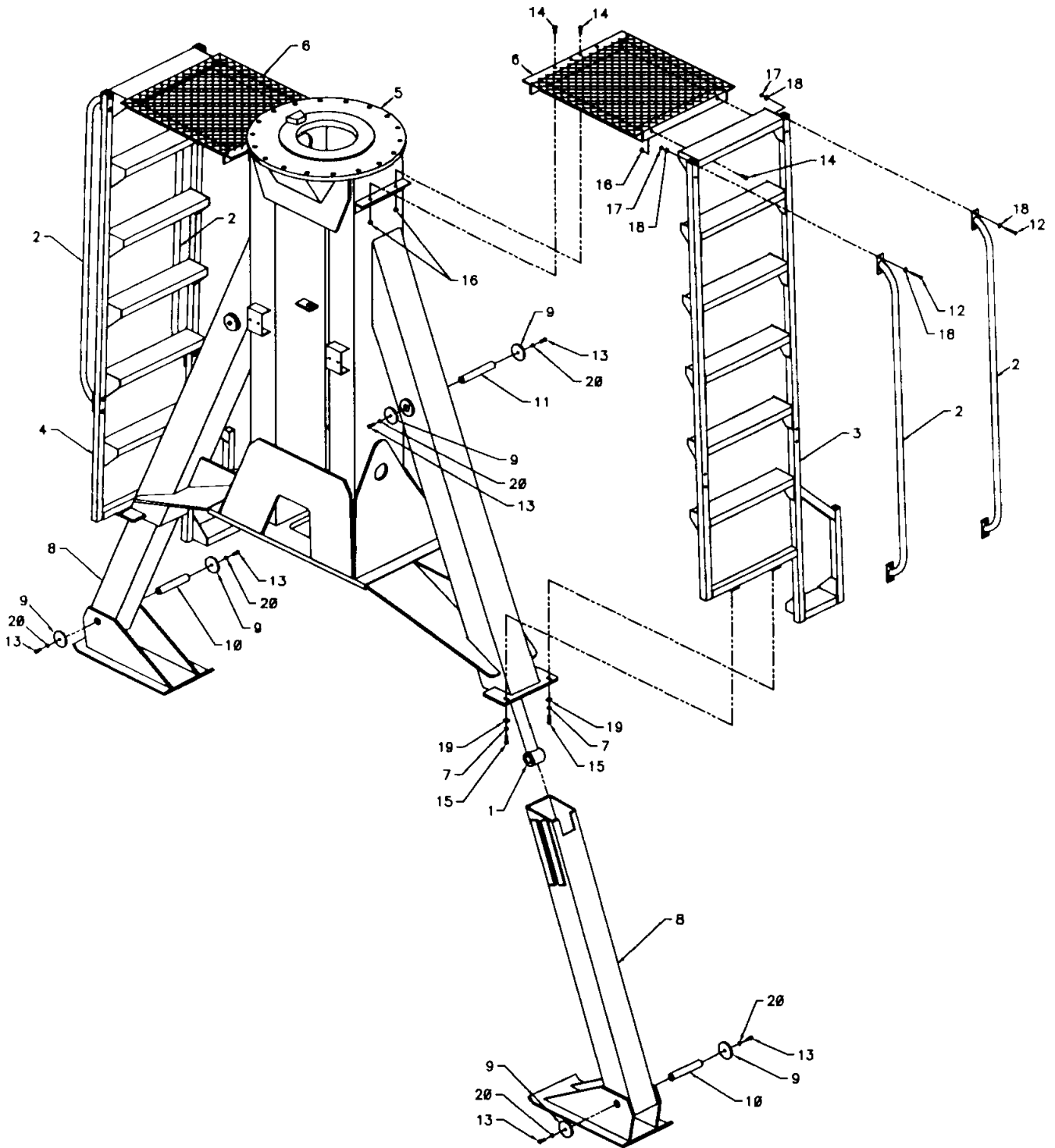

**OUTRIGGER CYLINDER (3B025920)**

ITEM	PART NO.	DESCRIPTION	QTY
1.	4B025920	CASE ASM	1
2.	4G025920	ROD ASM	1
3.	6I352144	PISTON	1
4.	6H035020	HEAD	1
5.	9B025920	SEAL KIT (INCL:6-14)	1
6.	7Q072338	O-RING (PART OF 5)	1REF
7.	7Q10P338	BACKUP RING (PART OF 5)	1REF
8.	7T2N8022	WEAR RING (PART OF 5)	1REF
9.	7R546020	U-CUP SEAL (PART OF 5)	1REF
10.	7R14P020	ROD WIPER (PART OF 5)	1REF
11.	7T61N143	LOCK RING (PART OF 5)	1REF
12.	7T2N4035	WEAR RING-PISTON(PART OF 5)	2REF
13.	7T66P350	PISTON SEAL (PART OF 5)	1REF
14.	6A025020	WAFER LOCK (PART OF 5)	1REF
15.	6C150020	STOP TUBE 1-1/2"	1
16.	6C300020	STOP TUBE 3"	1

**NOTE**

IT IS RECOMMENDED THAT ALL COMPONENTS OF THE SEAL KIT BE REPLACED WHENEVER THE CYLINDER IS DISASSEMBLED. THIS WILL REDUCE FUTURE DOWNTIME.

APPLY "LUBRIPLATE #630-2" MEDIUM HEAVY, MULTI-PURPOSE LUBRICANT OR EQUIVALENT, TO ALL PISTON AND HEAD GLANDS, HOLDING VALVE SEALS, NYLON LOCK RING, CAST IRON PISTON RINGS AND ROD THREADS.

APPLY "NEVER-SEEZ" REGULAR GRADE ANTI-SEIZE AND LUBRICATING COMPOUND TO CYLINDER HEAD THREADS. DO NOT APPLY "NEVER-SEEZ" TO ANY SEALS.

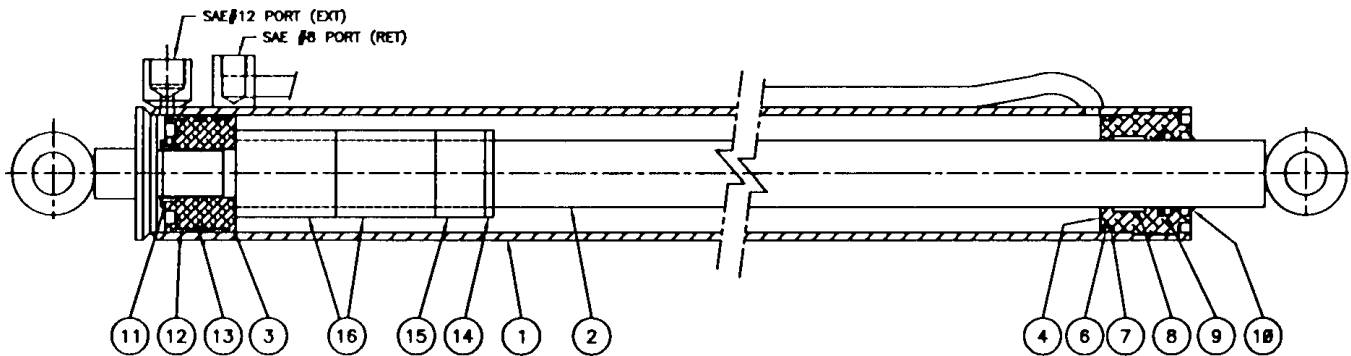

## MAST ASM-CONTINUOUS ROT'N (41713774-1)

ITEM	PART NO.	DESCRIPTION	QTY
1.	71056440	GEAR BEARING	1
2.	72601630	CAP SCR 3/4-10X3-1/2 SH	41
3.	72060186	CAP SCR 3/4-10X2-1/2 HHGR5	10
4.	70056495	GEAR BOX	1
5.	73051473	MOTOR	1
6.	72060092	CAP SCR 1/2-13X1-1/4 HHGR5	2
7.	70731795	C'BAL VALVE (INCL:39,40)	1
8.	72060091	CAP SCR 1/2-13X1 HHGR5	2
9.	71056439	PINION GEAR	1
10.	60114482	PINION CAP	1
11.	72060356	CAP SCR 1/2-20X1-1/4 HHGR5	2
12.	52710062	GEAR GUARD	1
13.	72063053	WASHER 1/2 LOCK	8
14.	60104062	SPACER	2
15.	52711046	ROTATION BRACKET	1
16.	72060093	CAP SCR 1/2-13X1-1/2 HHGR5	2
17.	72060031	CAP SCR 5/16-18X2-1/2 HHGR5	2
18.	52713825	MAST	1
19.	72053508	ZERK 1/8NPT	1
20.	72053589	STREET ELBOW 1/8NPT 90°	1
21.	53000710	GREASE EXT 29"	1
22.	52712617	CHAIR MTG BRKT	1
23.	70731411	CHAIR	1
24.	72060097	CAP SCR 1/2-13X3 HHGR5	1
25.	72062080	NUT 1/2-13 LOCK	3
26.	72063050	WASHER 5/16 LOCK	6
27.	72060025	CAP SCR 5/16-18X1 HHGR5	4
28.	71056465	HYDRAULIC BRAKE	1
29.	72053301	COUPLING 1/8NPT	1
30.	72063003	WASHER 3/8 WRT	2
31.	52711871	GRAB HANDLE (NOT SHOWN)	1
32.	72060025	CAP SCR 5/16-18X1 HHGR5	2
33.	72060029	CAP SCR 5/16-18X2 HHGR5	2
34.	72063002	WASHER 5/16 WRT	10
35.	72062109	NUT 5/16-18 LOCK	4
36.	76391497	GASKET	1
37.	76393533	GASKET	1
38.	60106032	STUD-HYD MTR	2
39.	7Q072017	O-RING	2REF
40.	73054538	CARTRIDGE VALVE	2REF

### CONTINUED

41.	72060757	CAP SCR 3/8-16X2-1/2 SH	4
42.	89044402	LOOM	2FT
43.	70067005	ADHESIVE	AR
44.	60120142	HOSE CLAMP	1
45.	72060050	CAP SCR 3/8-16X2 HHGR5	2
46.	72063003	WASHER 3/8 WRT	2
47.	72063051	WASHER 3/8 LOCK	2
48.	60106743	SPACER	1
49.	72060094	CAP SCR 1/2-13X1-3/4 HHGR5	1
50.	72063005	WASHER 1/2 WRT	1
51.	60106744	HOSE CLAMP	1
52.	52713826	BRACKET	1
53.	60120143	HOSE CLAMP	1

### WARNING

ANYTIME A GEAR-BEARING BOLT IS REMOVED, IT MUST BE REPLACED WITH A NEW BOLT OF THE IDENTICAL GRADE AND SIZE. FAILURE TO REPLACE GEAR-BEARING BOLTS MAY RESULT IN BOLT FAILURE DUE TO METAL FATIGUE, CAUSING SERIOUS INJURY OR DEATH.

### CAUTION

ANYTIME THE PINION GEAR CAP SCREWS (ITEM 11) ARE REMOVED, APPLY LOCTITE 262 TO THE THREADS BEFORE RE-ASSEMBLY.

### CAUTION

REFER TO THE TURNTABLE BEARING FASTENER TIGHTENING SEQUENCE INSTRUCTIONS IN THE REFERENCE SECTION PRIOR TO TIGHTENING TURNTABLE GEAR FASTENERS.

### NOTE

INSTALL GEAR BEARING WITH A MINIMUM GEAR BACKLASH OF .020-.030" (.508 - .762mm). MEASURED BETWEEN SWING PINION AND GEAR BEARING TEETH WITH YELLOW PAINT.

**MAST ASM-CONTINUOUS ROT'N  
(41713774-2)**

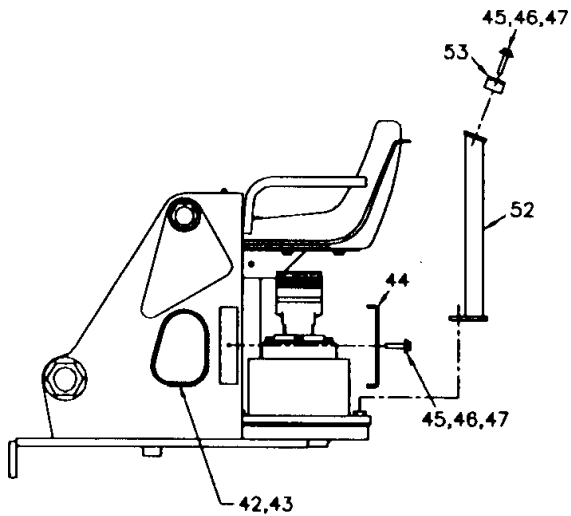

NOTE:

1. INSTALL TURNABLE GEAR BEARING WITH A MINIMUM GEAR BACKLASH OF  $.020-.030$ ", MEASURED BETWEEN SWING PINION AND TURNABLE GEAR BEARING TEETH WITH YELLOW PAINT.

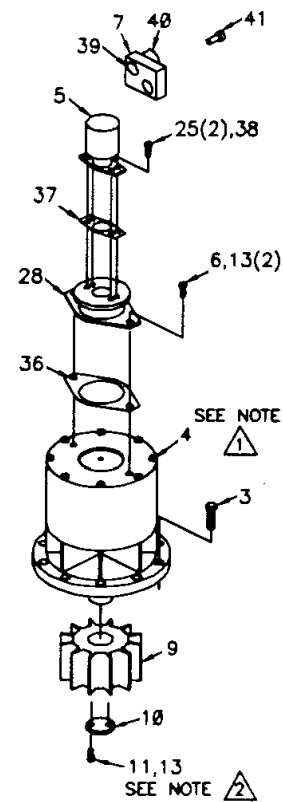
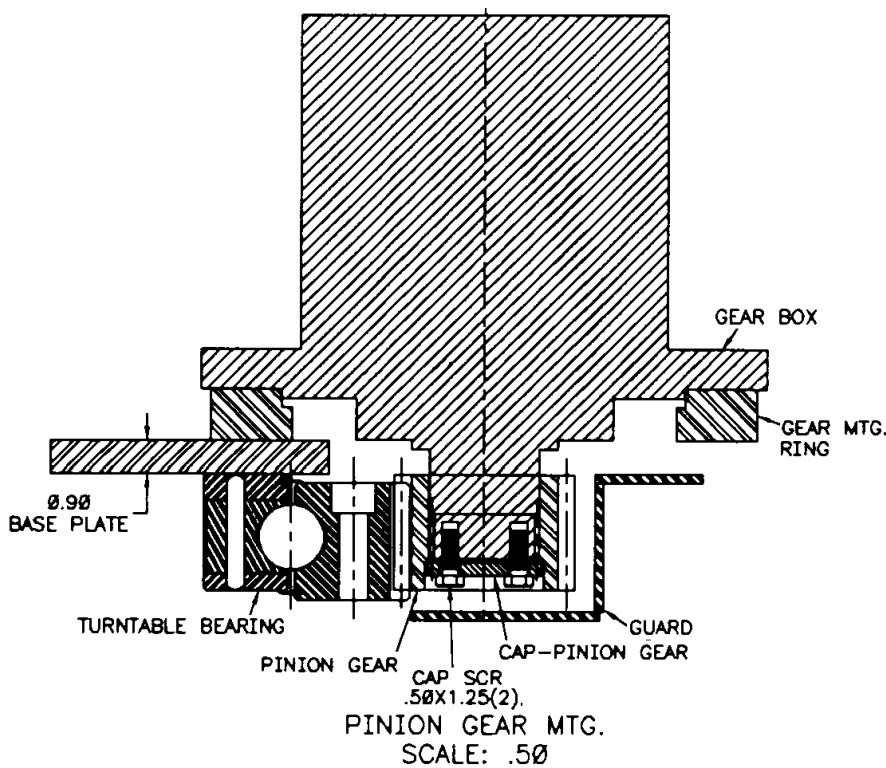
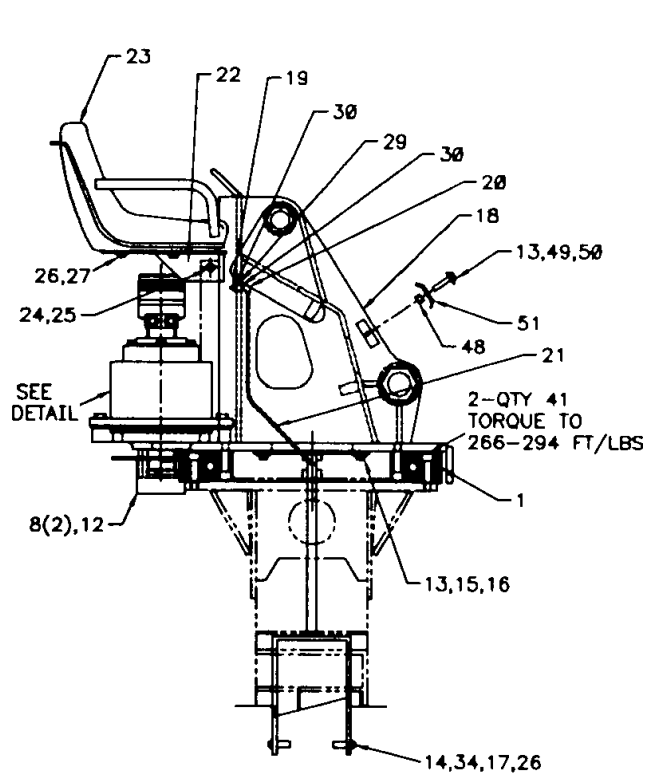

NOTE:

1. FILL WITH 4.25 PINTS OF 80/90 EP GREASE, SHOULD BE FILLED TO WITHIN 1.38" OF TOP FILL PLUG.
2. USE A CLEANER/PRIMER ON THREADS APPLY A SERVICABLE THREAD LOCKER TORQUE CAP SCREWS TO 75 FT-LBS.

0001225R: 71056465.01.19961212

3-8

**ROTATION BRAKE (71056465)**

ITEM	PART NO.	DESCRIPTION	QTY
1.	70144103	COVER	1
2.	70144113	CASE	1
3.	70144114	BASE	1
4.	70144115	PISTON	1
5.	70144116	SHAFT	1
6.	76393541	GASKET	1
7.	76393540	BASE GASKET	1
8.	70055234	BEARING	1
9.	70055235	BEARING	1
10.	72601660	CAP SCR 12POINT 1/2-13X1	4
11.	72601659	CAP SCR #10-24X3/4 SH	6

12.	76393535	BACKUP RING	1
13.	76393536	BACKUP RING	1
14.	76393537	O-RING	1
15.	76393538	O-RING	1
16.	76393539	SEAL	1
17.	72533261	HEX PLUG	1
18.	70144117	SPRING	10
19.	70144118	FRICITION DISC	8
20.	70144111	SEPARATOR PLATE	7
21.	76393534	O-RING	1
22.	76393533	GASKET	1
23.	70144112	SPACER-NOT USED	
24.	M72053240	PLUG	4

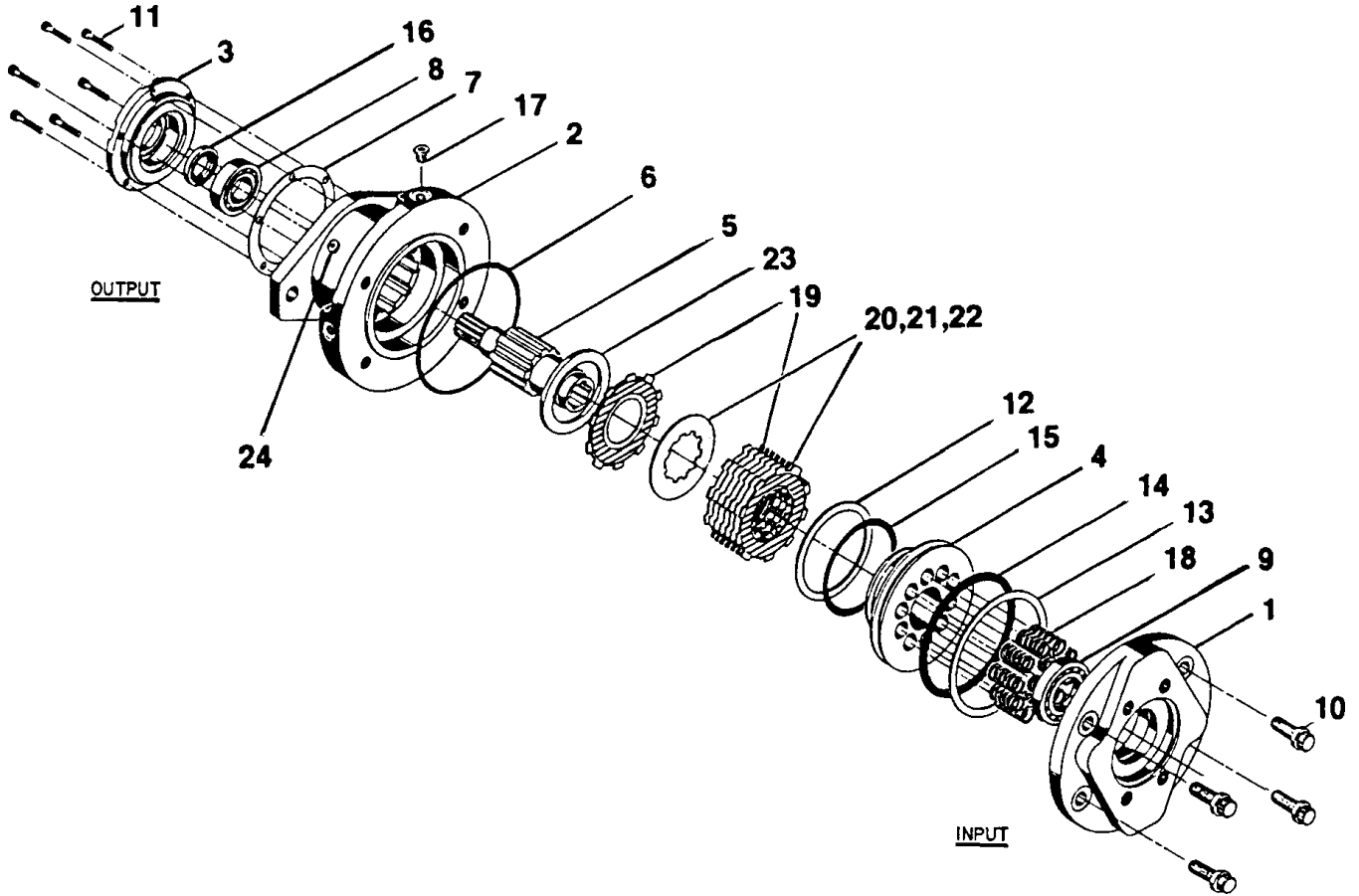



**INNER BOOM ASM (41713758)**

ITEM	PART NO.	DESCRIPTION	QTY
1.	52713846	INNER BOOM 22'	1
2.	52710034	PIN	1
3.	3C274960	INNER CYLINDER	1
4.	72060029	CAP SCR 5/16-18X2 HHGR5	7
5.	70143829	COVER PLATE	9
6.	70034432	TUBE CLAMP 2-HOLE	11
7.	72062250	NUT 2-12 LOCK	2
8.	72053508	ZERK 1/8NPT	4
9.	52710471	PIN	2
10.	72062241	NUT 1-1/5 LOCK	2
11.	52710035	PIN	1
12.	70145464	HYD TUBE ASM 1/2X66	2
13.	70145465	HYD TUBE ASM 1/2X131	6
14.	72060034	CAP SCR 5/16-18X3-1/4 HHGR5	2

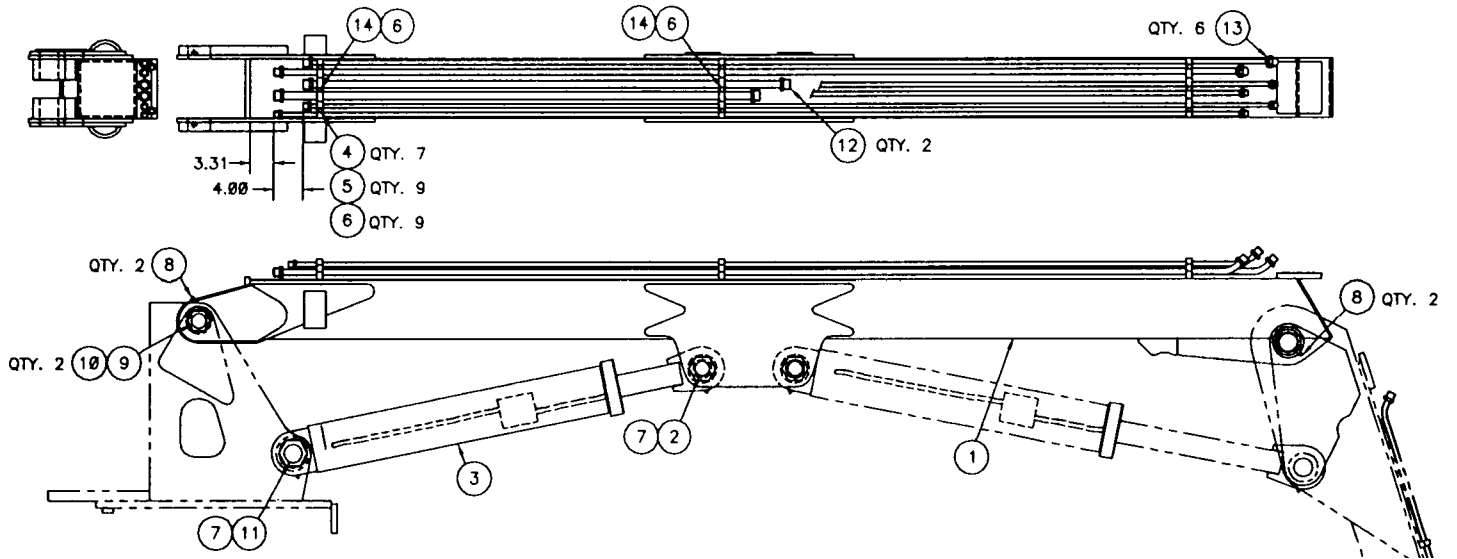

**INNER/OUTER BOOM CYLINDER  
(3C274960)**

ITEM	PART NO.	DESCRIPTION	QTY
1.	4C274960	CASE ASM (INCL:3,4)	1
2.	4G019920	ROD ASM (INCL:3,4)	1
3.	72053508	ZERK 1/8NPT (PART OF 1 & 2)	2REF
4.	70143838	BALL BUSHING (PART OF 1&2)	2REF
5.	6I603200	PISTON	1
6.	6H060030	HEAD	1
7.	9B019920	SEAL KIT (INCL:8-17)	1
8.	7Q072358	O-RING (PART OF 7)	1REF
9.	7Q10P358	BACKUP RING (PART OF 7)	1REF
10.	7T2N8032	WEAR RING-.5" (PART OF 7)	1REF
11.	7T2N4032	WEAR RING-1" (PART OF 7)	1REF
12.	7R546030	U-CUP (PART OF 7)	1REF
13.	7R14P030	ROD WIPER (PART OF 7)	1REF
14.	7T61N200	LOCK RING (PART OF 7)	1REF
15.	M7T66P060	PISTON SEAL (PART OF 7)	1REF
16.	7T2N4060	WEAR RING (PART OF 7)	2REF
17.	6A025030	WAFER LOCK (PART OF 7)	1REF
18.	73054242	C'BAL VALVE 25GPM	2

**NOTE**

IT IS RECOMMENDED THAT ALL COMPONENTS OF THE SEAL KIT BE REPLACED WHENEVER THE CYLINDER IS DISASSEMBLED. THIS WILL REDUCE FUTURE DOWNTIME.

APPLY "LUBRIPLATE #630-2" MEDIUM HEAVY, MULTI-PURPOSE LUBRICANT OR EQUIVALENT, TO ALL PISTON AND HEAD GLANDS, HOLDING VALVE SEALS, NYLON LOCK RING, CAST IRON PISTON RINGS AND ROD THREADS.

APPLY "NEVER-SEEZ" REGULAR GRADE ANTI-SEIZE AND LUBRICATING COMPOUND TO CYLINDER HEAD THREADS. DO NOT APPLY "NEVER-SEEZ" TO ANY SEALS.

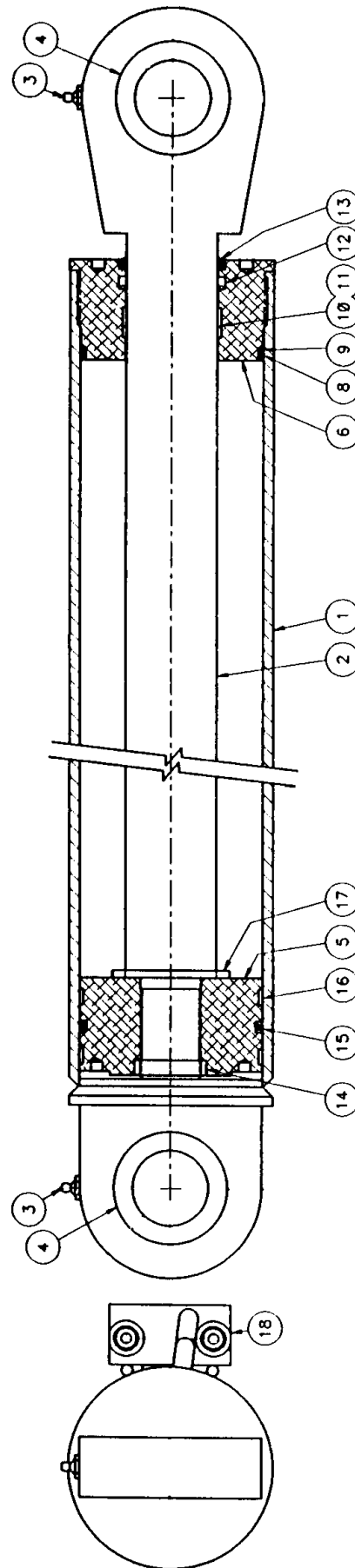

### OUTER/EXTENSION BOOM ASM (41713759)

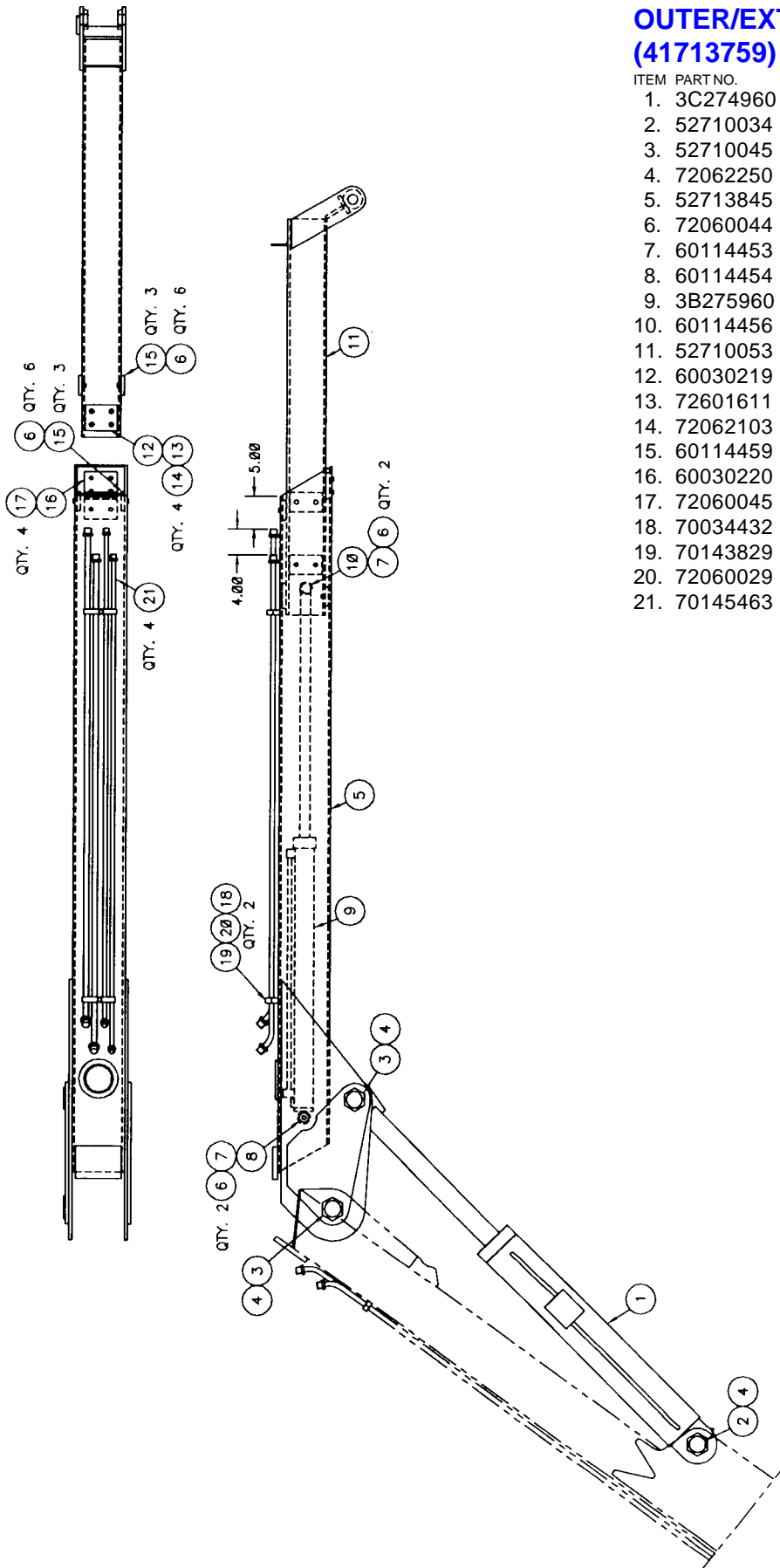

ITEM	PART NO.	DESCRIPTION	QTY
1.	3C274960	OUTER CYLINDER	1
2.	52710034	PIN	1
3.	52710045	PIN	2
4.	72062250	NUT 2-12 LOCK	3
5.	52713845	END BOOM	1
6.	72060044	CAP SCR 3/8-16X3/4 HH GR5	16
7.	60114453	WASHER	4
8.	60114454	PIN	1
9.	3B275960	EXTENSION CYLINDER	1
10.	60114456	PIN	1
11.	52710053	EXTENSION BOOM	1
12.	60030219	SLIDE BUSHING	1
13.	72601611	MACH SCR 3/8-16X1-1/2	4
14.	72062103	NUT 3/8-16 LOCK	4
15.	60114459	SLIDE SPACER	6
16.	60030220	SLIDE BUSHING	1
17.	72060045	CAP SCR 3/8-16X7/8 HHGR5	4
18.	70034432	TUBE CLAMP 2-HOLE	4
19.	70143829	COVER PLATE	4
20.	72060029	CAP SCR 5/16-18X2 HHGR5	4
21.	70145463	HYD TUBE ASM 1/2X76	4

**EXTENSION BOOM CYLINDER  
(3B275960)**

ITEM	PART NO.	DESCRIPTION	QTY
1.	4B275960	CASE ASM	1
2.	4G339910	ROD ASM	1
3.	6I302125	PISTON	1
4.	6H030020	HEAD	1
5.	6C075020	STOP TUBE 3/4	1
6.	9C156920	SEAL KIT (INCL:7-16)	1
7.	6A025020	WAFER LOCK (PART OF 6)	1REF
8.	7T66P300	PISTON SEAL (PART OF 6)	1REF
9.	7T61N125	LOCK RING (PART OF 6)	1REF
10.	7T2N4030	WEAR RING-1" (PART OF 6)	2REF
11.	7Q072124	O-RING (PART OF 6)	1REF
12.	7Q072334	O-RING (PART OF 6)	1REF
13.	7Q10P334	BACKUP RING (PART OF 6)	1REF
14.	7T2N4022	WEAR RING (PART OF 6)	1REF
15.	7R546020	U-CUP (PART OF 6)	1REF
16.	7R14P020	ROD WIPER (PART OF 6)	1REF
17.	73054242	C'BAL VALVE 25GPM	2

**NOTE**

IT IS RECOMMENDED THAT ALL COMPONENTS OF THE SEAL KIT BE REPLACED WHENEVER THE CYLINDER IS DISASSEMBLED. THIS WILL REDUCE FUTURE DOWNTIME.

APPLY "LUBRIPLATE #630-2" MEDIUM HEAVY, MULTI-PURPOSE LUBRICANT OR EQUIVALENT, TO ALL PISTON AND HEAD GLANDS, HOLDING VALVE SEALS, NYLON LOCK RING, CAST IRON PISTON RINGS AND ROD THREADS.

APPLY "NEVER-SEEZ" REGULAR GRADE ANTI-SEIZE AND LUBRICATING COMPOUND TO CYLINDER HEAD THREADS. DO NOT APPLY "NEVER-SEEZ" TO ANY SEALS.

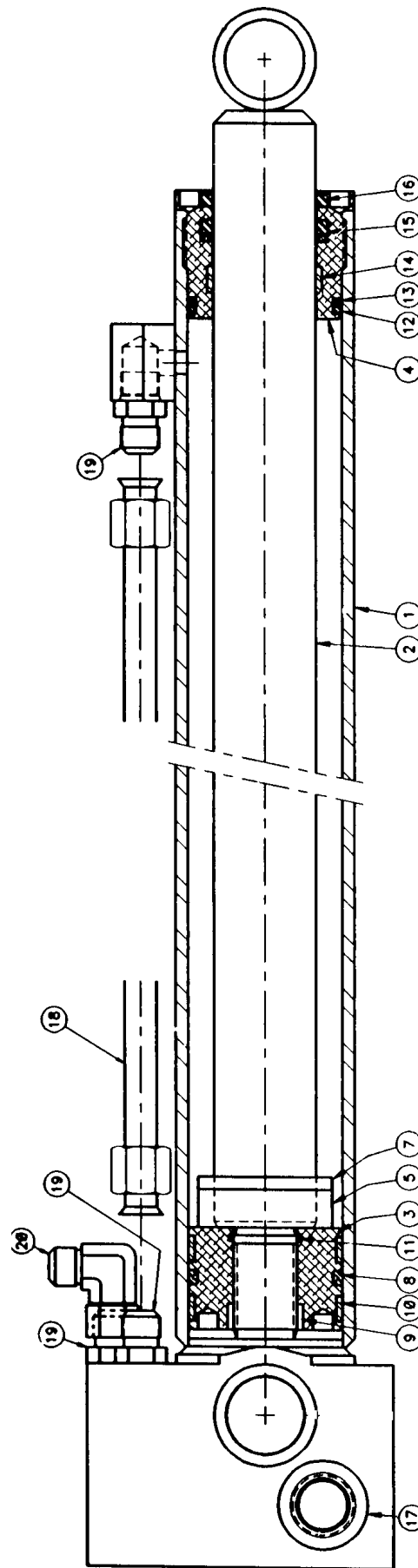

**VALVEBANK ASM 8-SECT (51713856)**

ITEM	PART NO.	DESCRIPTION	QTY
1.	70732479	VALVEBANK 8-SECTION	1
2.	72532360	ADAPTER #12MSTR #8MJIC	16
4.	72053770	ELBOW #16MSTR #16MJIC 90°	1
5.	72531131	STREET ELBOW 1/4NPT 90°	1
6.	72032987	NIPPLE 1/4DIAG DISCONNECT	2
7.	60116153	ELBOW-PR GAUGE MOD	1
8.	72532971	ELBOW #16MJIC #16FJIC	1
9.	72532370	ADAPTER #16MSTR #16MJIC	2
10.	60119318	ELBOW-PR GAUGE MOD#16#16	1

**NOTE**

PLASTIC CAPS ON EXPOSED FITTING ENDS ARE TO REMAIN ON THE FITTINGS UNTIL THE VALVEBANK IS INSTALLED.

NOTES:

1. PLASTIC CAPS ON EXPOSED FITTING ENDS ARE TO REMAIN ON THE FITTINGS UNTIL VALVE BANK IS USED IN THE HYDRAULIC INSTALLATION.

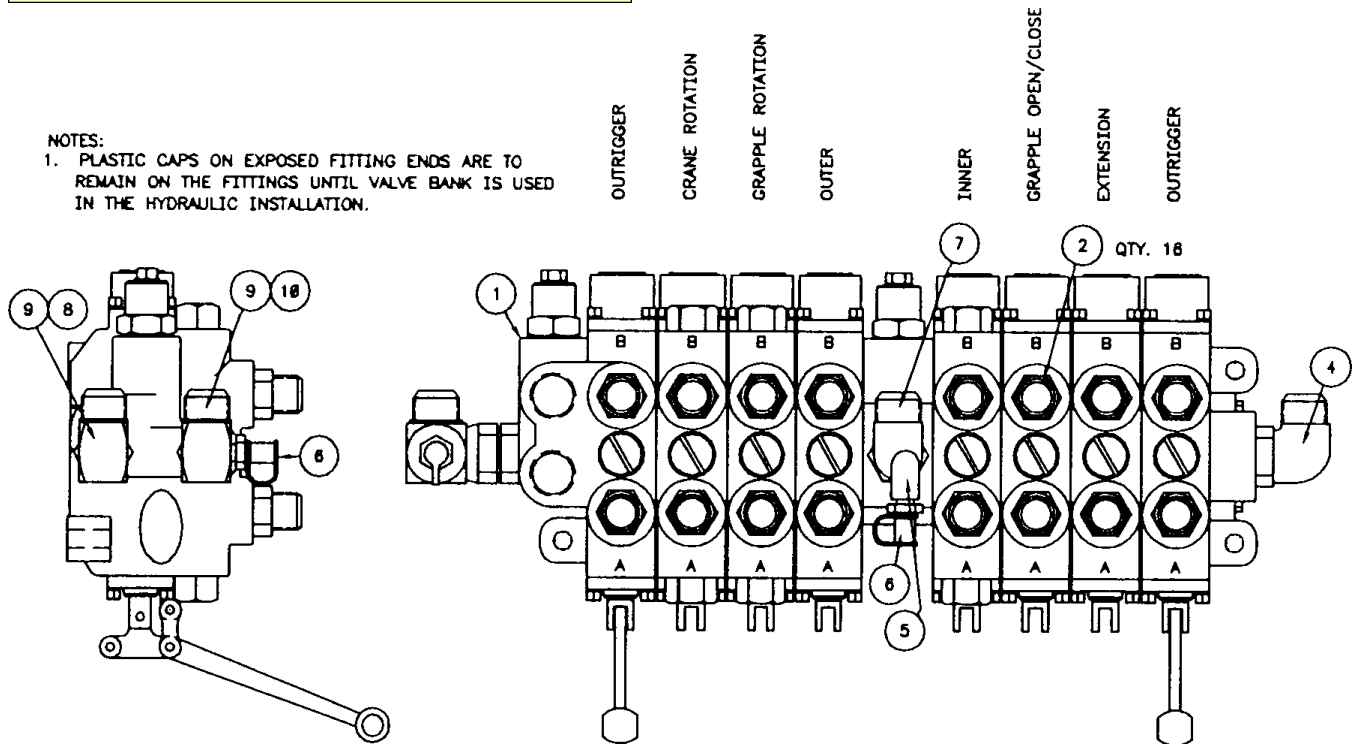

**CONTROL KIT-4 WAY (41712420-1)**

CONTINUED

ITEM	IMT PART NO.	DESCRIPTION	QTY
2.	52710091	HANDLE LH	1
3.	52710092	HANDLE RH	1
4.	52710093	BELL CRANK	5
5.	52710094	CONTROL ROD	6
6.	52710095	PEDAL	1
7.	60114453	WASHER .41 ID X 1-3/4 OD X .09	2
8.	60118301	PIVOT PIN	1
9.	60114591	STUD 3/8-24X3	1
10.	60114592	STUD 3/8-24X9	4
11.	70058201	CROSS & BRG KIT	2
13.	70732480	BALL JOINT	6
14.	71393327	KNOB 1-1/2	3
15.	71580054	CLEVIS	10

16.	72053508	ZERK 1/8NPT	7
17.	72060044	CAP SCR 3/8-16X3/4 HH GR5	3
18.	72060096	CAP SCR 1/2-16X2-1/2 HH GR5	3
19.	72062080	NUT 1/2-13 HEX	3
20.	72062037	NUT 3/8-24 HEX	22
21.	72063034	MACH BUSHING 1X10GA	1
22.	52712421	LEVER-EXT	1
23.	72066336	COTTER PIN-SPCL SHORT	6
24.	72066168	COTTER PIN 3/32X3/4	10
25.	72066180	COTTER PIN 1/8X1-1/2	1
26.	72066337	PIN-SPCL	6
27.	72661391	CLEVIS PIN 3/8X1-1/16	10
28.	70024339	BUSHING	12REF

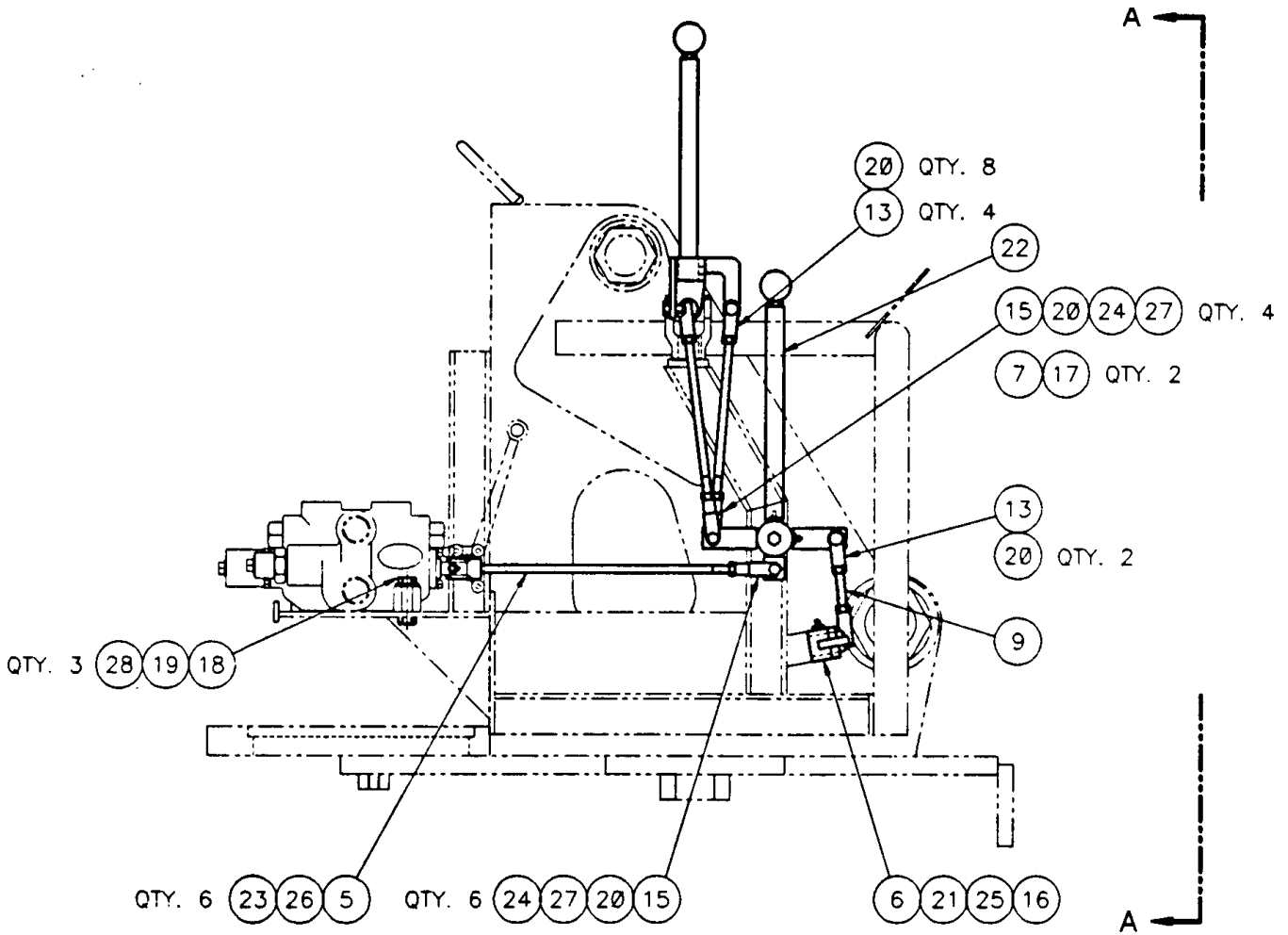

**CONTROL KIT-4 WAY (41712420-2)**

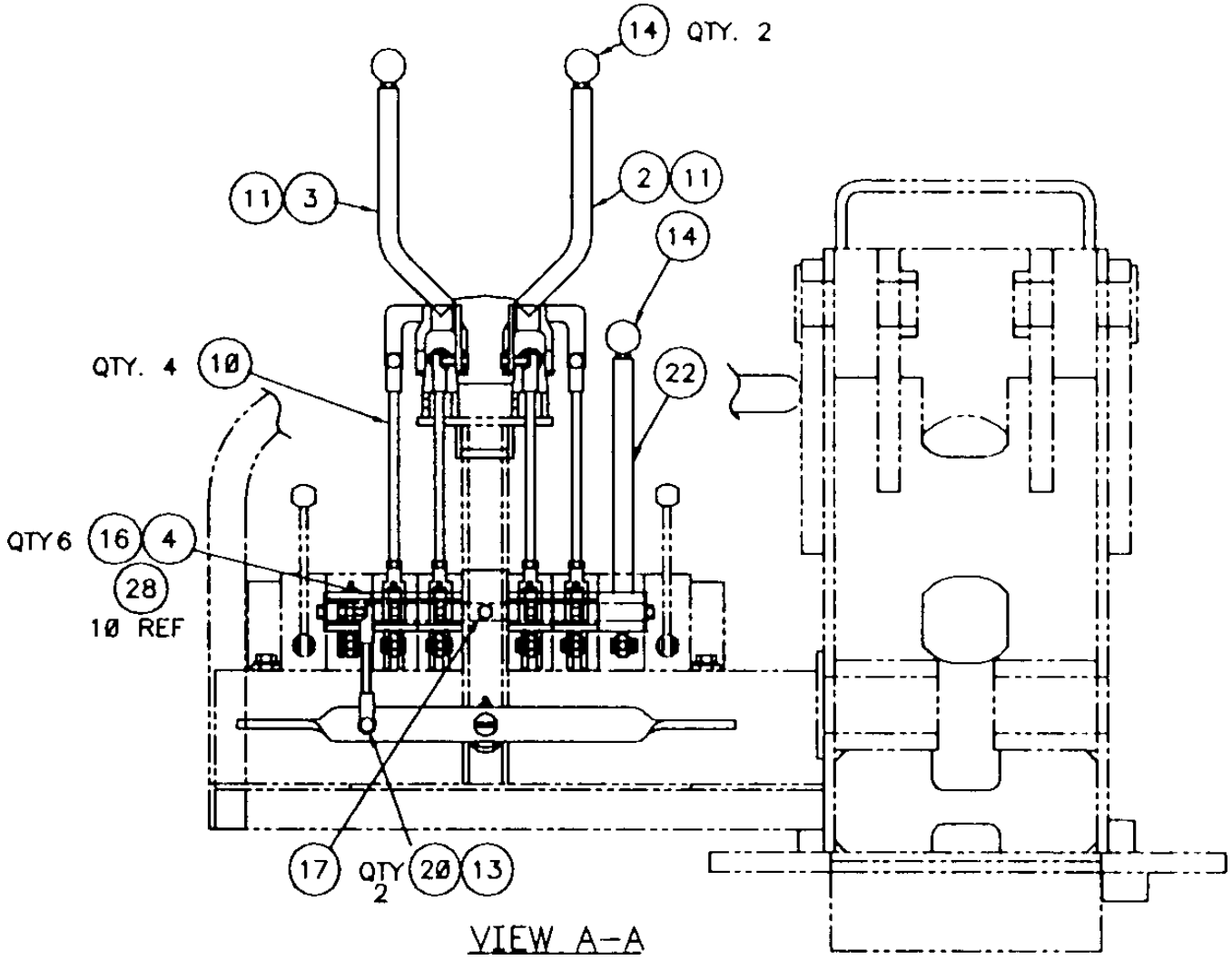

0001225R: 91713762.01.19980106

3-16

**HYDRAULIC KIT-8F (91713762-1)**

ITEM	IMT PART NO.	DESCRIPTION	QTY
2.	51712102	HOSE ASM 1/4X10 #4#4 FF	1
3.	51714309	HOSE ASM 1/2X38 #8#8 FZ	1
4.	51714308	HOSE ASM 1/2X38 #8#8 FJ	1
5.	51713848	HOSE ASM 1/2X59 #8#8 FZ	1
6.	51713849	HOSE ASM 1/2X56 #8#8 FJ	1
7.	51713830	HOSE ASM 1/2X68 #8#8 FZ	2
8.	51714310	HOSE ASM 1/2X86 #8#8 FZ	1
9.	51713839	HOSE ASM 1/2X69 #8#8 FZ	1
10.	72053770	ELBOW #16MSTR #16MJIC 90°	4
11.	51713851	HOSE ASM 1/2X83 #8#8 FZ	1
12.	51713852	HOSE ASM 1/2X80 #8#8 FJ	2
13.	51713831	HOSE ASM 1/2X68 #8#8 FJ	2
14.	51713840	HOSE ASM 1/2X69 #8#8 FJ	1
15.	51713842	HOSE ASM 1/2X92 #8#8 FJ	1
16.	51712272	HOSE ASM 1X84 #16#16 FF	1
17.	51712274	HOSE ASM 1X108 #16#16 FF	2
18.	51712273	HOSE ASM 1X96 #16#16 FF	1
19.	72532358	ADAPTER #8MSTR #8MJIC	4
20.	51712271	HOSE ASM 1X60 #16#16 FF	4
21.	51708697	HOSE ASM 1/2X21 #8#8 FF	2
22.	51704959	HOSE ASM 1/2X16 #8#8 FF	2
23.	51713357	HOSE ASM 1/2X22 #8#8 FJ	4
24.	51713838	HOSE ASM 1/2X53 #8#8 FF	1
25.	51713828	HOSE ASM 1/2X42 #8#8 FF	4
26.	51710552	HOSE ASM 1/2X47 #8#8 FF	1

27.	73054783	VELOCITY FUSE 37GPM #12#12	2
28.	72053763	ELBOW #8MSTR #8MJIC	10
29.	73054795	HOLDING VALVE	2
30.	72532359	ADAPTER #10MSTR #8MJIC	8
31.	72532972	ADAPTER #8MJIC #12FJIC	2
33.	72053789	ADAPTER #8MSTR 3/8FPT	2
34.	72053723	ADAPTER 3/8MPT 3/8MPT HEX	2
35.	73054138	COLOR FLOW NEEDLE VALVE	2
36.	72053670	ADAPTER #8MJIC 3/8MPT	2
37.	72532351	ADAPTER #4MSTR #4MJIC	1
38.	72532370	ADAPTER #16MSTR #16MJIC	4
39.	72060094	CAP SCR 1/2-13X1-3/4 HHGR5	2
40.	72062080	NUT 1/2-13 LOCK	2
41.	72063005	WASHER 1/2 WRT	4
42.	70732811	HYD MANIFOLD	1
43.	72060031	CAP SCR 5/16-18X2-1/2 HHGR5	4
44.	72062109	NUT 5/16-18 LOCK	4
45.	72063002	WASHER 5/16 WRT	8
46.	51713853	HOSE ASM 1/2X82 #8#8 FZ	1
48.	51705062	HOSE ASM 1/2X48 #8#8 FF	2
49.	51710558	HOSE ASM 1/2X54 #8#8 FF	4
50.	51711637	HOSE ASM 1/2X54 #10#8 FF	2
51.	72533101	DISCONNECT COUPLER 3/8FPT	1
52.	72533102	DISCONNECT NIPPLE 3/8FPT	1
53.	72532996	DISCONNECT COUPLER 1/2FPT	1
54.	72533118	DISCONNECT NIPPLE 1/2FPT	1
55.	72053670	ADAPTER 3/8MPT #8MJIC	2
56.	72053673	ADAPTER 1/2MPT #10MJIC	2

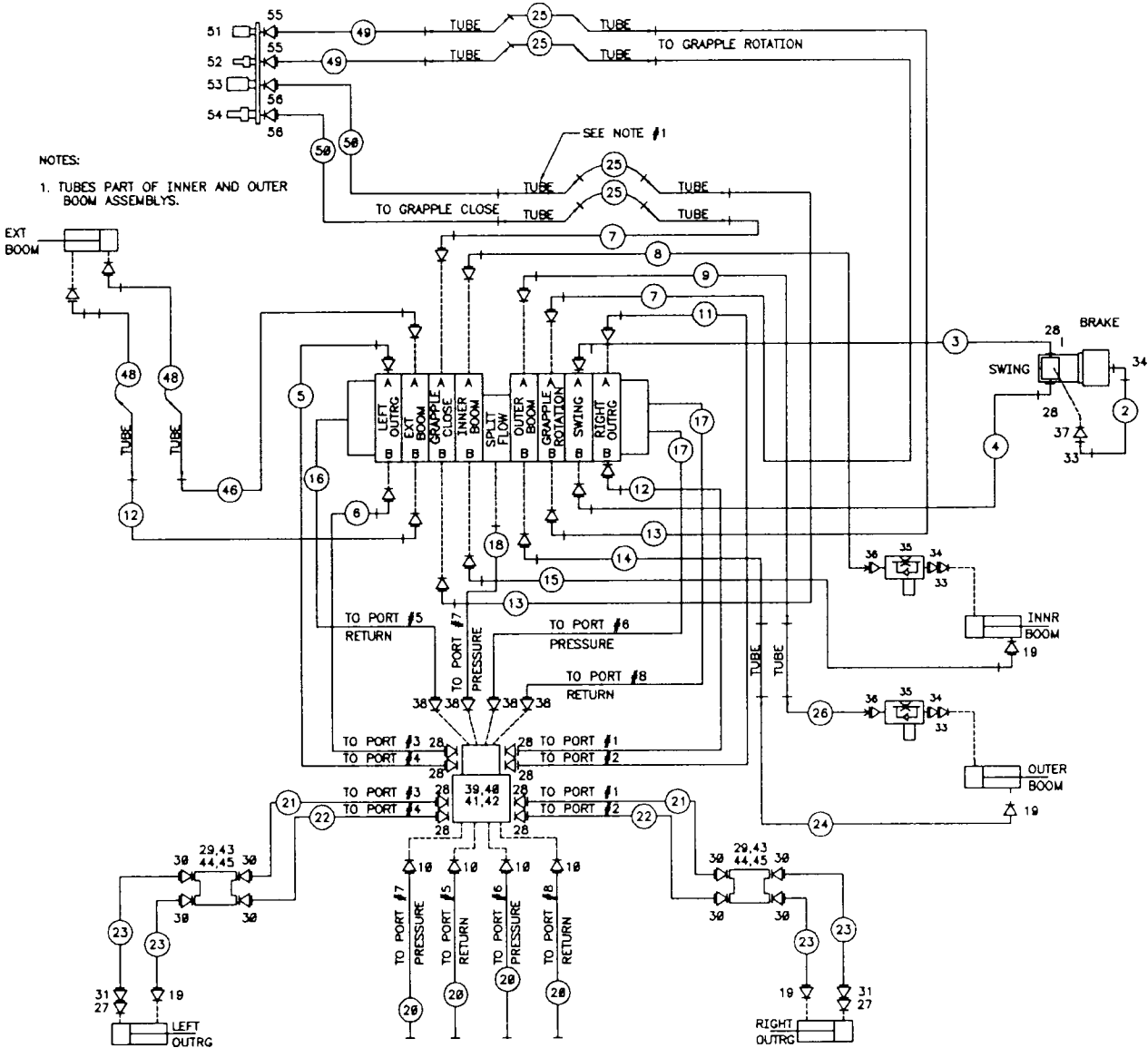



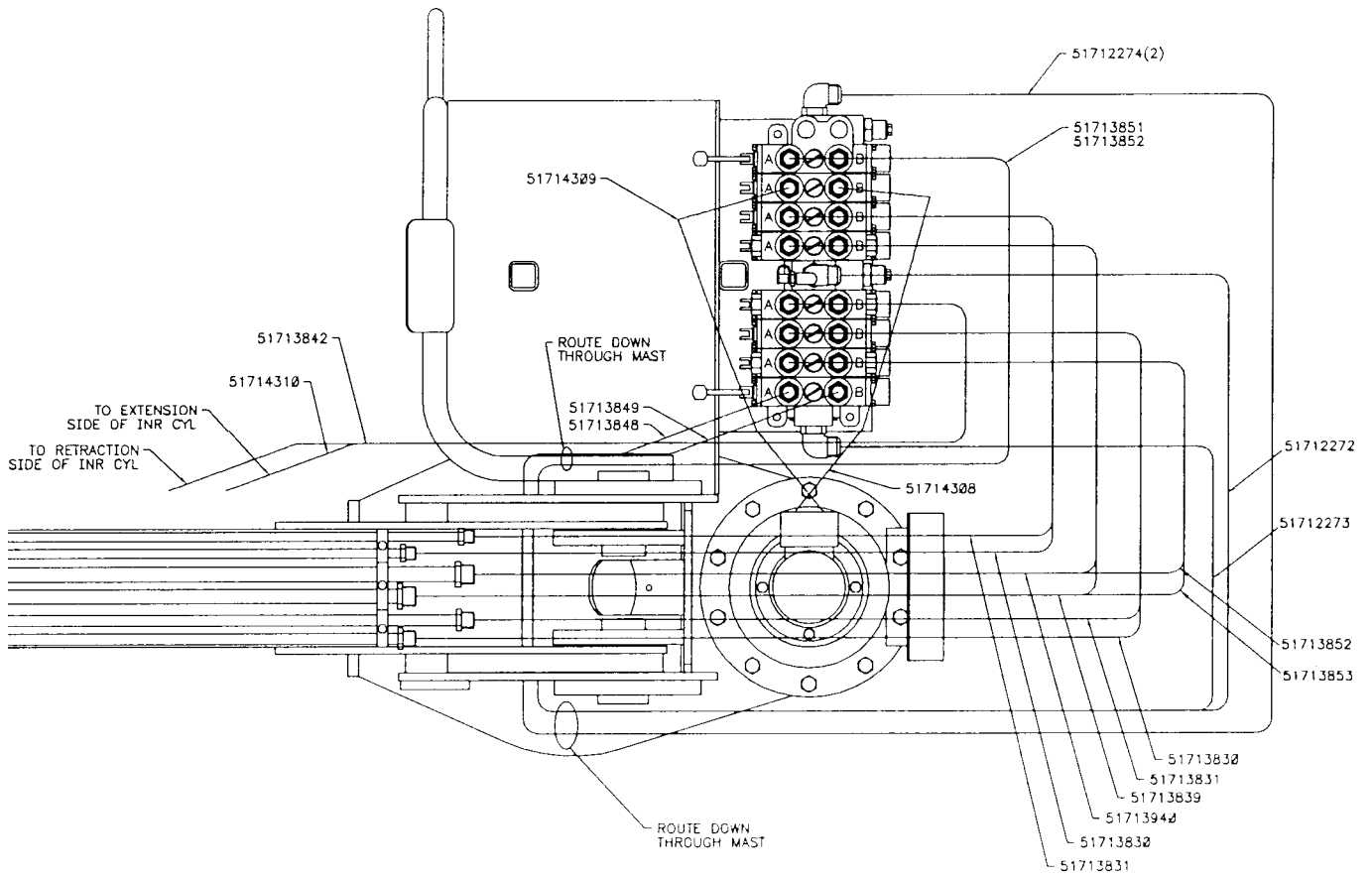

**HYDRAULIC KIT-8F (91713762-3)**

CONTINUED

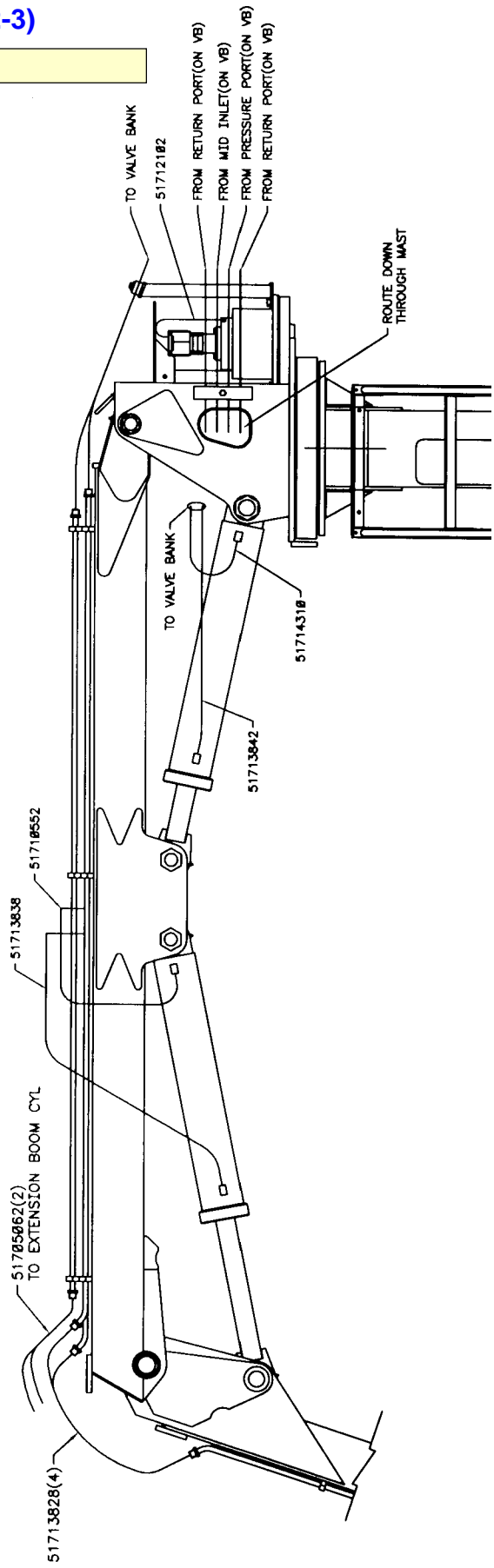

**HYDRAULIC KIT-8F (91713762-4)**

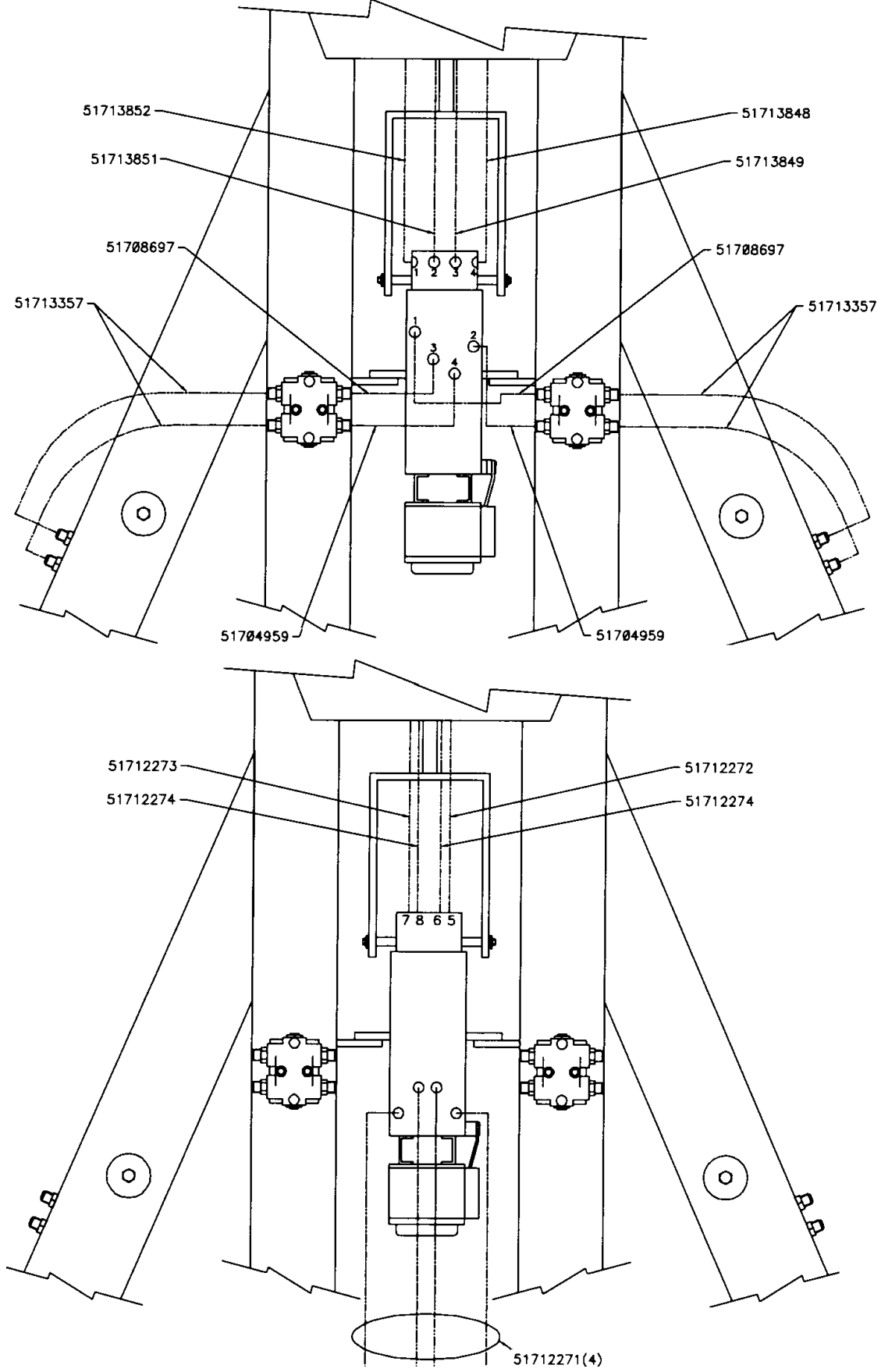

**INSTALLATION KIT-FRONT MOUNT  
(93712607)**

ITEM	PART NO.	DESCRIPTION	QTY
1.	72060095	CAP SCR 1/2-13X2 HHGR5	4
2.	72062080	NUT 1/2-13 LOCK	4
3.	52706660	FRAME SUPPORT	4
4.	72053215	PIPE NIPPLE 1-1/4NPT X 4	4
5.	70732928	RESERVOIR ASM	1
	70732791	SCREEN 100 MESH	REF
6.	72531837	REDUCER BUSHING 1-1/4X1	2
7.	73052091	FILTER	2
	73052014	ELEMENT 25MIC	REF
8.	70392108	DECAL-SUCTION LINE	2
9.	70392109	DECAL-RETURN LINE	2
10.	51710250	HOSE ASM 1X98 FF	2
11.	51710252	HOSE ASM 1X59 FF	2
12.	60114509	CLAMP PLATE	4

13.	72053680	ADAPTER 1MPT #16MJIC	2
14.	72062142	NUT 1 1/4-7 LOCK STL INS GR5	16
15.	72066516	HOSE CLAMP 1-1/4 2-BOLT	4
16.	72531530	BARB NIPPLE #20 STL	2
17.	72063067	WASHER 1-1/4 HI-STRENGTH	16
18.	60106690	TIE-DOWN STUD 1-1/4X20	8
19.	60035599	HOSE 1-1/4 100R4 X24"	2
20.	73054130	GATE VALVE	2
21.	72532371	ADAPTER #20MSTR #16MJIC	2
22.	72532662	PLUG 3/4NPT	1
23.	72532346	BARB NIPPLE 1-1/4 X 1-1/4NPT	2
24.	72062103	NUT 3/8-16 LOCK	4
25.	72063003	WASHER 3/8 WRT	4
27.	70145017	STRAP	2
28.	52712298	TANK BRACKET-LH	1
29.	52712297	TANK BRACKET-RH	1

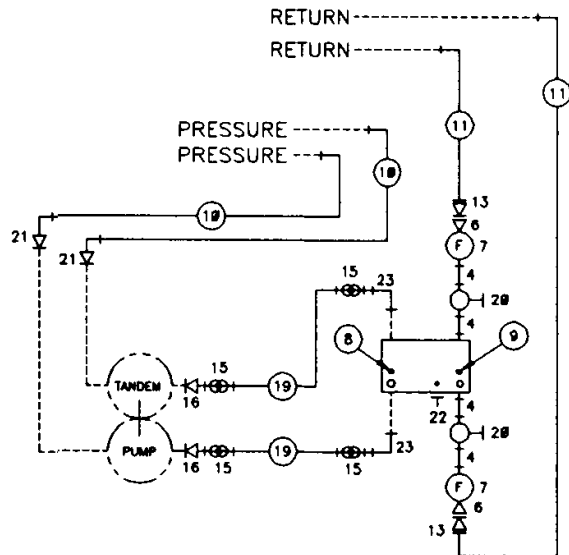
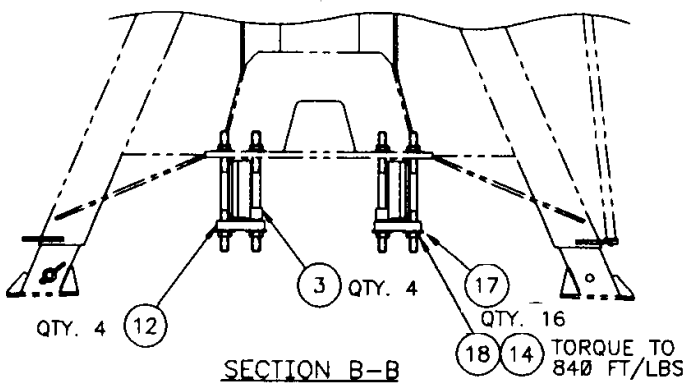
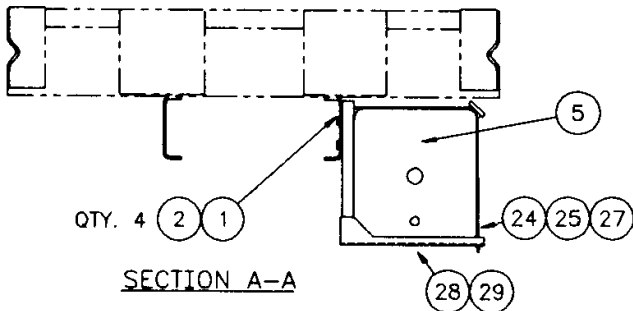
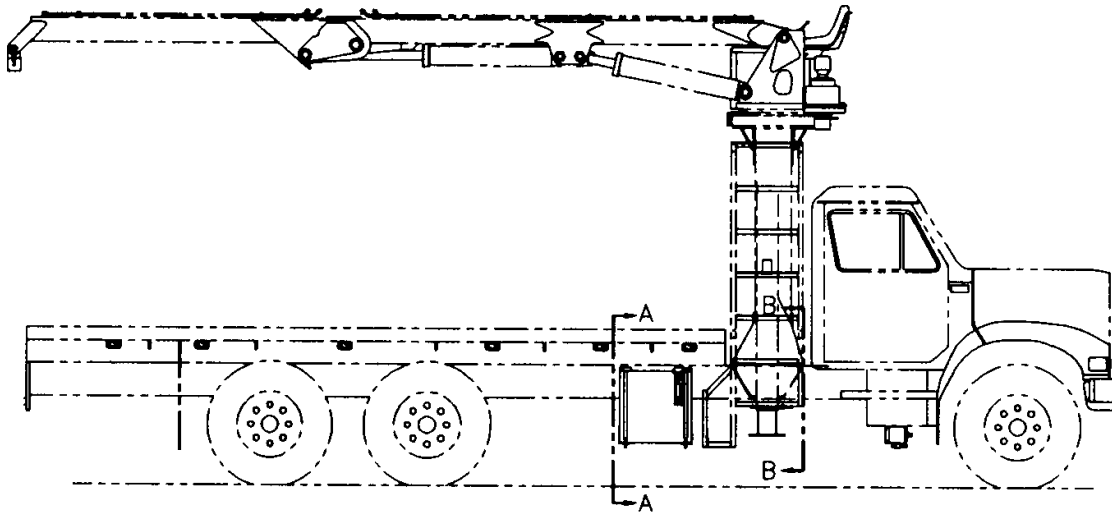

**DECAL KIT (95712423)**

ITEM	IMT PART NO.	DESCRIPTION	QTY
1.	70391612	DECAL-GREASE WEEKLY L	5
2.	70391613	DECAL-GREASE WEEKLY R	4
3.	70392213	DECAL-CAUTION WASH/WAX	1
4.	70392524	DECAL-ROTATE/GREASE	1
8.	70392864	DECAL-DANGER OR STD CLR	2
9.	70392865	DECAL-DANGER ELEC HZD	4
12.	70392982	DECAL-CONTACT IMT	1
13.	70393403	DECAL-IMT/HAWK LOGO	2
14.	70393960	DECAL-JOYSTICK CNTRL W/EXT 1	

15.	70393416	DECAL-H1200 IDENTIFICATION	2
16.	71039134	DECAL-CAUTION OIL LEVEL	2
17.	70029119	SERIAL NUMBER PLACARD	1
18.	72066340	RIVET	2
19.	71393414	CAP. CHART-UNDERSLUNG	1
20.	70392867	DECAL-DANGER OR MOVING	2
21.	70392891	DECAL-DANGER DRIVELINE	1
22.	70394189	DECAL-RECOMMEND HYD OIL	1
23.	70392868	DECAL-DANGER LOADLINE	4
24.	70392863	DECAL-DANGER HOIST PERS	2
25.	70394764	DECAL-DANGER 5-COMBINED	2

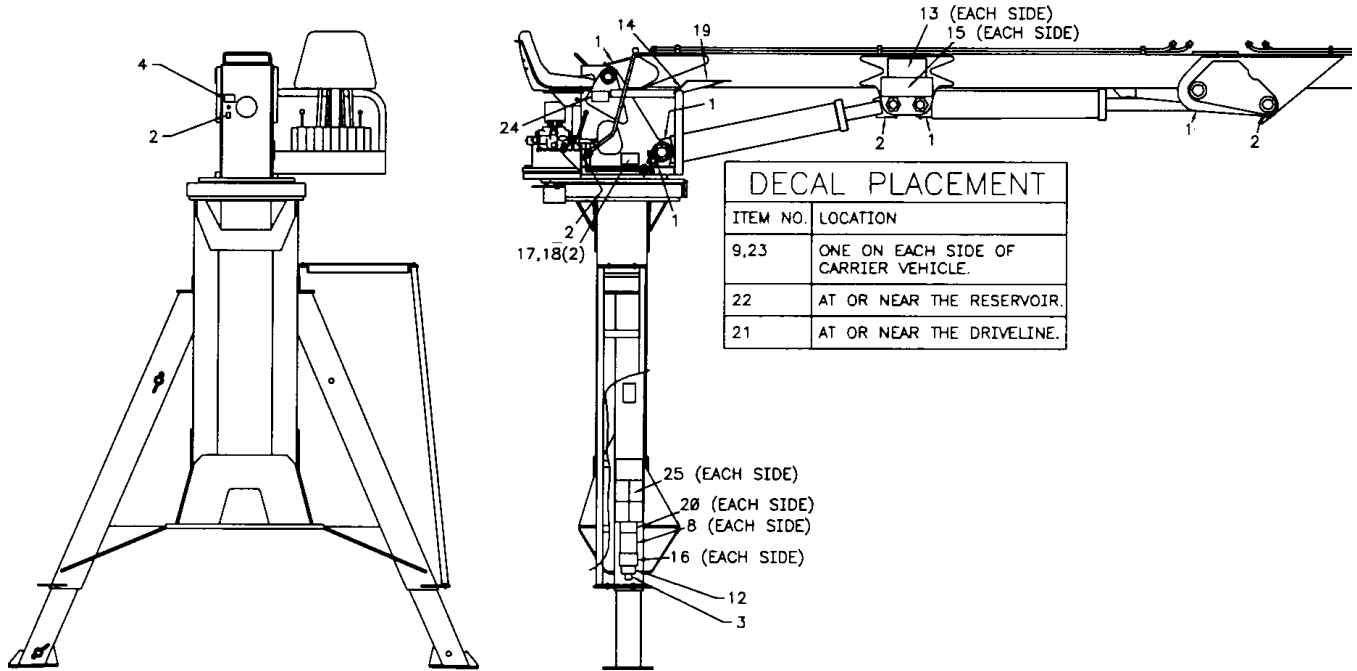

**GRAPPLE MOUNTING KIT-NON DAMPENED-S&L (51711384)**

ITEM	PART NO.	DESCRIPTION	QTY
2.	52710148	PIN	1
5.	60117238	SWIVEL LINK	1
6.	72053508	ZERK 1/8NPT	2
7.	72062257	NUT 1 1/4-12 LOCK	1
8.	72532996	DISCONNECT COUPLER 1/2FPT	1
9.	72533118	DISCONNECT NIPPLE 1/2FPT	1
10.	72533101	DISCONNECT COUPLER 3/8FPT	1
11.	72533102	DISCONNECT NIPPLE 3/8FPT	1
12.	72053497	ADAPTER 1/2MPT #8MJIC	2
13.	72053670	ADAPTER 3/8MPT #8MJIC	2
14.	51710674	HOSE ASM 3/8X48 FJ	4
15.	72531420	ELBOW 3/8MPT #8MJIC 90°	4

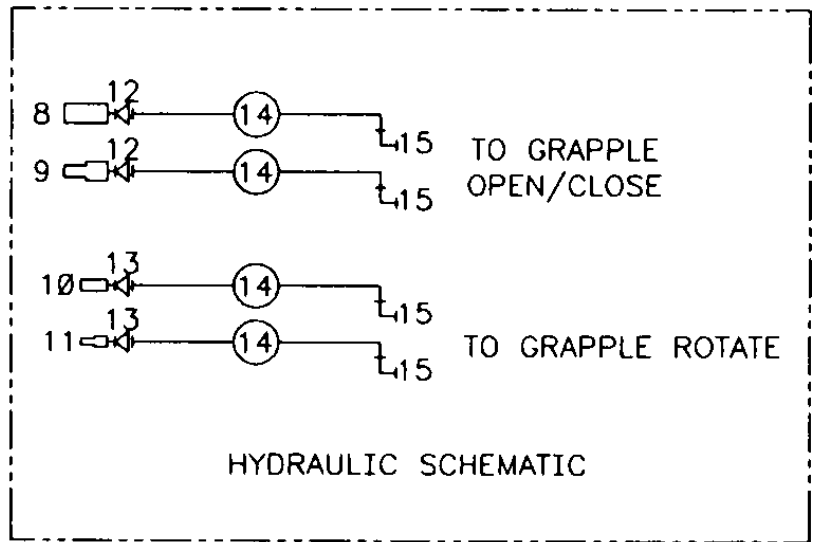
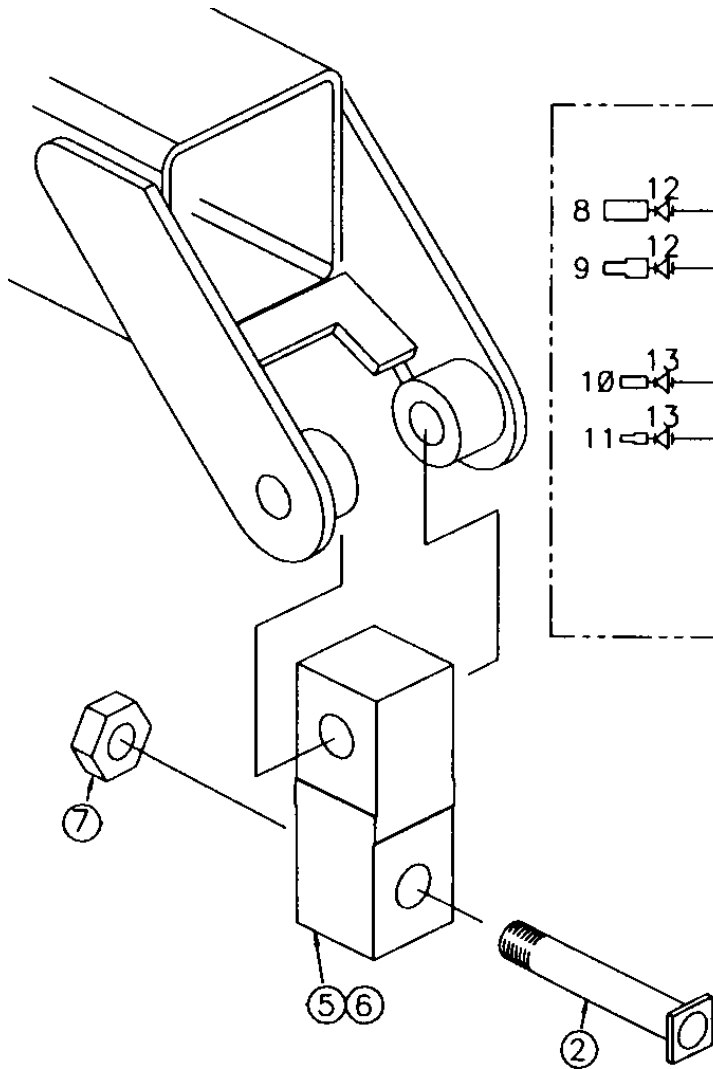

**GRAPPLE MOUNTING KIT-DAMPENED-S&L (51712053)**

ITEM	PART NO.	DESCRIPTION	QTY
1.	72063187	SPRING WASHER	2
2.	52710148	PIN	1
3.	70393323	FRICTION DISC	2
4.	52712628	PRESSURE PLATE	2
5.	60117864	SWIVEL LINK	1
6.	60104634	SLEEVE	2
7.	72062257	NUT 1 1/4-12 LOCK	1
8.	72532996	DISCONNECT COUPLER 1/2FPT	1
9.	72533118	DISCONNECT NIPPLE 1/2FPT	1
10.	72533101	DISCONNECT COUPLER 3/8FPT	1
11.	72533102	DISCONNECT NIPPLE 3/8FPT	1
12.	72053497	ADAPTER 1/2MPT #8MJIC	2
13.	72053670	ADAPTER 3/8MPT #8MJIC	2
14.	51710674	HOSE ASM 3/8X48 FJ	4
15.	72531420	ELBOW 3/8MPT #8MJIC 90°	4

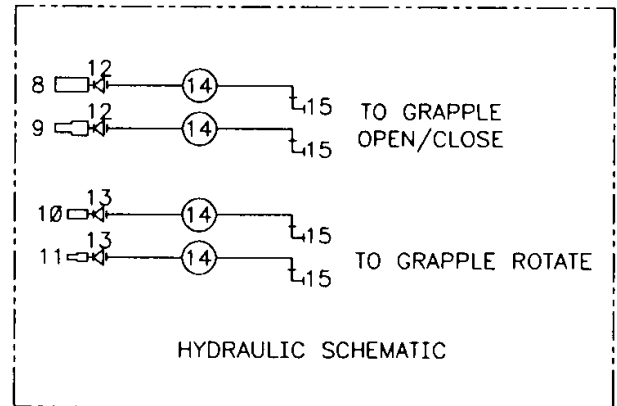
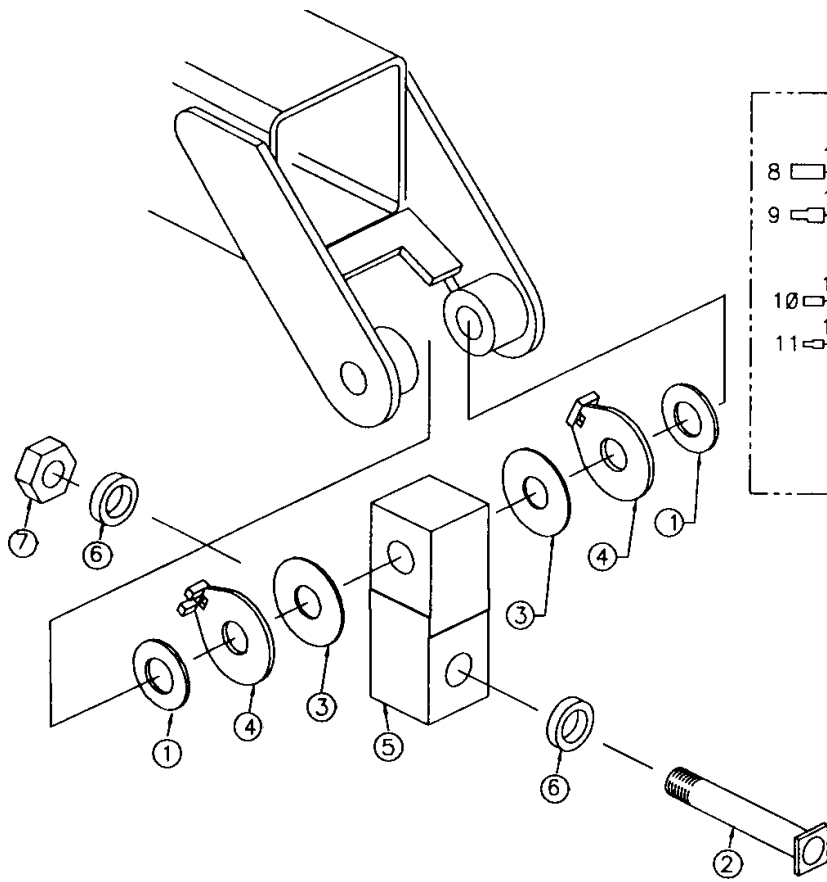

**2 GRAPPLE MOUNTING KIT-S&L  
(51712163)**

ITEM	PART NO.	DESCRIPTION	QTY
2.	60117980	BOLT 1 1/4-7X8-1/2 W/HOLE	1
3.	72066145	HAIR PIN 3/16	1
5.	60117238	SWIVEL LINK	1
6.	72053508	ZERK 1/8NPT	2
7.	72062011	NUT 1 1/4-7 HEX	1
8.	72532996	DISCONNECT COUPLER 1/2FPT	1
9.	72533118	DISCONNECT NIPPLE 1/2FPT	1
10.	72533101	DISCONNECT COUPLER 3/8FPT	1
11.	72533102	DISCONNECT NIPPLE 3/8FPT	1
12.	72053497	ADAPTER 1/2MPT #8MJIC	4
13.	72053670	ADAPTER 3/8MPT #8MJIC	4
14.	51710674	HOSE ASM 3/8X48 FJ	8
15.	72531420	ELBOW 3/8MPT #8MJIC 90°	8

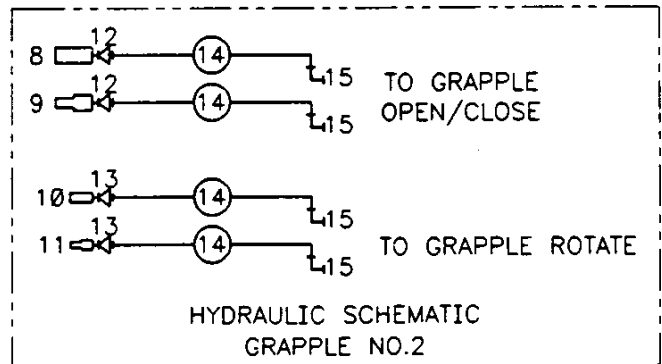
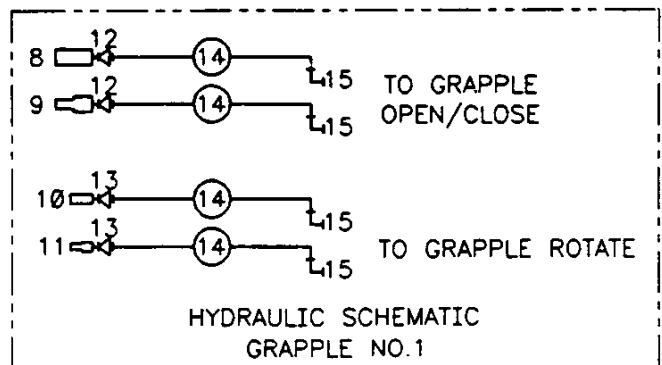
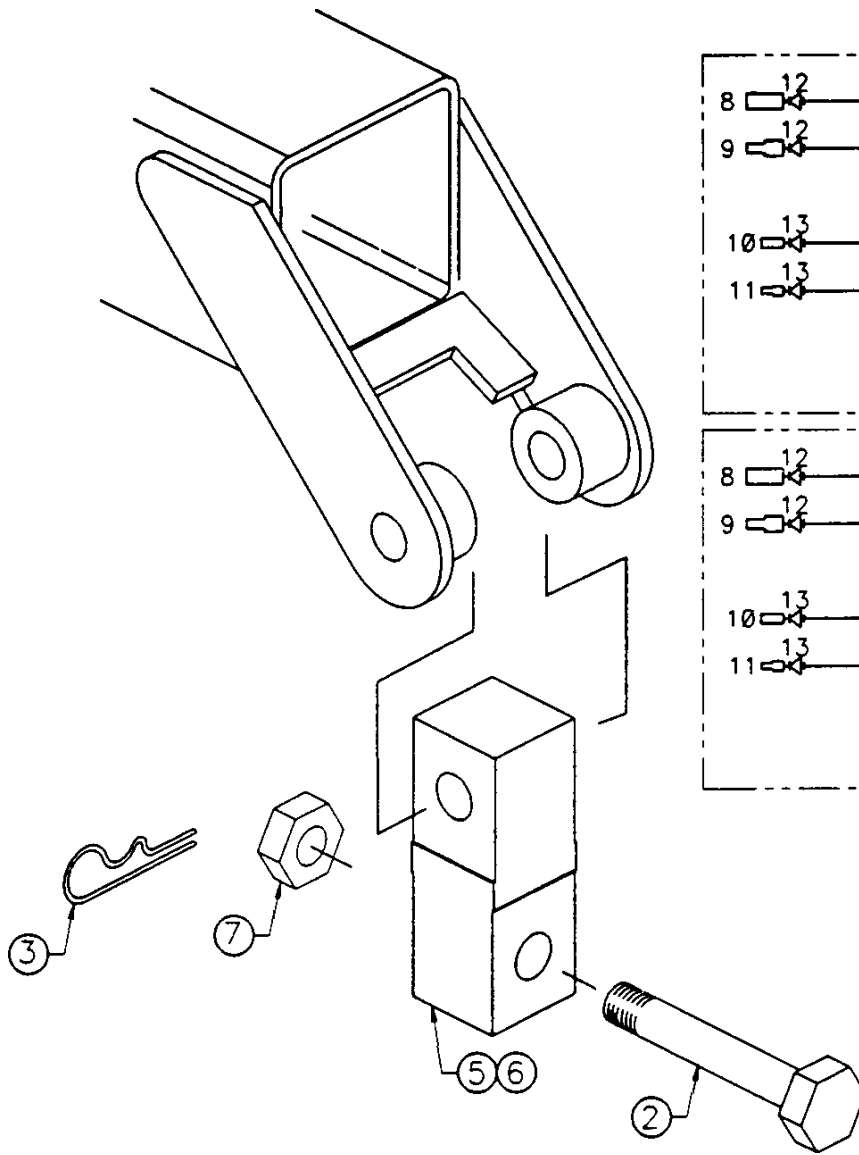



## SECTION 4. GENERAL REFERENCE

INSPECTION CHECKLIST .....	3
WIRE ROPE INSPECTION .....	7
HOOK INSPECTION .....	7
HOLDING VALVE INSPECTION .....	8
ANTI-TWO BLOCKING DEVICE INSPECTION .....	8
TORQUE DATA CHART-DOMESTIC .....	9
TORQUE DATA CHART-METRIC .....	10
TURNTABLE BEARING FASTENER TIGHTENING SEQUENCE .....	11
TURNTABLE BEARING INSPECTION FOR REPLACEMENT .....	12
LIMITED WARRANTY .....	14



<b>NOTICE</b>	
<b>The user of this form is responsible in determining that these inspections satisfy all applicable regulatory requirements</b>	
OWNER/COMPANY	
CONTACT PERSON	
CRANE MAKE & MODEL	
CRANE SERIAL NUMBER	
UNIT I.D. NUMBER	
LOCATION OF UNIT	

<i>Inspection Checklist</i>	
<b>CRANES</b>	
TYPE OF INSPECTION (check one) <input type="checkbox"/> DAILY (if deficiency found) <input type="checkbox"/> QUARTERLY <input type="checkbox"/> MONTHLY <input type="checkbox"/> ANNUAL	
DATE INSPECTED	
HOUR METER READING (if applicable)	
INSPECTED BY (print)	
SIGNATURE OF INSPECTOR	

REV. 6-18-99

1

**TYPE OF INSPECTION**  
**NOTES:**  
*Daily and monthly inspections are to be performed by a "designated" person, who has been selected or assigned by the employer or the employer's representative as being competent to perform specific duties.*  
*Quarterly and annual inspections are to be performed by a "qualified" person who, by possession of a recognized degree in an applicable field or certificate of professional standing, or who, by extensive knowledge, training and experience has successfully demonstrated the ability to solve or resolve problems related to the subject matter and work.*  
*One hour of normal crane operation assumes 20 complete cycles per hour. If operation exceeds 20 cycles per hour, inspection frequency should be increased accordingly.*  
*Consult Operator / Service Manual for additional inspection items, service bulletins and other information.*  
*Before inspecting and operating crane, crane must be set up away from power lines and leveled with outriggers fully extended.*

**DAILY (D):** Before each day of operation, those items designated with a **(D)** must be inspected. This inspection need not be recorded unless a deficiency (**X**) is found. If the end user chooses to record all daily inspections and those daily inspections include the monthly inspection requirements, there would be no need for a separate monthly inspection.

**MONTHLY (M):** Monthly inspections or 100 hours of normal operation (which ever comes first) includes all daily inspections plus items designated with an **(M)**. This inspection must be recorded.

**QUARTERLY (Q):** Every three to four months or 300 hours of normal operation (which ever comes first) includes all daily and monthly inspection items plus items designated with a **(Q)**. This inspection must be recorded.

**ANNUAL (A):** Each year or 1200 hours of normal operation (which ever comes first) includes all items on this form which encompasses daily, monthly and quarterly inspections plus those items designated by **(A)**. This inspection must be recorded.

FREQUENCY	ITEM	KEY	✓ = SATISFACTORY ✗ = DEFICIENCY (must be corrected prior to operation)	R = RECOMMENDATION (should be considered for corrective action) NA = NOT APPLICABLE	STATUS ✓, ✗, R, NA
			INSPECTION DESCRIPTION		
D	1	Labels	All load charts, safety & warning labels, & control labels are present and legible.		
D	2		Check all safety devices for proper operation.		
D	3	Controls	Control mechanisms for proper operation of all functions, leaks & cracks.		
D	4	Station	Control and operator's station for dirt, contamination by lubricants, & foreign materials.		
D	5	Hyd System	Hydraulic system (hoses, tubes & fittings) for leakage & proper oil level.		
D	6	Hook	Presence & proper operation of hook safety latches.		
D	7	Rope	Proper reeving of wire rope on sheaves & winch drum.		
D	8	Pins	Proper engagement of all connecting pins & pin retaining devices.		
D	9	General	Overall observation of crane for damaged or missing parts, cracked welds & presence of safety covers.		
D	10	Operation	During operation, observe crane for abnormal performance, unusual wear (loose pins, wire rope damage, etc.). If observed, discontinue use & determine cause & severity of hazard.		
D	11	Remote Ctrl	Operate remote control devices to check for proper operation.		
D	12	Electrical	Operate all lights, alarms, etc. to check for proper operation.		
D	13	Anti 2-Blocking	Operate anti 2-blocking device to check for proper operation.		
D	14		Other		
D	15		Other		

<i>Inspection Checklist</i>	CRANES	2
-----------------------------	--------	---

FREQUENCY	ITEM	KEY	✓ = SATISFACTORY ✗ = DEFICIENCY (must be corrected prior to operation)	R = RECOMMENDATION (should be considered for corrective action) NA = NOT APPLICABLE	STATUS
			INSPECTION DESCRIPTION	✓, ✗, R, NA	
M	16	Daily	All daily inspection items.		
M	17	Cylinders	Visual inspection of cylinders for leakage at rod, fittings & welds. Damage to rod & case.		
M	18	Valves	Holding valves for proper operation.		
M	19	Valves	Control valve for leaks at fittings & between sections.		
M	20	Valves	Control valve linkages for wear, smoothness of operation & tightness of fasteners.		
M	21	General	Bent, broken or significantly rusted/corroded parts.		
M	22	Electrical	Electrical systems for presence of dirt, moisture & frayed wires.		
M	23	Structure	All structural members for damage.		
M	24	Welds	All welds for breaks & cracks.		
M	25	Pins	All pins for proper installation & condition.		
M	26	Hardware	All bolts, fasteners & retaining rings for tightness, wear & corrosion		
M	27	Wear Pads	Presence of wear pads.		
M	28	Pump & Motor	Hydraulic pumps & motors for leakage at fittings, seals & between sections.		
M	29	PTO	Transmission/PTO for leakage, abnormal vibration & noise.		
M	30	Hyd Fluid	Quality of hydraulic fluid and for presence of water.		
M	31	Hyd Lines	Hoses & tubes for leakage, abrasion damage, blistering, cracking, deterioration, fitting leakage & secured properly.		
M	32	Hook	Load hook for abnormal throat distance, twist, wear & cracks.		
M	33	Rope	Condition of load line.		
M	34	Manual	Presence of operator's manuals with unit.		
M	35		Other		
Q	36	Daily	All daily inspection items.		
Q	37	Monthly	All monthly inspection items.		
Q	38		Condition of wear pads		
Q	39	Rotation Sys	Rotation bearing for proper torque of all accessible mounting bolts.		
Q	40	Hardware	Base mounting bolts for proper torque.		
Q	41	Structure	All structural members for deformation, cracks & corrosion.		
	42		● Base		
	43		● Outrigger beams & legs		
	44		● Mast		
	45		● Inner boom		
	46		● Outer boom		
	47		● Extension(s)		
	48		● Jib boom		
	49		● Jib extension(s)		
	50		● Other		
Q	51	Hardware	Pins, bearings, shafts, gears, rollers, & locking devices for wear, cracks, corrosion & distortion.		
	52		● Rotation bearing(s)		
	53		● Inner boom pivot pin(s) & retainer(s)		
	54		● Outer boom pivot pin(s) & retainer(s)		
	55		● Inner boom cylinder pin(s) & retainer(s)		
	56		● Outer boom cylinder pin(s) & retainer(s)		
	57		● Extension cylinder pin(s) & retainer(s)		
	58		● Jib boom pin(s) & retainer(s)		
	59		● Jib cylinder pin(s) & retainer(s)		
	60		● Jib extension cylinder pin(s) & retainer(s)		
	61		● Boom tip attachments		
	62		● Other		
Q	63	Hyd Lines	Hoses, fittings & tubing for proper routing, leakage, blistering, deformation & excessive abrasion.		
	64		● Pressure line(s) from pump to control valve		
	65		● Return line(s) from control valve to reservoir		
	66		● Suction line(s) from reservoir to pump		
	67		● Pressure line(s) from control valve to each function		
	68		● Load holding valve pipe(s) and hose(s)		
	69		● Other		





**WIRE ROPE INSPECTION**

Wire rope with any of the deficiencies shown below shall be removed and replaced immediately.

- A. Corrosion can be cause for replacement. Any development of corrosion must be noted and monitored closely.
- B. When there are either 3 broken wires in one strand or a total of six broken wires in all strands in any one rope lay.

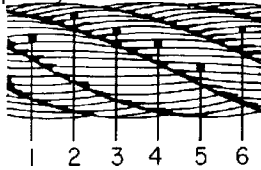

- C. When flat spots on the outer wires appear and those outside wires are less than 2/3 the thickness of the unworn outer wire.

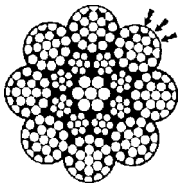

- D. When there is a decrease of diameter indicating a core failure.

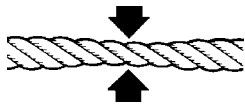

- E. When kinking, crushing, birdcaging or other distortion occurs.

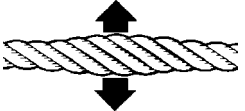

- F. When there is noticeable heat damage (discoloration) of the rope by any means.



- G. When the diameter is reduced from nominal size by 1/32" or more.



- H. If a broken wire protrudes or loops out from the core of the rope.

**HOOK INSPECTION**

Hooks having any of the listed deficiencies shall be removed from service unless a qualified person approves their continued use and initiates corrective action. Hooks approved for continued use shall be subjected to periodic inspection.

**A. DISTORTION****Bending/Twisting**

A bend or twist exceeding 10° from the plane of the unbent hook.

**Increased Throat Opening**

**HOOK WITHOUT LATCH:** An increase in throat opening exceeding 15% (Or as recommended by the manufacturer)

**HOOK WITH LATCH:** An increase of the dimension between a fully-opened latch and the tip section of the hook exceeding 8% (Or as recommended by the manufacturer)

**B. WEAR**

If wear exceeds 10% of the original sectional dimension. (Or as recommended by the manufacturer)

**C. CRACKS, NICKS, GOUGES**

Repair of cracks, nicks, and gouges shall be carried out by a designated person by grinding longitudinally, following the contour of the hook, provided that no dimension is reduced more than 10% of its original value. (Or as recommended by the manufacturer) (A qualified person may authorize continued use if the reduced area is not critical.)

**D. LATCH****Engagement, Damage & Malfunction**

If a latch becomes inoperative because of wear or deformation, and is required for the service involved, it shall be replaced or repaired before the hook is put back into service. If the latch fails to fully close the throat opening, the hook shall be removed from service or "moused" until repairs are made.

**E. HOOK ATTACHMENTS & SECURING MEANS**

If any indication of distortion, wear, cracks, nicks or gouges are present, unless a qualified person authorizes their use. (Or as recommended by the manufacturer)

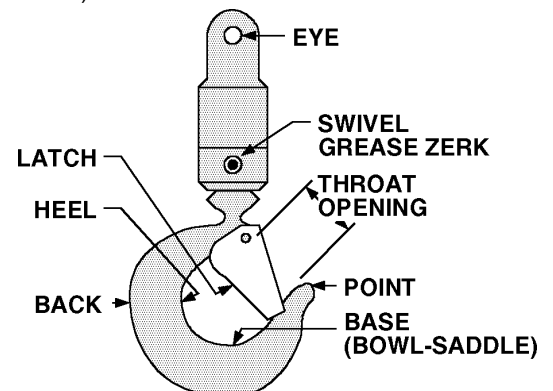

### HOLDING VALVE INSPECTION

The cylinders are equipped with holding valves that prevent sudden movement of the cylinder rods in the event of a hydraulic hose or other hydraulic component failure. The valve is checked in the following manner:

1. With a full rated load, extend the cylinder in question and kill the engine.
2. Operate the control valve to retract the cylinder. If the cylinder "creeps", replace the holding valve. If the cylinder does not "creep", the valve is serviceable.

### ANTI-TWO BLOCKING DEVICE INSPECTION

(See Vol. 1, Operation, Maintenance and Repair for a complete description)



The anti two block system should be checked daily as follows:

1. Examine flexible rod and weight to insure free unrestricted mechanical operation
2. Examine cord for damage, cuts or breaks. Grasp cord and pull to check operation of cord reel. The cord should retract on reel when released.
3. Start vehicle, engage PTO and slowly winch loadline up until anti-two block weight comes in contact with the hook end of the loadline cable. At the moment the weight is fully supported, a marked difference in winch operation should be noted. At this point, the winch up function should become very sluggish or non-functioning and have very little pull capability. Slowly increase truck engine speed while simultaneously actuating the winch up function. The winch characteristics should remain sluggish with little or no tensioning of the cable. If operation other than as described occurs, stop immediately and investigate. Failure to do so will risk damage to the cable or the crane. If all is well at this point, actuate the boom extend function slowly, and gradually increase to full actuation. Once again the function should be sluggish or non-existent with no tightening of the winch cable. If operation other than described occurs, stop immediately and reverse the function.

The final check involves actuating both the winch up and extend functions together and checking for proper operation of the anti two blocking circuit. Once again, start slowly and stop if it appears the cable is being tensioned.

If the anti two block function appears to be functioning normally, winch the cable down until the sensing weight swings free.

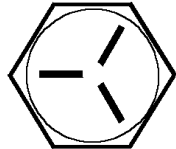
## COARSE THREAD BOLTS

SIZE (DIA.-TP)	BOLT DIA (INCHES)	TIGHTENING TORQUE			
					
		PLAIN (FT-LB)	PLATED (FT-LB)	PLAIN (FT-LB)	PLATED (FT-LB)
5/16-18	0.3125	17	13	25	18
3/8-16	0.3750	31	23	44	33
7/16-14	0.4375	49	37	70	52
1/2-13	0.5000	75	57	105	80
9/16-12	0.5625	110	82	155	115
5/8-11	0.6250	150	115	220	160
3/4-10	0.7500	265	200	375	280
7/8-9	0.8750	395	295	605	455
1-8	1.0000	590	445	910	680
1 1/8-7	1.1250	795	595	1290	965
1 1/4-7	1.2500	1120	840	1815	1360
1-3/8-6	1.3750	1470	1100	2380	1780
1 1/2-6	1.5000	1950	1460	3160	2370

When using the torque data in the charts above, the following rules should be observed.

1. Bolt manufacturer's particular specifications should be consulted when provided.
2. Flat washers of equal strength must be used.
3. All torque measurements are given in foot-pounds. To convert to inch-pounds, multiply by 12.
4. Torque values specified are for bolts with residual oils or no special lubricants applied. If special lubricants of high stress ability, such as Never-Seez compound graphite and oil, molybdenum disulphite, colloidal copper or white lead are applied, multiply the torque values in the charts by the factor .90. The use of Loctite does not affect the torque values listed above.
5. Torque values for socket-head capscrews are the same as for Grade 8 capscrews.

### WARNING





Anytime a gear-bearing bolt is removed, it must be replaced with a new bolt of the identical grade and size. Once a bolt has been torqued to 75% of its proof load and then removed, the torque coefficient may no longer be the same as when the bolt was new thus giving indeterminate clamp loads after torquing. Failure to replace gear-bearing bolts may result in bolt failure due to metal fatigue causing serious injury or DEATH.

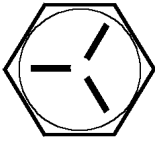

# TORQUE DATA CHART - DOMESTIC

## FINE THREAD BOLTS

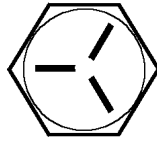
## COARSE THREAD BOLTS

SIZE (DIA-TPI)	BOLT DIA (INCHES)	TIGHTENING TORQUE				SIZE (DIA-TPI)	BOLT DIA (INCHES)	TIGHTENING TORQUE			
		 SAE J429 GRADE 5		 SAE J429 GRADE 8				 SAE J429 GRADE 5		 SAE J429 GRADE 8	
		PLAIN (FT-LB)	PLATED (FT-LB)	PLAIN (FT-LB)	PLATED (FT-LB)			PLAIN (FT-LB)	PLATED (FT-LB)	PLAIN (FT-LB)	PLATED (FT-LB)
5/16-24	0.3125	19	14	27	20	5/16-18	0.3125	17	13	25	18
3/8-24	0.3750	35	26	49	35	3/8-16	0.3750	31	23	44	33
7/16-20	0.4375	55	41	78	58	7/16-14	0.4375	49	37	70	52
1/2-20	0.5000	90	64	120	90	1/2-13	0.5000	75	57	105	80
9/16-18	0.5625	120	90	170	130	9/16-12	0.5625	110	82	155	115
5/8-18	0.6250	170	130	240	180	5/8-11	0.6250	150	115	220	160
3/4-16	0.7500	300	225	420	315	3/4-10	0.7500	265	200	375	280
7/8-11	0.8750	445	325	670	500	7/8-9	0.8750	395	295	605	455
1-12	1.0000	645	485	995	745	1-8	1.0000	590	445	910	680
1 1/8-12	1.1250	890	670	1445	1085	1 1/8-7	1.1250	795	595	1290	965
1 1/4-12	1.2500	1240	930	2010	1510	1 1/4-7	1.2500	1120	840	1815	1360
1-3/8-12	1.3750	1675	1255	2710	2035	1-3/8-6	1.3750	1470	1100	2380	1780
1 1/2-12	1.5000	2195	1645	3560	2670	1 1/2-6	1.5000	1950	1460	3160	2370

When using the torque data in the charts above, the following rules should be observed.



1. Bolt manufacturer's particular specifications should be consulted when provided.
2. Flat washers of equal strength must be used.
3. All torque measurements are given in foot-pounds. To convert to inch-pounds, multiply by 12.
4. Torque values specified are for bolts with residual oils or no special lubricants applied. If special lubricants of high stress ability, such as Never-Seez compound graphite and oil, molybdenum disulphite, colloidal copper or white lead are applied, multiply the torque values in the charts by the factor .90. The use of Loctite does not affect the torque values listed above.
5. Torque values for socket-head capscrews are the same as for Grade 8 capscrews.

### WARNING



Anytime a gear-bearing bolt is removed, it must be replaced with a new bolt of the identical grade and size. Once a bolt has been torqued to 75% of its proof load and then removed, the torque coefficient may no longer be the same as when the bolt was new thus giving indeterminate clamp loads after torquing. Failure to replace gear-bearing bolts may result in bolt failure due to metal fatigue causing serious injury or DEATH.

# TORQUE DATA CHART - METRIC

## FINE THREAD BOLTS

SIZE (DIA-TPI)	BOLT DIA (INCHES)	TIGHTENING TORQUE			
					
		PLAIN (KG-M)	PLATED (KG-M)	PLAIN (KG-M)	PLATED (KG-M)
5/16-24	0.3125	3	2	4	3
3/8-24	0.3750	5	4	7	5
7/16-20	0.4375	8	6	11	8
1/2-20	0.5000	12	9	17	12
9/16-18	0.5625	17	12	24	18
5/8-18	0.6250	24	18	33	25
3/4-16	0.7500	41	31	58	44
7/8-11	0.8750	62	45	93	69
1-12	1.0000	89	67	138	103
1 1/8-12	1.1250	123	93	200	150
1 1/4-12	1.2500	171	129	278	209
1-3/8-12	1.3750	232	174	375	281
1 1/2-12	1.5000	304	228	492	369

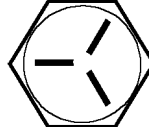
## COARSE THREAD BOLTS

SIZE (DIA-TPI)	BOLT DIA (INCHES)	TIGHTENING TORQUE			
					
		PLAIN (KG-M)	PLATED (KG-M)	PLAIN (KG-M)	PLATED (KG-M)
5/16-18	0.3125	2	2	3	2
3/8-16	0.3750	4	3	6	5
7/16-14	0.4375	7	5	10	7
1/2-13	0.5000	10	8	15	11
9/16-12	0.5625	15	11	21	16
5/8-11	0.6250	21	16	30	22
3/4-10	0.7500	37	28	52	39
7/8-9	0.8750	55	41	84	63
1-8	1.0000	82	62	126	94
1 1/8-7	1.1250	110	82	178	133
1 1/4-7	1.2500	155	116	251	188
1-3/8-6	1.3750	203	152	329	246
1 1/2-6	1.5000	270	210	438	328

When using the torque data in the charts above, the following rules should be observed.

1. Bolt manufacturer's particular specifications should be consulted when provided.
2. Flat washers of equal strength must be used.
3. All torque measurements are given in kilogram-meters.
4. Torque values specified are for bolts with residual oils or no special lubricants applied. If special lubricants of high stress ability, such as Never-Seez compound graphite and oil, molybdenum disulphite, colloidal copper or white lead are applied, multiply the torque values in the charts by the factor .90. The use of Loctite does not affect the torque values listed above.
5. Torque values for socket-head capscrews are the same as for Grade 8 capscrews.

### WARNING

Anytime a gear-bearing bolt is removed, it must be replaced with a new bolt of the identical grade and size. Once a bolt has been torqued to 75% of its proof load and then removed, the torque coefficient may no longer be the same as when the bolt was new thus giving indeterminate clamp loads after torquing. Failure to replace gear-bearing bolts may result in bolt failure due to metal fatigue causing serious injury or DEATH.

## TURNTABLE BEARING FASTENER TIGHTENING SEQUENCE

Refer to the diagram below for proper tightening/torquing sequence of the turntable bearing to the crane base and crane mast. The total quantity of cap screws varies dependent on crane model.

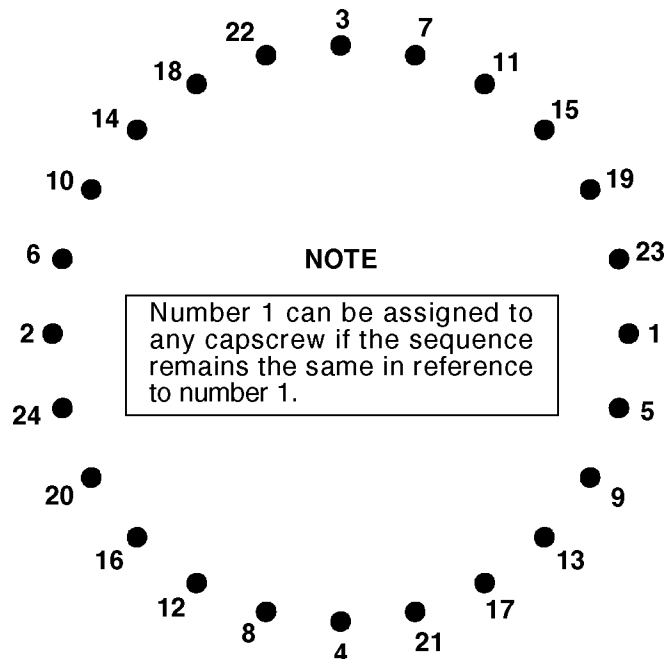

### TIGHTENING PROCEDURE:

1. Refer to the Torque Data Chart to determine the proper torque value to apply to the size of capscrew used.
2. Follow the tightening sequence shown in the diagram. Note that the quantity of capscrews may differ from the diagram, but the sequence must follow the criss-cross pattern as shown in the diagram.
3. Torque all capscrews to approximately 40% of the specified torque value, by following the sequence.  
(EXAMPLE:  $.40 \times 265 \text{ FT-LBS} = 106 \text{ FT-LBS}$ )  
(EXAMPLE-METRIC:  $.40 \times 36 \text{ KG-M} = 14.4 \text{ KG-M}$ )
4. Repeat Step 3, but torquing all capscrews to 75% of the specified torque value. Continue to follow the tightening sequence.  
(EXAMPLE:  $.75 \times 265 \text{ FT-LBS} = 199 \text{ FT-LBS}$ )  
(EXAMPLE-METRIC:  $.75 \times 36 \text{ KG-M} = 27 \text{ KG-M}$ )
5. Using the proper sequence, torque all capscrews to the listed torque value as determined from the Torque Data Chart.

# TURNTABLE BEARING INSPECTION FOR REPLACEMENT

Before a bearing is removed from a crane for inspection, one of the following conditions should be evident:

1. Metal particles present in the bearing lubricant.
2. Increased drive power required to rotate the crane.
3. Noise emitting from the bearing during crane rotation.
4. Rough crane rotation.
5. Uneven or excessive wear between the pinion gear and turntable gear.

If none of the above conditions exists, the bearing is functioning properly and need not be replaced. But, if one or more of the above conditions exists, inspection may be required. Limits are measured in "TILT" which is dependent on the internal clearances of the bearing. TILT is the most practical determination of a bearing's internal clearance once mounted on a crane.

Periodic readings indicating a steady increase in TILT may be an indicator of bearing wear. Note that a bearing found to have no raceway cracks or other structural irregularities should be reassembled and returned to service.

## TEST PROCEDURE

### STEP 1.

With the crane horizontal and fully extended, measure between the top and bottom mounting surfaces of the turntable bearing (A1), using a dial indicator for accuracy.

### STEP 2.

Reverse the load by applying minimal downward pressure on the boom while the boom is in the boom support or on a solid surface. Again measure A2.

### STEP 3.

Subtract A1 from A2 to determine tilt and compare the result with the accompanying chart.

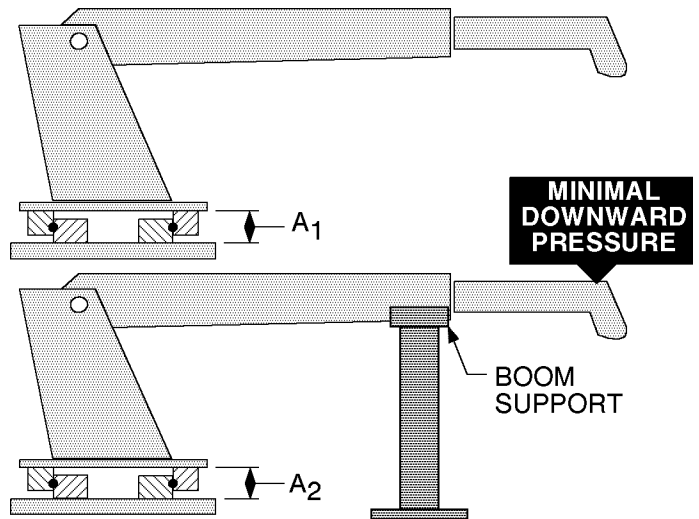

COMPARISON CHART - MODEL TO MEASURED TILT DIMENSION					
<p><b>NOTE</b> THE FIGURES LISTED IN THIS CHART ARE SERVICE GUIDELINES AND DO NOT, IN THEMSELVES, REQUIRE THAT THE BEARING BE INSPECTED.</p> <p>IF THERE IS REASON TO SUSPECT AN EXCESS OF BEARING WEAR AND THE MEASURED TILT DIMENSION EXCEEDS THE DIMENSION LISTED, REMOVE THE BEARING FOR INSPECTION.</p>	<p><b>IMT CRANE, LOADER OR TIREHAND MODEL</b></p>	1007	5200	16000	9800
		1014	5200R	32018	12916
		1014A	5217	32030	13031
	2015	5800	T30	13034	
	2020	7020	T40	14000	
	2109	7025		15000	
	3000	7200		18000	
	3016	7415		20017	
	3816	9000		H1200	
	3020	TH10 BODY ROT'N		H1200RR	
	425	TH14 BODY ROT'N		T50	
	4300			TH2551B BODY ROT'N	
	5016			TH2557B BODY ROT'N	
	6016			TH2557A BODY ROT'N	
	TH7 BODY ROT'N				
	TH1449 BODY ROT'N				
	TH15B CLAMP				
	TH2551B CLAMP				
	TH2557A CLAMP				
	<b>BALL DIA. (REF)</b>	.875" (22mm)	1.00" (25mm)	1.18"-1.25" (30-32mm)	1.75" (44mm)
	<b>TILT DIM. (A<sub>1</sub>-A<sub>2</sub>)</b>	.060" (1.524mm)	.070" (1.778mm)	.075" (1.905mm)	.090" (2.286mm)

The information within this manual has been compiled and checked but errors do occur. To provide our customers with a method of communicating those errors we have provided the Manual Change Request form below. In addition to error reporting, you are encouraged to suggest changes or additions to the manual which would be of benefit to you. We cannot guarantee that these additions will be made but we do promise to consider them. When completing the form, please write or print clearly. Submit a copy of the completed form to the address listed below.

## MANUAL CHANGE REQUEST

DATE	PRODUCT MANUAL	MANUAL PART NO.
SUBMITTED BY		
COMPANY		
ADDRESS		
CITY, STATE, ZIP		
TELEPHONE		

ERROR FOUND

LOCATION OF ERROR (page no.): \_\_\_\_\_

DESCRIPTION OF ERROR: \_\_\_\_\_

---

---

---

---

---

---

---

---

---

---

---

---

REQUEST FOR ADDITION TO MANUAL

DESCRIPTION OF ADDITION: \_\_\_\_\_

---

---

---

REASON FOR ADDITION: \_\_\_\_\_

---

---

---

MAIL TO: IOWA MOLD TOOLING Co., Inc.  
 Box 189,  
 Garner IA 50438-0189  
 ATTN: Technical Publications

## LIMITED WARRANTY

**WARRANTY COVERAGE** - Products manufactured by Iowa Mold Tooling Co., Inc. (IMT) are warranted to be free from defects in material and workmanship, under proper use, application and maintenance in accordance with IMT's written recommendations, instructions and specifications as follows:

1. Ninety (90) days; labor on IMT workmanship from the date of shipment to the end user.
2. One (1) year; original IMT parts from the date of shipment to the end user.

IMT's obligation under this warranty is limited to, and the sole remedy for any such defect shall be the repair or replacement (at IMT's option) of unaltered parts returned to IMT, freight prepaid, and proven to have such defect, provided such defect occurs within the above stated warranty period and is reported within fourteen (14) days of its occurrence.

**IMPLIED WARRANTY EXCLUDED** - This is the only authorized IMT warranty and is in lieu of all other express or implied warranties or representations, including any implied warranties of merchantability or fitness for any particular purpose or of any other obligations on the part of IMT.

**ITEMS EXCLUDED** - The manufacturer gives no warranty on any components purchased by the manufacturer, and such components as are covered only by the warranties of their respective manufacturers.

**WARRANTY CLAIMS** - Warranty claims must be submitted and shall be processed in accordance with IMT's established warranty claim procedure.

**WARRANTY SERVICE** - Warranty service will be performed by any IMT distributor authorized to sell new IMT products of the type involved or by any IMT Service Center authorized to service the type of product involved or by IMT in the event of direct sales made by IMT. At the time of requesting warranty service, the purchaser must present evidence of the date of delivery of the product. The purchaser shall pay any premium for overtime labor requested by the purchaser, any charge for making service calls and for transporting the equipment to the place where warranty work is performed.

**WARRANTY VOIDED** - All obligations of IMT under this warranty shall be terminated: (1) if service other than normal maintenance or normal replacement of service items is performed by someone other than an authorized IMT dealer, (2) if product is modified or altered in ways not approved by IMT.

**PURCHASER'S RESPONSIBILITY** - This warranty covers only defective material and workmanship. It does not cover depreciation or damage caused by normal wear, accident, improper protection in storage, or improper use. The purchaser has the obligation of performing the care and maintenance duties discussed in IMT's written recommendations, instructions and specifications. Any damage which results because of purchaser's failure to perform such duties shall not be covered by this warranty. The cost of normal maintenance and normal replacement of service items such as filters, belts, etc. shall be paid by the purchaser.

**CONSEQUENTIAL DAMAGES** - The only remedies the purchaser has in connection with the breach or performance of any warranty on IMT products are those set forth above. In no event will the dealer, IMT or any company affiliated with IMT, be liable for business interruptions, loss of sales and/or profits, rental or substitute equipment, costs of delay or for any other special, indirect, incidental or consequential losses, costs or damages.

**REPRESENTATIONS EXCLUDED** - IMT products are subject to no expressed, implied or statutory warranty other than herein set forth, and no agent, representative or distributor of the manufacturer has any authority to alter the terms of this warranty in any way whatsoever or to make any representations or promises, express or implied, as to the quality or performance of IMT products other than those set forth above.

**CHANGE IN DESIGN** - IMT reserves the right to make changes in design or improvements upon its products without imposing any obligation upon itself to install the same upon its products theretofore manufactured.

Effective January, 1985

This parts manual is provided to the user to assist in servicing the equipment. It is the property of Iowa Mold Tooling Co., Inc and, as such, may not be reproduced either whole or in part, whether by chemical, electrostatic, mechanical or photographic means without the expressed written permission of an officer of Iowa Mold Tooling Co., Inc. One manual is provided with each piece of new equipment and additional manuals may be obtained at a nominal price.



**IOWA MOLD TOOLING CO., INC.**  
 BOX 189, GARNER, IA 50438-0189  
 TEL: 515-923-3711  
 TECHNICAL SUPPORT FAX: 515-923-2424