Manual # 99904699

10/65 Technical Specifications

Revision Date 20111213



IOWA MOLD TOOLING CO., INC.

PO Box 189

Garner, IA 50438

Tel: 641-923-3711 FAX: 641-923-2424

Website: <http://www.imt.com>

Copyright © 2011 Iowa Mold Tooling Co., Inc.
All rights reserved

No part of this publication may be reproduced, stored in a retrieval system, or transmitted in any form or by any means, electronic, mechanical, photocopying, recording or otherwise without the prior written permission of Iowa Mold Tooling Co., Inc.

Iowa Mold Tooling Co., Inc. is an Oshkosh Corporation company.

Printed on 13 December, 2011

Contents

Revisions	ii
Technical Data and Charts	3
10/65 Specifications.....	3
10/65 Pressure Settings.....	5
10/65 K1 Capacity Chart	6
10/65 K2 Capacity Chart	7
10/65 K3 Capacity Chart	8
10/65 K4 Capacity Chart	9
10/65 Geometric Configuration	10
10/65 Hydraulic Diagram	11

Revisions

DATE	LOCATION	DESCRIPTION

CHAPTER 1

Technical Data and Charts

In This Chapter

10/65 Specifications	3
10/65 Pressure Settings	4
10/65 K1 Capacity Chart	6
10/65 K2 Capacity Chart	7
10/65 K3 Capacity Chart	8
10/65 K4 Capacity Chart	9
10/65 Geometric Configuration	10
10/65 Hydraulic Diagram.....	11

10/65 Specifications

10/65	1-HYDRAULIC	2-HYDRAULIC	3-HYDRAULIC	4-HYDRAULIC
Crane Rating*	65,095 ft-lb (9.0 tm)	63,650 ft-lb (8.8 tm)	60,755 ft-lb (8.4 tm)	57,865 ft-lb (8.0 tm)
Maximum Horizontal Reach	18' 8" (5.7 m)	24' 11" (7.6 m)	30' 10" (9.4 m)	37' 1" (11.3 m)
Maximum Vertical Reach	25' 3" (7.7 m)	31' 2" (9.5 m)	36' 9" (11.2 m)	42' 8" (13.0 m)
Maximum Capacity	7165 lb (3250 kg)	6945 lb (3150 kg)	6770 lb (3070 kg)	6615 lb (3000 kg)
Max Cap @ Max Reach	3585 lb (1625 kg)	2590 lb (1175 kg)	1920 lb (870 kg)	1435 lb (650 kg)
Crane Weight **	2315 lb (1050 kg)	2515 lb (1140 kg)	2710 lb (1230 kg)	2890 lb (1310 kg)
Hook Approach				
Vertical	8' 10" (2.69 m)	8' 6" (2.60 m)	8' 3" (2.52 m)	8' 0" (2.44 m)
Horizontal	2' 9" (0.84 m)	2' 11" (0.89 m)	3' 1" (0.94 m)	3' 3" (1.0 m)
Center of Gravity - Stored				
Vertical	1' 10" (555 mm)	1' 10" (560 mm)	1' 10" (570 mm)	1' 11" (580 mm)
Horizontal (C/L RotTo Bridge)	6.7" (170 mm)	6.7" (170 mm)	6.7" (170 mm)	6.7" (170 mm)

* Crane rating (ft-lb) is the rated load (lb) multiplied by the respective distance (ft) from centerline of rotation with all extensions retracted and the inner and outer booms in a horizontal position, per ANSI B30.22. ** Crane weight does not include stabilizers.

10/65 SPECIFICATIONS	
Stabilizer Pad Diameter	6.3" (160 mm)
Crane Storage Height	7' 0" (2130 mm)
Mounting Space ***	2' 3" (680 mm)
Rotational Torque	10,055 ft-lb (1390 kg-m)
Rotation	400°
Optimum Pump Performance	9 gpm (35 lpm)
System Pressure	4640 psi (320 bar)
Oil Reservoir Capacity	11 gal (42 l)
Stabilizer Extension Span	
Standard (manual out /hydraulic down)	15' 3" (4650 mm)
Weight	380 lb (173 kg)
Option (hydraulic out / hydraulic down)	18' 10" (5750 mm)
Weight	540 lb (245 kg)
*** Maximum swing clearance radius required is 23" (575 mm) at 7'-7" (2320 mm) from top of chassis frame.	

MINIMUM CHASSIS SPECIFICATIONS	
Front Axle Rating (GAWR)	9,000 lb (4080 kg)
Rear Axle Rating (GAWR)	17,000 lb (7710 kg)
Resistance To Bending Moment	960,000 in-lb (110,605 kg-m)

10/65 Pressure Settings

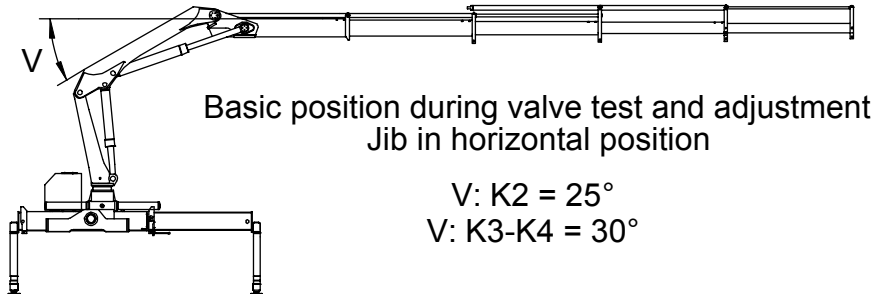

Working pressure on main-relief valve & port-relief valves			
Function		Port	
Main-relief valve			4640 psi (320 bar)
Stabilizer legs / grab / rotator	up	A-port	2175 psi (150 bar)
	down	B	2175 psi (150 bar)
		A	2175 psi (150 bar)
		B	2175 psi (150 bar)
Extension cylinders	extend	A	P
	retract	B	P
Jib cylinder	up	A	3990 psi (275 bar)
	down	B	2540 psi (175 bar)
Boom cylinder	down	A	1815 psi (125 bar)
	up	B	4715 psi (325 bar)
Slewing system	right	A	2175 psi (150 bar)
	left	B	2175 psi (150 bar)
Separate stabilizer valve			2175 psi (150 bar)

Opening pressure on load-holding valves	
Boom cylinder	5005 psi (345 bar)
Jib cylinder	3990 psi (275 bar)
Extension cylinder C1-V1 (retract B)	6235 psi (430 bar)
Extension cylinder C2-V2 (extend A)	3045 psi (210 bar)
External relief valve	
Pressure setting for load moment limitation	
LMB	4455 psi (307 bar)
Maximum pump performance	
Pump performance (K2)	9.2 gpm (35 l/min)
Pump performance (K3-K4)	7.9 gpm (30 l/min)

10/65 K1 Capacity Chart

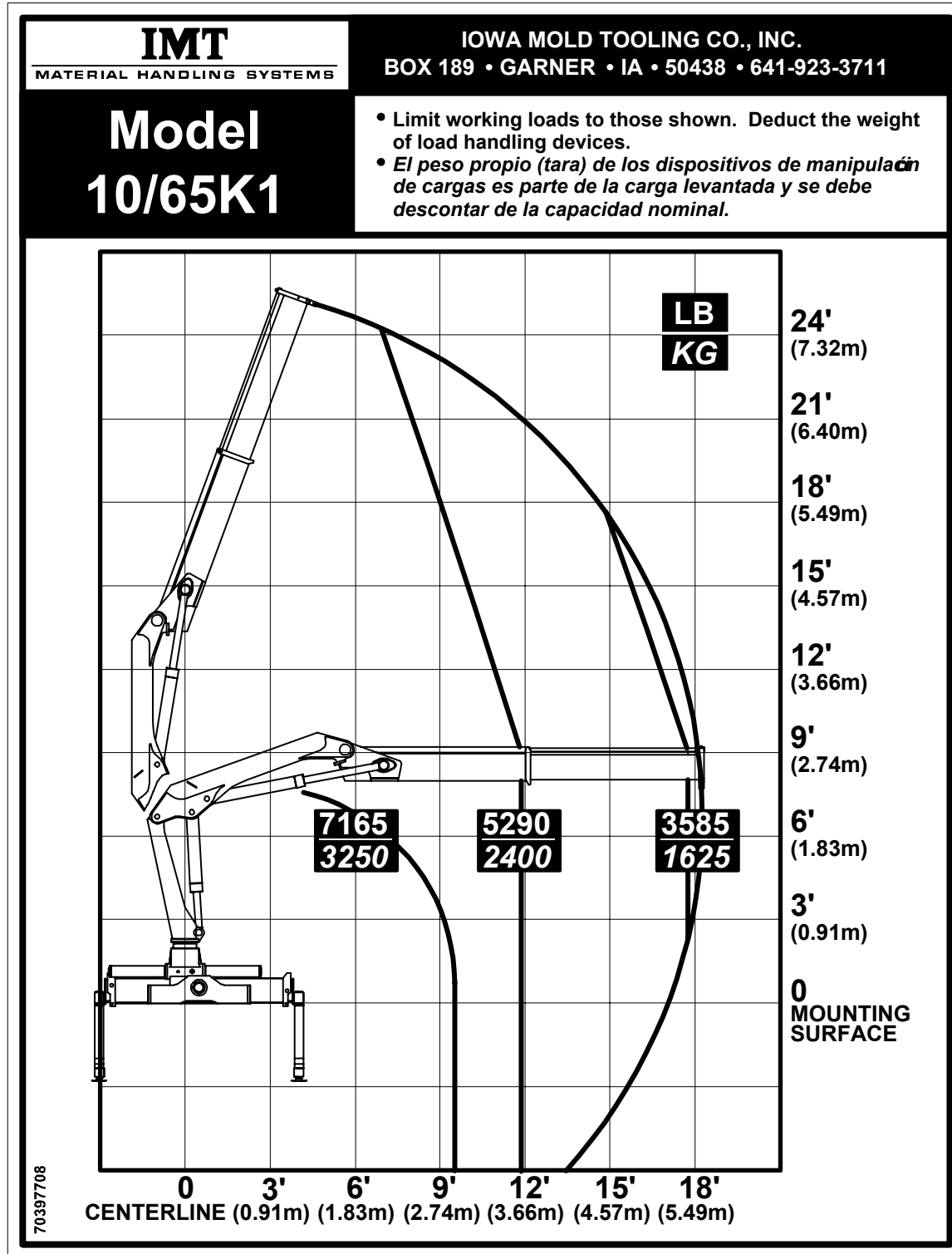

10/65 K2 Capacity Chart

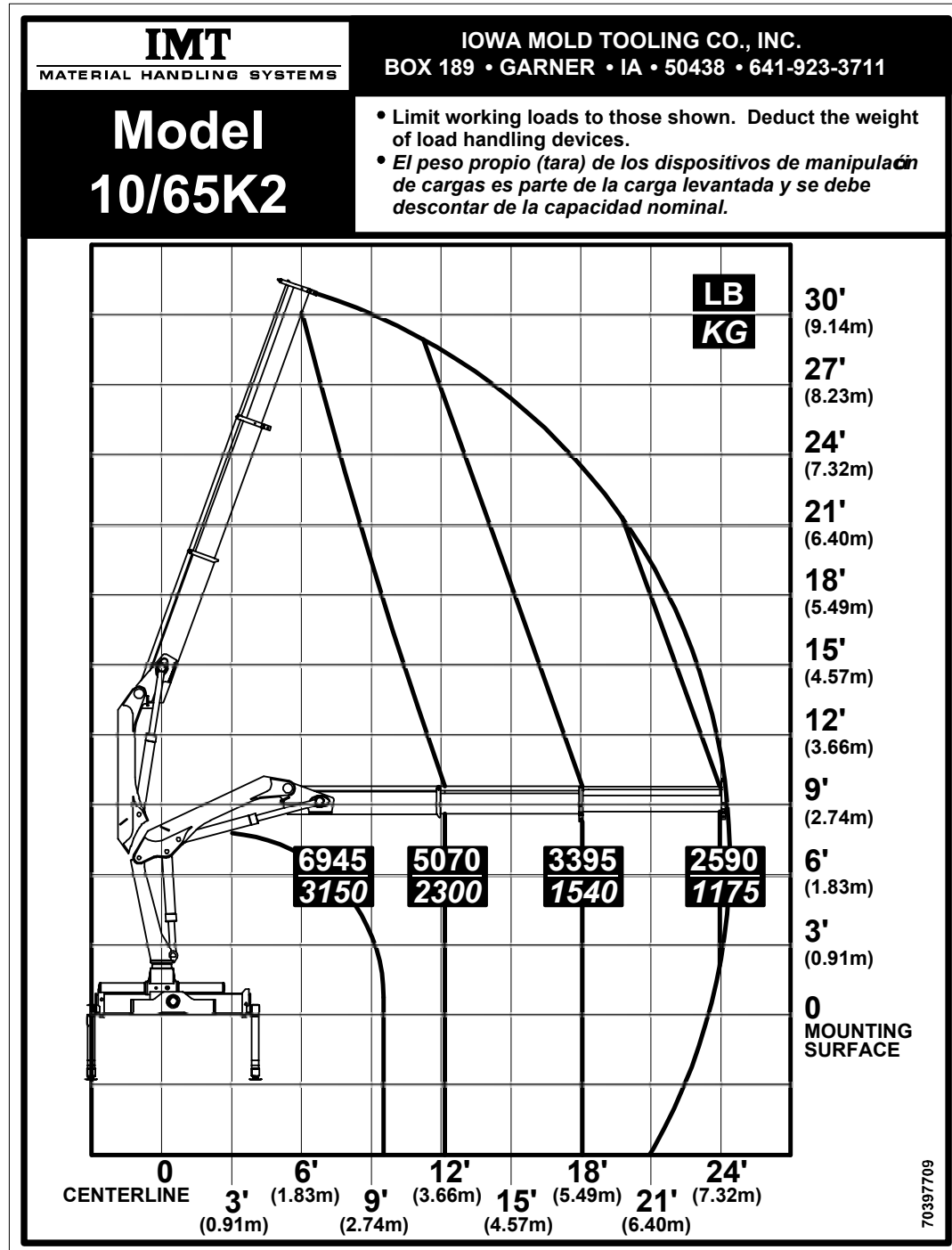

10/65 K3 Capacity Chart

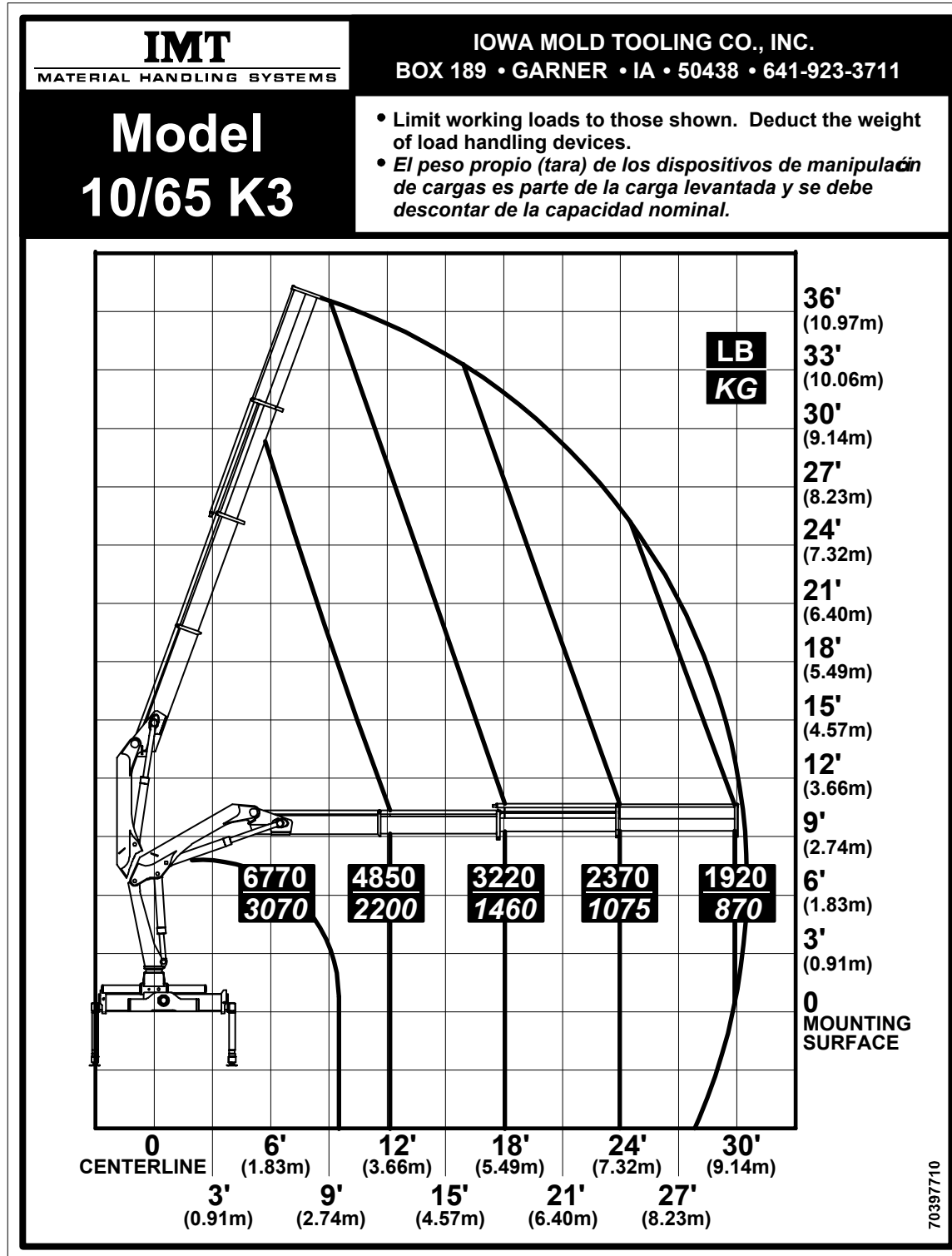

10/65 K4 Capacity Chart

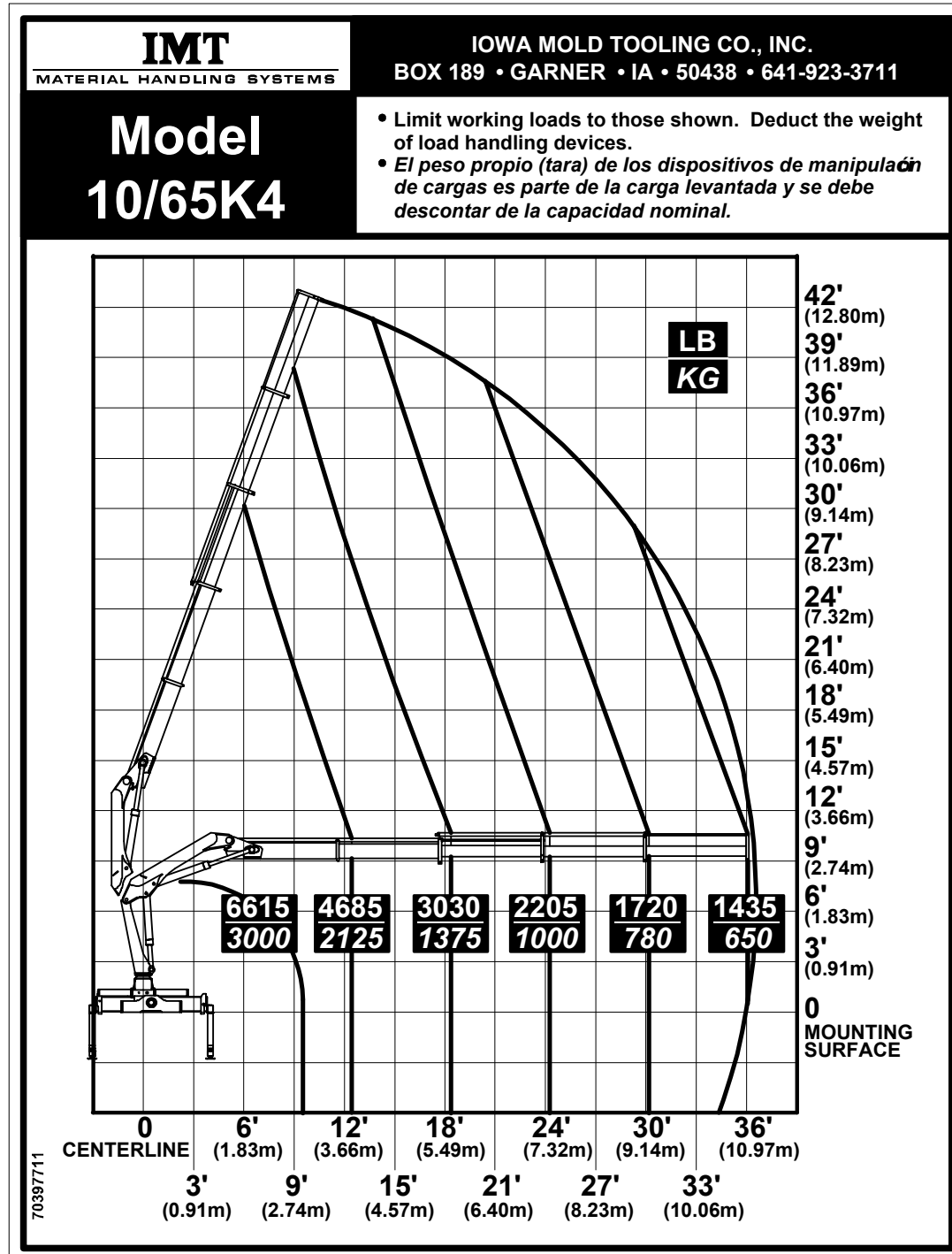

10/65 Geometric Configuration

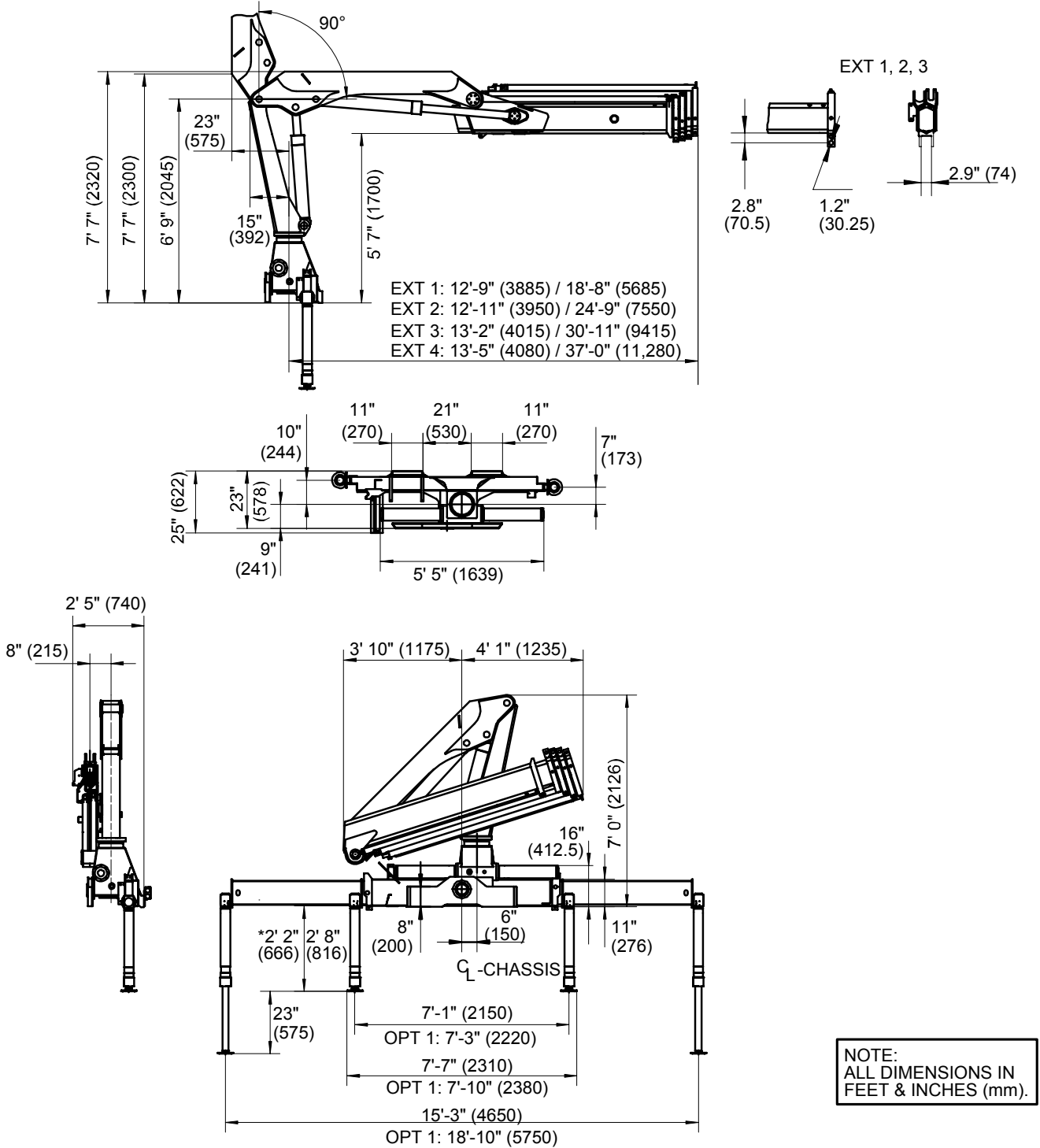

10/65 Hydraulic Diagram

