



PART & SPECIFICATIONS

Model 0614 Crane

IOWA MOLD TOOLING CO., INC.

BOX 189 GARNER, IA 50438
515-923-3711

MANUAL PART NO. 99900467

TABLE OF CONTENTS

Paragraph	Title	Page
SECTION 1. SPECIFICATIONS		
SECTION 2. CRANE DESCRIPTION		
2-1.	General	2-1
2-2.	Base	2-1
2-3.	Mast	2-1
2-4.	Main Boom	2-1
2-5.	Secondary Boom	2-1
2-6.	Extension Boom	2-1
2-7.	Controls	2-1
2-8.	Hydraulic Kit	2-1
SECTION 3. INSTALLATION		
3-1.	General	3-1
SECTION 4. PARTS LIST		
4-1.	General	4-1
4-2.	Crane Identification	4-1
4-3.	Cylinder Identification	4-1
4-4.	Weldment Identification	4-2
4-5.	Ordering Repair Parts	4-2
LIST OF ILLUSTRATIONS		
Figure	Title	Page
A-1.	Geometric Configuration	1-2
A-2.	Capacity Chart	1-3
B-1.	0614 Crane Group	2-1
C-1.	Crane Installation	3-1
D-1.	Crane Identification Plate	4-1
D-2.	Cylinder Identification Plate	4-1
D-3.	Location of Stamped Cylinder Number	4-2
D-4.	Location of Stamped Weldment Number	4-2
D-5.	Base and Outriggers (Part Number 41703791)	4-3
D-6.	Mast (Part Number 41703792)	4-4
D-7.	Main Boom (Part Number 41703793)	4-4
D-8.	Main and Secondary Cylinder (Part Number 3B129082)	4-5
D-9.	Counter-Balance Holding Valve	4-5
D-10.	Secondary and Extension Boom (Part Number 41703794)	4-6
D-11.	Installation Kit (Part Number 93703797)	4-7
D-12.	Remote Control Kit - Sheet 1 of 2 (Part Number 90703798)	4-8
D-13.	Remote Control Kit - Sheet 2 of 2 (Part Number 90703798)	4-9
D-14.	Hydraulic Kit (Part Number 91703799)	4-10

This volume deals with information applicable to your particular crane. For operating, maintenance and repair instructions, refer to Volume 1, Maintenance and Repair. Volume 1 contains the following information:

- SECTION 1. OPERATION
- SECTION 2. MAINTENANCE
- SECTION 3. REPAIR
- SECTION 4. INSPECTION & TEST REPORT
- SECTION 5. INSTALLATION - CHASSIS PREPARATION
- SECTION 6. APPENDIX

We recommend that Volume 2, Parts and Specifications be kept in a safe place in the office.

This manual is provided to assist you with ordering parts for your IMT truck-mounted articulating crane. It also contains additional instructions regarding your particular installation.

Three means are used throughout this manual to gain the attention of personnel. They are NOTES, CAUTIONS and WARNINGS and are defined as follows:

NOTE

A NOTE is used to either convey additional information or to provide further emphasis for a previous point.

CAUTION

A CAUTION is used when there is the strong possibility of damage to the equipment or premature equipment failure.

WARNING

A WARNING is used when there is the potential for personal injury or death.

It is the user's responsibility to maintain and operate this unit in a manner that will result in the safest working conditions possible.

In addition, it is also the user's responsibility to be aware of existing Federal, State and Local codes and regulations regarding the safe use and maintenance of this unit. Listed below are two publications that the user should thoroughly read and understand.

ANSI B30.15

MOBILE HYDRAULIC CRANES

The American Society of Mechanical Engineers
United Engineering Center
345 East 47th Street
New York, NY 10017

USAS B30.5

CRAWLER, LOCOMOTIVE AND TRUCK CRANES

The American Society of Mechanical Engineers
United Engineering Center
345 East 47th Street
New York, NY 10017

Warranty of this unit will be void on any part of the unit subjected to misuse due to overloading, abuse, lack of maintenance or unauthorized modifications. No warranty - verbal, written or implied - other than the official published IMT new machinery and equipment warranty will be valid with this unit.

Treat this equipment with respect and service it regularly. These two things can add up to a safer working environment and longer equipment life.

Section 1. SPECIFICATIONS

GENERAL

Reach (from centerline of rotation)	(4.27 m)	14'-0"
Extension (manual)	(101.6 cm)	40"
Lifting Height (based on 27" truck frame)	(6.53 m)	21'-5"
Weight of Crane	(431 kg)	950 lbs.
Outrigger Span	(2.24 m)	7'-4"
Optimum Pump Capacity	(5.7 liters/min.)	1-1/2 US GPM
Oil Reservoir Capacity	(15.14 liters)	4 US Gal.
*Mounting Space Required	(48.3 cm)	19"
Storage Height (based on 27" truck frame)	(2.31 m)	7'-7"
Design Factors - Structural Members		3/1
- Critical Members (pins and hydraulics)		4/1

*The mounting space is based on the actual width of the crane. In addition to the 19" (48.3 cm), the crane must be spaced at least 2" (5.1 cm) from the truck cab. This

will give 2" (5.1 cm) of clearance between the cab and the rotating mast based on a 47" (119.4 cm) cab height.

PERFORMANCE CHARACTERISTICS

Rotation - 340° (5.93 Rad.)	30 Seconds
Main Boom Elevation - -45° to +75° (-0.79 Rad. to +1.31 Rad.)	22 Seconds
Secondary Boom Elevation - 140° (2.44 Rad.)	22 Seconds

LIFTING CAPACITY (from centerline of rotation)

(1.52 m) 5'-0"	(544 kg.)	1,200 lbs.
(2.44 m) 8'-0"	(340 kg.)	750 lbs.
(2.74 m) 9'-0"	(295 kg.)	650 lbs.
(3.25 m) 10'-8"	(249 kg.)	550 lbs.
(3.66 m) 12'-0"	(227 kg.)	500 lbs.
(4.27 m) 14'-0"	(181 kg.)	400 lbs.

CYLINDERS

	<u>Bore</u>	<u>Stroke</u>
Main	(7.6 cm) 3"	(45.7 cm) 18"
Secondary	(7.6 cm) 3"	(45.7 cm) 18"

POWER SOURCE

Power is supplied to the electric motor by a solenoid connected to the 12 VDC truck battery. The chassis must have a 4000 watt Delco Freedom battery (or comparable battery) connected in parallel to the chassis' standard heavy-duty battery. The chassis must also have a heavy-duty alternator (63 Amp. for GM vehicles and 60 Amp. for Ford vehicles).

CYLINDER HOLDING VALVES

The holding sides of all cylinders are equipped with integral-mounted counter-balance valves to prevent sudden cylinder collapse in case of hose or other hydraulic component failure. The counter-balance valve serves a dual function. First, it is a holding valve. Secondly, it is so constructed that it will control the lowering function and allow that motion to be feathered while under load.

HYDRAULIC SYSTEM

Open-centered, full-pressure system that requires 1-1/2 GPM (5.7 liters/min.) optimum oil flow at 1700 PSI (119.4 kgs/cm²). Three-spool, stack-type, electric, remote control valve bank. System includes a 4-gallon hydraulic oil reservoir, a 33-micron suction line filter and an electric, motor-driven hydraulic pump. All hydraulic lines from the valve bank to the individual functions are 1/4" SAE 100R2 hydraulic hose. The lines from the reservoir to the pump and from the valve bank to the reservoir are 1/2" SAE 100R4 hydraulic hose. The pressure line from the pump to the valve bank is 3/8" SAE 100R2 hydraulic hose.

ROTATION SYSTEM

Spur gear powered with a high-torque hydraulic motor through a pinion gear. Total gear reduction of 6:1.

CONTROLS

Remote control with a 25-foot control cable.

MINIMUM CHASSIS SPECIFICATIONS

Body Style		Conventional Cab
Wheel Base	(348 cm - 409 cm)	137" to 161"
Cab-to-Axle	(152 cm - 213 cm)	60" to 84"
Frame Section Modulus	(72.7 cm ³)	4.43 in ³
R B M	(2451 kg-m)	159,480 in-lbs.
Front Axle Rating	(1224 to 1814 kg)	2700 to 4000 lbs.
Rear Axle Rating	(2486 to 3402 kg)	5480 to 7500 lbs.
Gross Vehicle Weight Rating	(3583 to 4763 kg)	7900 to 10500 lbs.

In addition to these specifications, a heavy-duty battery and alternator are required. It is recommended that the vehicle be equipped with power steering and rear dual wheels.

IMT recommends for best total system performance that the upper limit of the specifications be adhered to.

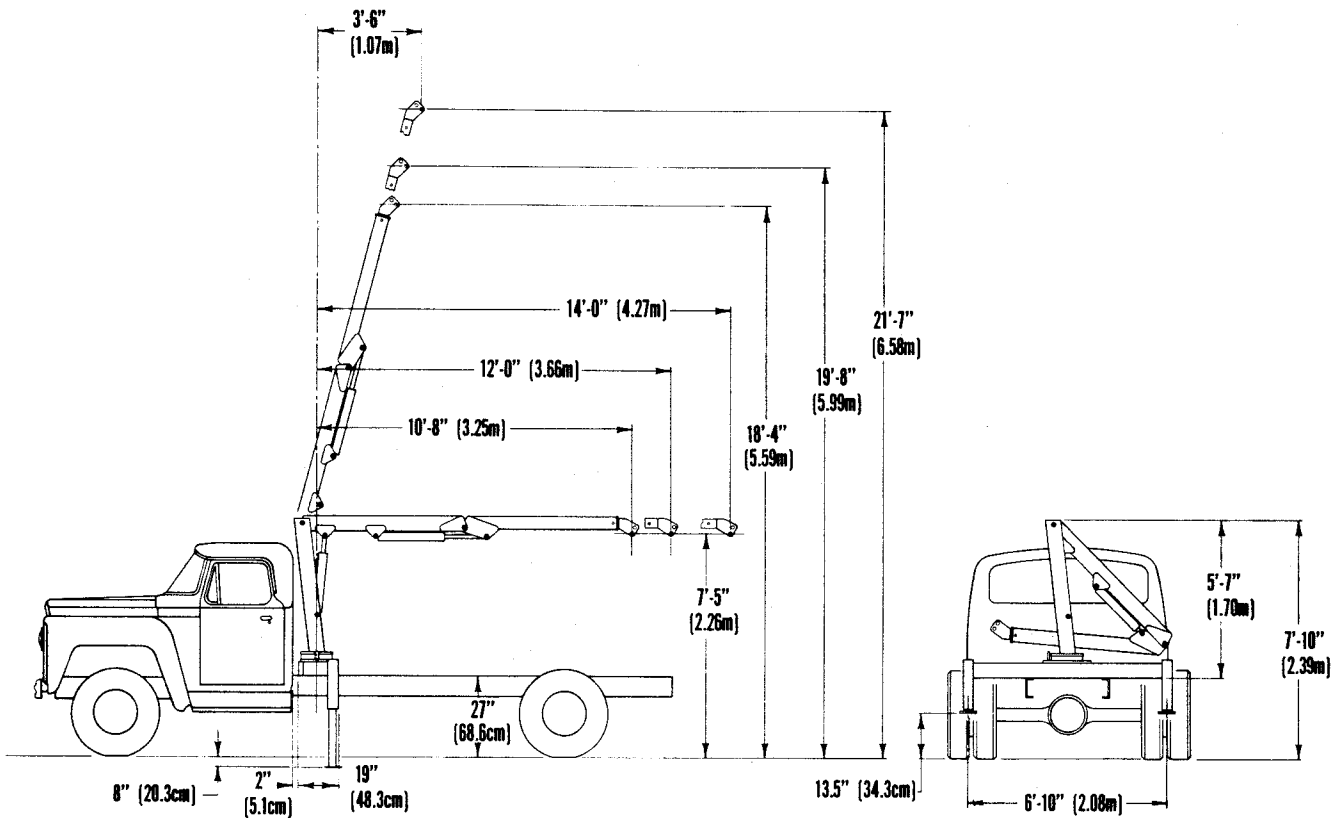
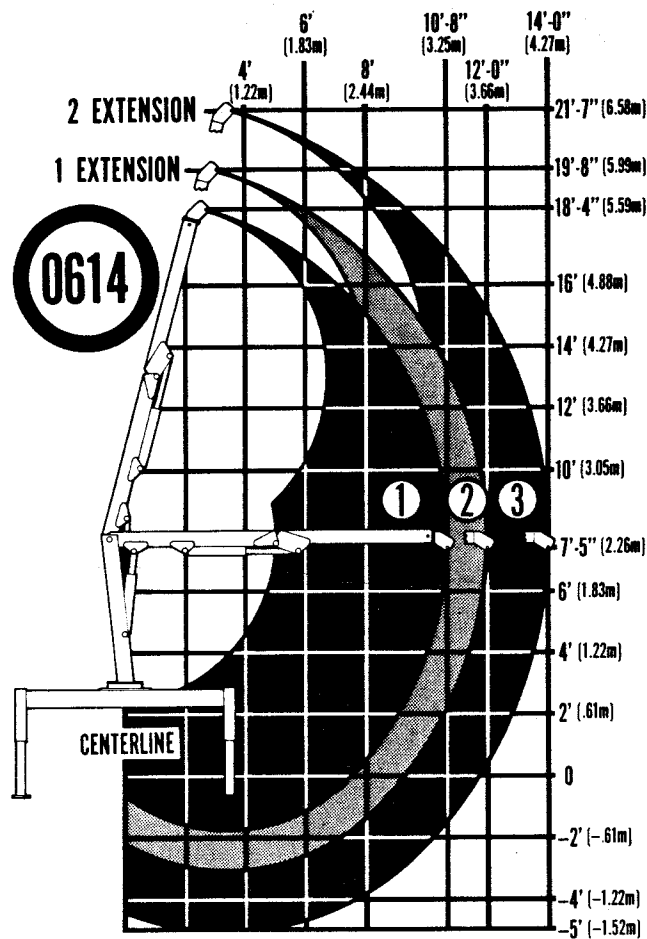

Figure A-1. Geometric Configuration



LIVE LOAD AT
BOOM
POSITION

CARGA MOVIL
EN LA POSICION
DE LA PLUMA

CHARGE
EN FONCTION
DE LA POSITION
DE LA FLECHE

When operating the unit, the load will be limited to those shown within their geometric ranges.

Cuando se opera la unidad, la carga limitada a aquellas que se ilustran de sus campos geometricos.

En fonctionnement les charges doivent etre limitees a celles figurees sur les aires geometriques.

1	SECONDARY BOOM PLUMA SECUNDARIA/FLECHE SECONDAIRE	550 lbs 249 kgs
2	1st EXTENSION 1ra EXTENSION/1ere EXTENSION	500 lbs 226 kgs
3	2nd EXTENSION 2da EXTENSION/2eme EXTENSION	400 lbs 181 kgs

Figure A-2. Capacity Chart

Section 2. CRANE DESCRIPTION

2-1. GENERAL

This section describes the major assemblies that are available with the IMT 0614 crane. Figure B-1 illustrates the location of the assemblies.

2-2. BASE

The base provides the means for mounting the crane on the truck chassis. It incorporates the 340° (5.93 Rad.) rotation mechanism and houses the outriggers. The outriggers provide a 6'-10" (2.08 m) span for stability and are raised and lowered manually.

2-3. MAST

The mast provides the necessary elevation for crane operation as well as a hinge point for the main boom.

2-4. MAIN BOOM

The main boom will swing through a full 120° (2.09 Rad.) from -45° to $+75^{\circ}$ (-0.78 Rad. to +1.31 Rad.). It is raised and lowered through the use of a single double-acting hydraulic cylinder.

2-5. SECONDARY BOOM

The secondary boom will swing through a full 140° (2.44 Rad.). It is raised through the use of a double-acting hydraulic cylinder.

2-6. EXTENSION BOOM

The extension boom will increase the operating range of the crane from 10'-8" (3.3 m) to 14'-0" (4.3 m). The extension is operated manually.

2-7. CONTROLS

The crane is operated from a remote-control unit with a 25-foot (7.6 m) cable.

2-8. HYDRAULIC KIT

The crane hydraulics consist of double-braided pressure hoses and return hoses, filter, control valve bank, pump and motor and all necessary hydraulic fittings.

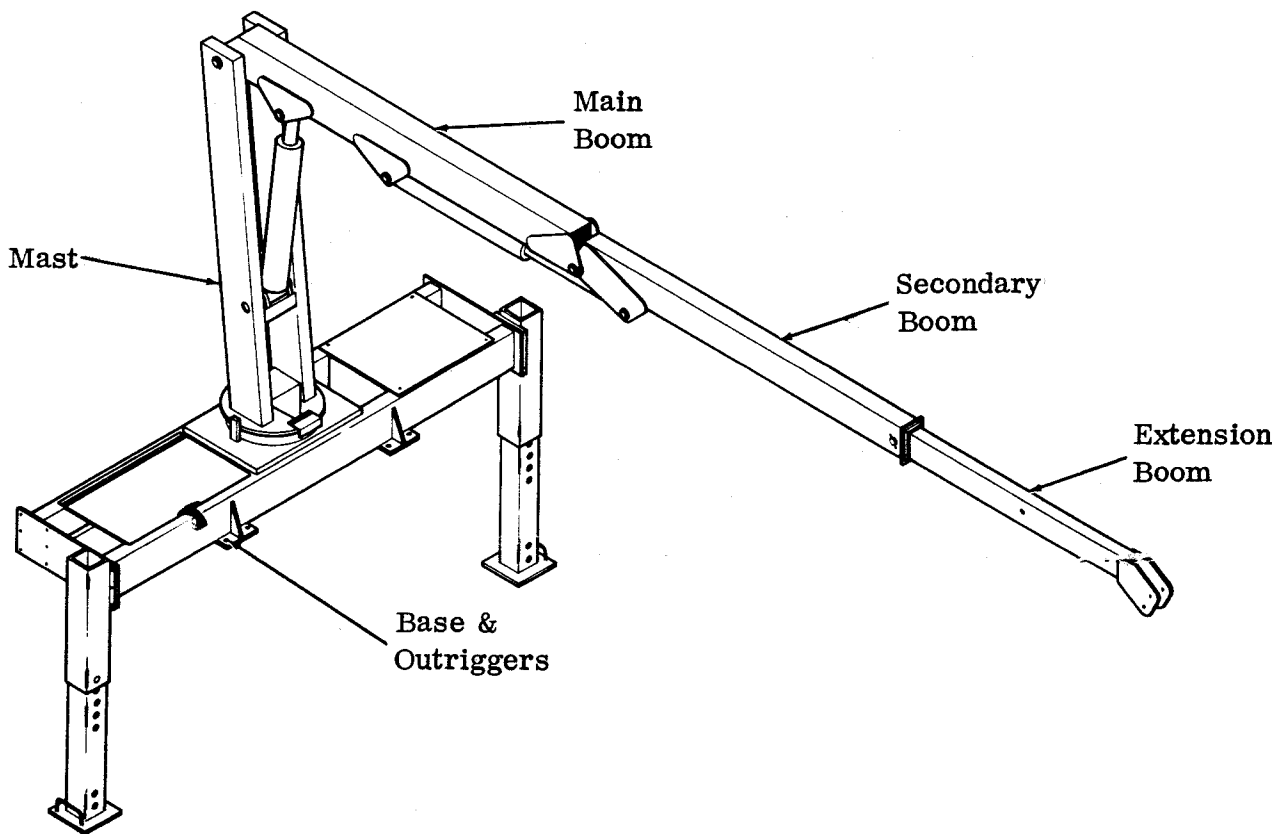

Figure B-1. 0614 Crane Group

Section 3. INSTALLATION

3-1. GENERAL

This section contains specific instructions for the installation of your crane.

To install the crane on the chassis:

1. Inspect the carrier vehicle to make certain it complies with the minimum chassis specifications shown in Table C-1.
2. Chassis frame must be clear of all obstructions where the crane will rest on the frame - about 21" (53.4 cm). Space will be available later for installation of gas tanks, etc. after the crane is installed.

NOTE

The actual distance will be determined by the height of the truck cab. In order to provide clearance for an angled mast, the higher the cab, the greater the mounting space required.

3. Use a lifting device capable of lifting the weight of the crane - 950 lbs. (431 kg.). Attach the lifting device to the lift bracket welded to the top of the main boom. Lift the crane, move the chassis into position under the crane and lower the crane onto the chassis in the desired position. Allow sufficient room between the crane and cab for mast rotation - at least 2" (5.1 cm). Check for front to rear alignment.
4. Install the tie rods, clamping plates and nuts to secure the crane. Torque to 60 ft. lbs. (8.3 kg-m).

TABLE C-1. MINIMUM CHASSIS SPECIFICATIONS

Wheelbase	(348 cm - 409 cm) 137" to 161"
Cab-to-Axle	(152 cm - 213 cm) 60" to 84"
Frame Section Modulus	(72.7 cm ³) 4.43 in ³
R B M.	(2,451 kg-m) 159,480 in-lbs.
Front Axle Rating	(1224 to 1814 kg) 2700 to 4000 lbs.
Rear Axle Rating	(2486 to 3402 kg) 5480 to 7500 lbs.

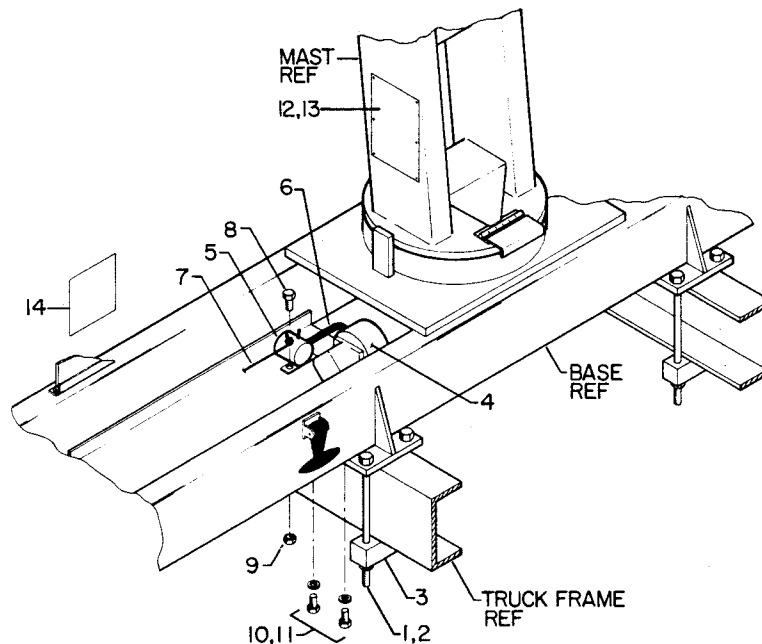

1. BOLT; 1/2-13 x 10-1/2" lg. hex hd.
2. NUT; 1/2-13 self-locking
3. PLATE, clamping

Figure C-1. Crane Installation

Section 4. PARTS LIST

4-1. GENERAL

This section contains the exploded parts drawings with the accompanying parts lists for the assemblies used on this crane. These drawings are intended to be used in conjunction with the instructions contained in the REPAIR section in Volume 1. For optional equipment such as winches and remote controls, refer to the appropriate service manual.

WARNING

Do not attempt to repair any component without reading the information contained in the REPAIR section in Volume 1. Pay particular attention to the WARNING's and CAUTION's contained in that section. Failure to comply with these instructions may result in damage to equipment, an injury or even death.

4-2. CRANE IDENTIFICATION

Every crane has an identification placard (Figure D-1) attached to the mast. When ordering parts, communicating warranty information or referring to the unit in correspondence, always include the assigned serial and model numbers. All inquiries should be addressed to Iowa Mold Tooling Co., Inc.; 500 Highway 18 West; Garner, Iowa 50438 or telephone (515) 923-3711.

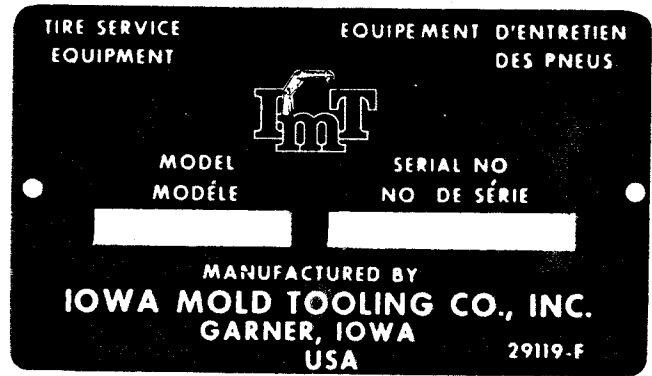

Figure D-1. Serial Number Placard

4-3. CYLINDER IDENTIFICATION

The crane has a cylinder identification placard (Figure D-2) attached to the mast. To ensure proper replacement parts are received, it is necessary to specify a complete number/letter sequence for any part request. Part numbers may be cross checked by comparing the stamped identification of the cylinder case (Figure D-3) against the information stamped on the placard. You must use the part number stamped on the cylinder case when ordering parts.

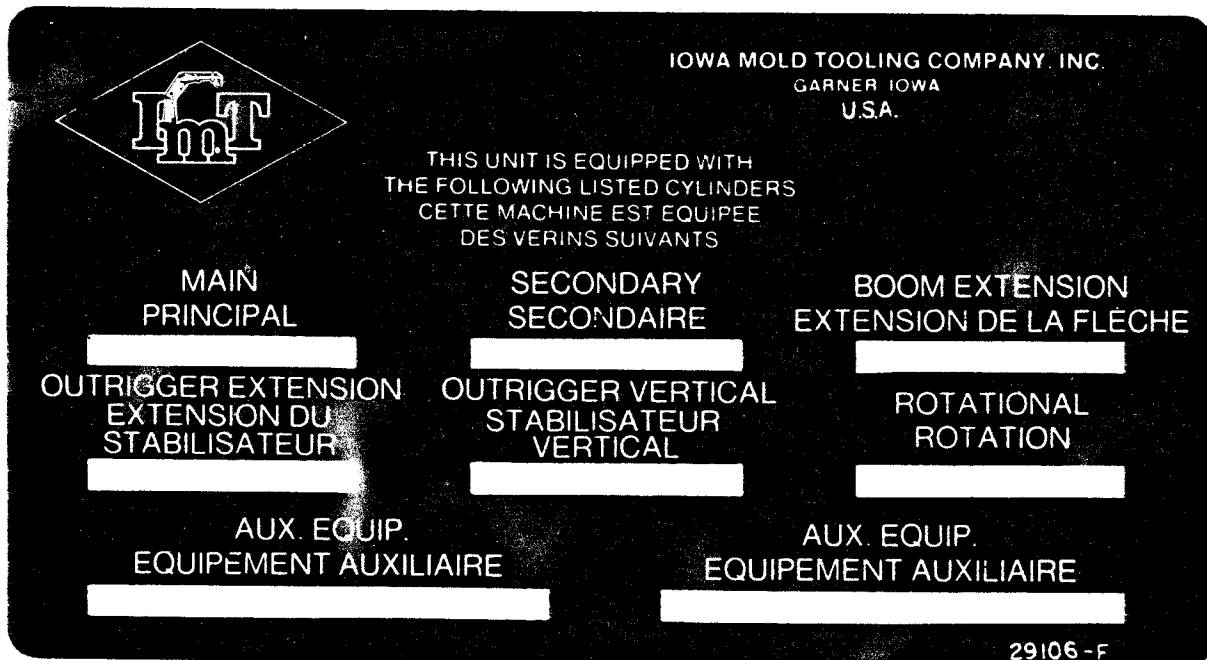

Figure D-2. Cylinder Identification Placard

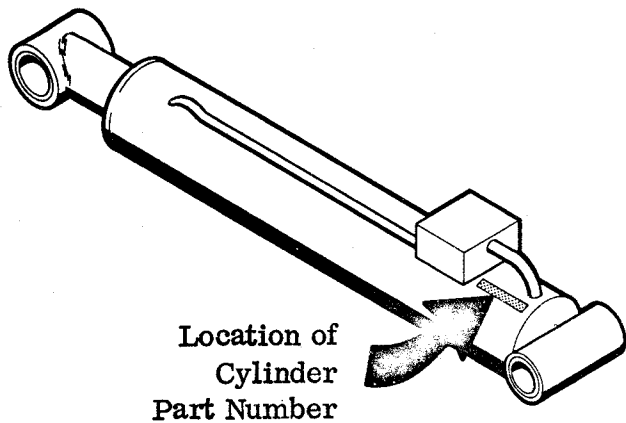

Figure D-3. Cylinder Part Number Location

4-4. WELDMENT IDENTIFICATION

Each of the major weldments - base, mast, main boom, secondary boom, extension boom(s) and outrigger weldments - bear a stamped part number. Any time a major weldment is replaced, you must specify the complete part number as stamped on the weldment. The locations of the part numbers are shown in Figure D-4.

4-5. ORDERING REPAIR PARTS

When ordering replacement parts:

1. Give the model number of the unit.
2. Give the serial number of the unit.
3. Specify the complete part number. When ordering cylinder parts or one of the main weldments, always give the stamped part number.
4. Give a complete description of the part.
5. Specify the quantity required.

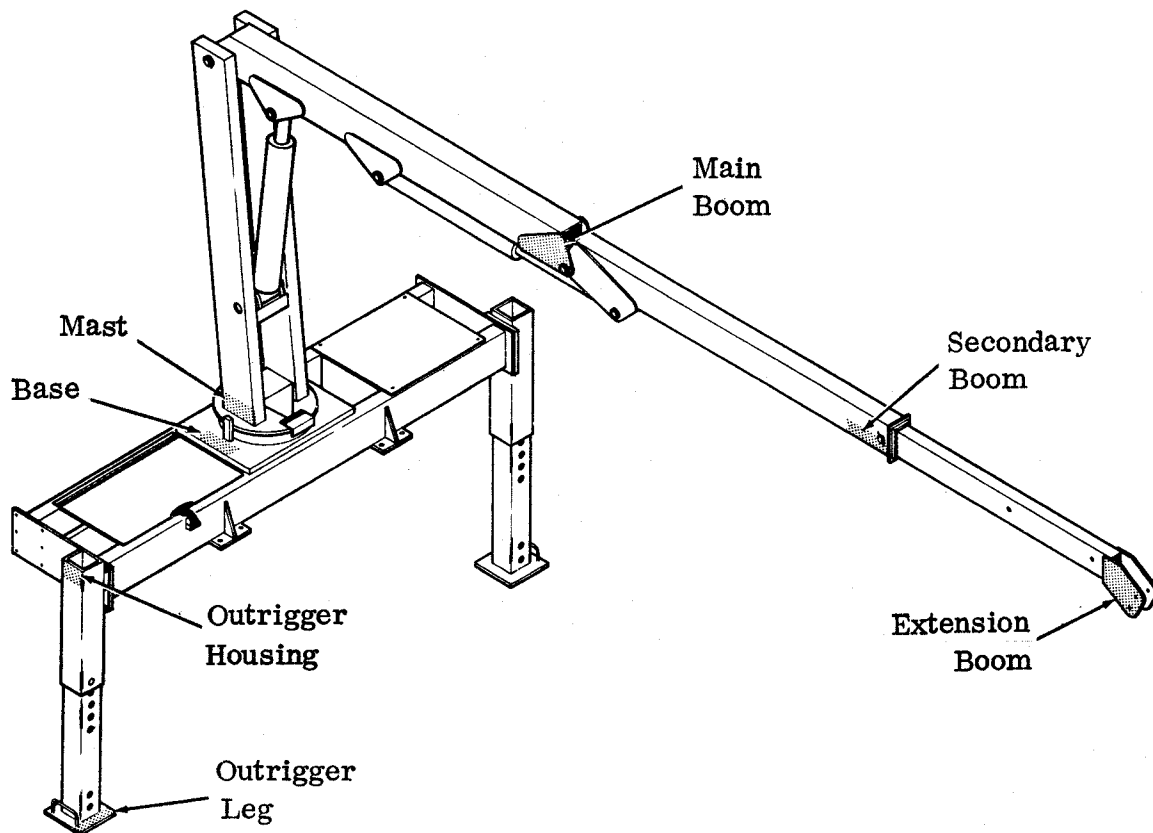
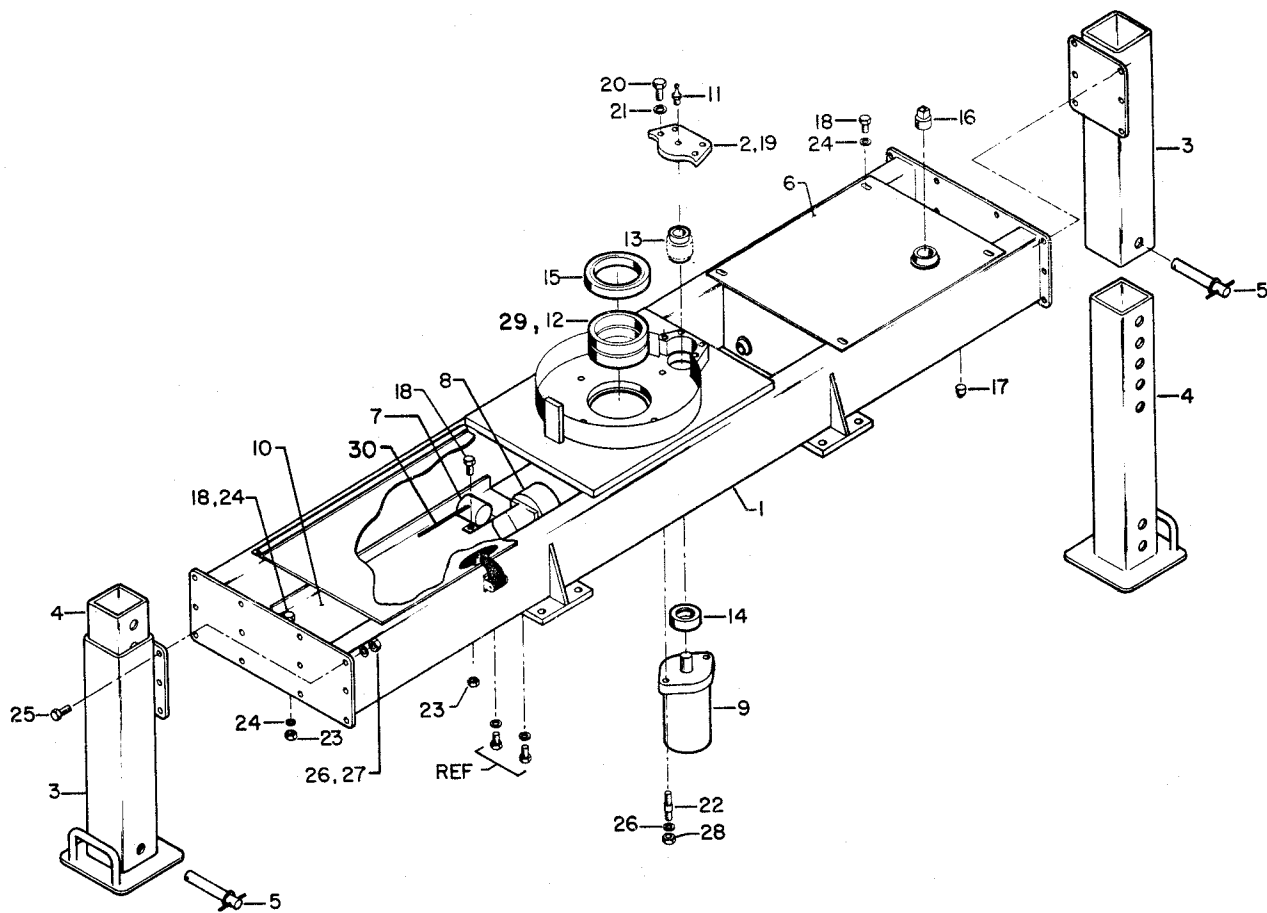
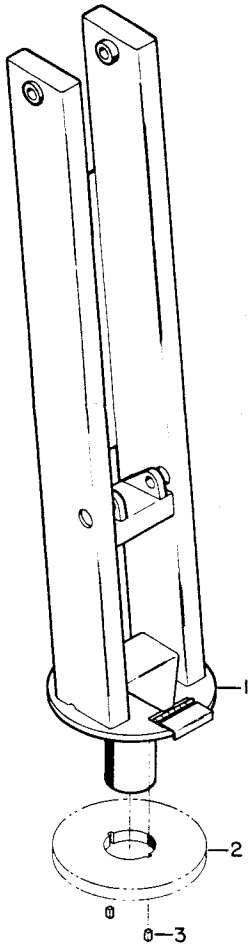

Figure D-4. Weldment Part Number Location



Item No.	Part No.	Description	Qty	Item No.	Part No.	Description	Qty
1.	52703802	BASE	1	16.	60106461	PLUG, vent; 1-1/4" npt	1
2.	60106463	PLATE, pinion support	1	17.	73052001	PLUG, magnetic; 3/4"	1
3.	52703811	HOUSING, outrigger	2	18.	72060004	SCREW; 1/4-20 x 1" hex hd.	10
4.	52703810	LEG, outrigger	2	19.	60020184	BUSHING (part of item 2)	Ref.
5.	71731361	PIN, outrigger	2	20.	72060092	SCREW; 1/2-13 x 1-1/4" hex hd.	4
6.	52703807	RESERVOIR	1	21.	72063053	WASHER, lock; 1/2"	4
7.	77041003	SOLENOID; 12 VDC	1	22.	60106032	STUD, hydraulic brake	2
8.	70073616	PUMP	Ref.	23.	72062104	NUT, lock; 1/4-20	6
9.	73051378	MOTOR	Ref.	24.	72063001	WASHER, wrt.; 1/4"	14
10.	60106460	TRAY	1	25.	72060046	SCREW; 3/8-16 x 1" hex hd.	12
11.	72053508	ZERK; 1/8" npt	1	26.	72063003	WASHER, wrt.; 3/8"	12
12.	60020183	BUSHING	1	27.	72062103	NUT, lock; 3/8-16	12
13.	71056267	GEAR, drive	1	28.	72062080	NUT, lock; 1/2-13	2
14.	60020179	BUSHING	1	29.	70055137	BEARING, cone	1
15.	70055136	BEARING, cup	1	30.	51701214	WIRE, ground; 52"	1

Figure D-5. Base and Outrigger (Part Number 41703791)



Item No.	Part No.	Description	Qty
1.	52703803	MAST	1
2.	71056266	GEAR, rotation	1
3.	60106429	KEY	2
4.	60106437	WASHER, hold-down	1
5.	51703813	BEARING Assembly	Ref.
6.	60020183	BUSHING	Ref.
7.	72060093	SCREW; 1/2-13 x 1-1/2" hex hd.	2
8.	72063053	WASHER, lock; 1/2"	2
9.	73073101	EXTENSION, grease; 18"	1
10.	72053508	ZERK; 1/8" npt	1
11.	72063004	WASHER, wrt.; 7/16"	1
12.	72053301	COUPLING; 1/8" npt	1

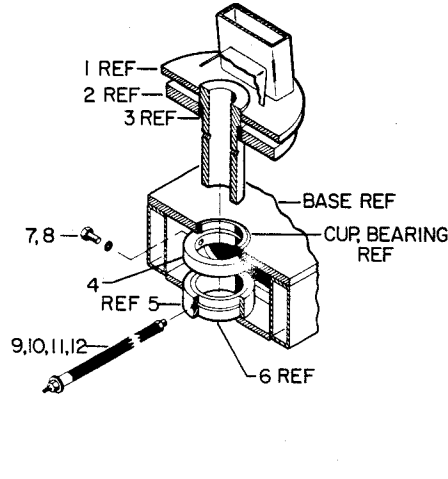

Figure D-6. Mast (Part Number 41703792)

Item No.	Part No.	Description	Qty
1.	52703804	BOOM, main	1
2.	3B129082	CYLINDER, main	1
3.	60106419	PIN, main/mast	1
4.	60101906	PIN, cyl./main & cyl./ mast	2
5.	72053508	ZERK; 1/8" npt	1
6.	72053507	ZERK; 1/4-28	2
7.	72063034	BUSHING, machy.; 1" x 10 ga.	6
8.	72066080	RING, retaining; 1"	6

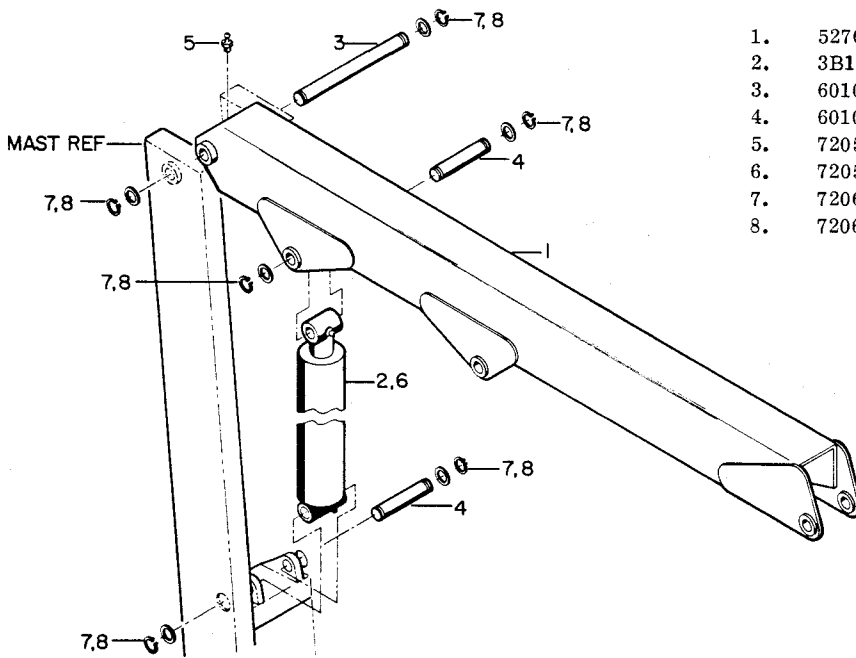
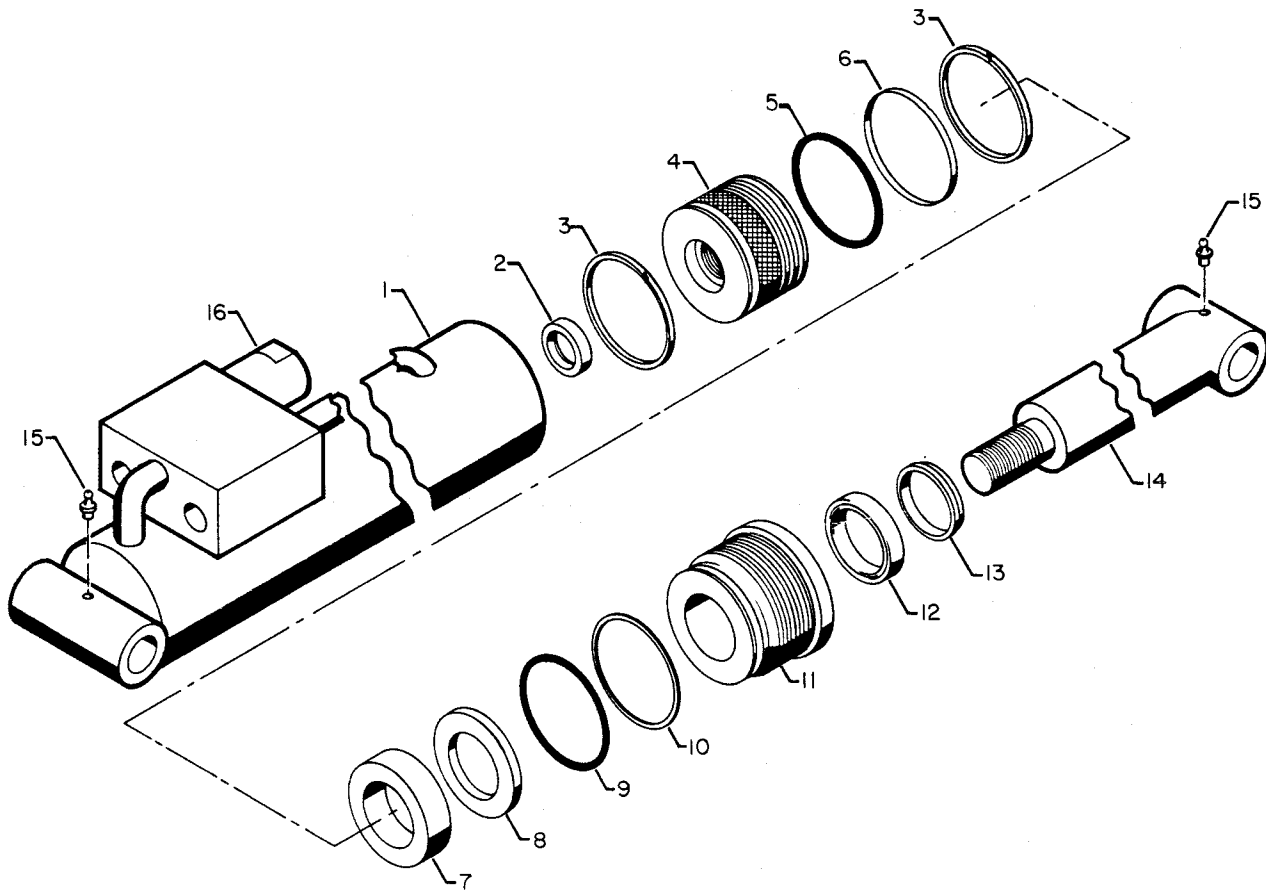

Figure D-7. Main Boom (Part Number 41703793)



Item No.	Part No.	Description	Qty	Item No.	Part No.	Description	Qty
1.	4B129081	CASE, cylinder	1	9.	7Q072334	*O-RING	1
2.	7T61N106	*SEAL, lock ring	1	10.	7Q10P334	*RING, back-up	1
3.	7T65I030	*RING, piston	2	11.	6H030017	HEAD	1
4.	6I030106	PISTON	1	12.	7R546017	*SEAL, rod	1
5.	7Q072145	*O-RING	1	13.	7R14P017	*WIPER, rod	1
6.	7T66P030	*SEAL, piston	1	14.	4G129081	ROD	1
7.	6C075017	TUBE, stop	1	15.	72053507	ZERK, grease; 1/4-28	2
8.	6A025017	*RING, wafer lock	1	16.	73054242	VALVE, counter balance	1

*Part of seal kit (Part Number 9C121417)

Figure D-8. Main and Secondary Cylinder (Part Number 3B129082)

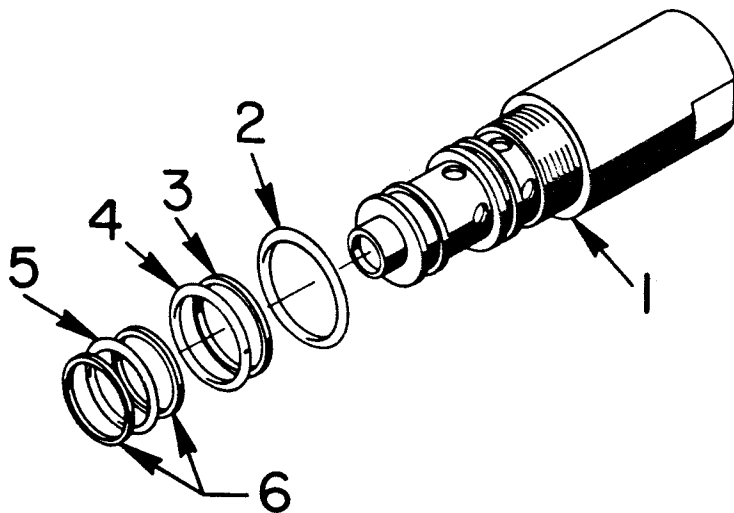

Item No.	Part No.	Description	Qty
1.	--	BODY, valve (not a replacement part)	1
2.	7Q072215	O-RING	1
3.	7Q10P021	RING, back-up	1
4.	7Q072021	O-RING	1
5.	7Q072020	O-RING	1
6.	7Q10P020	RING, back-up	2

Figure D-9. Counter-Balance Holding Valve (Part Number 73054242)

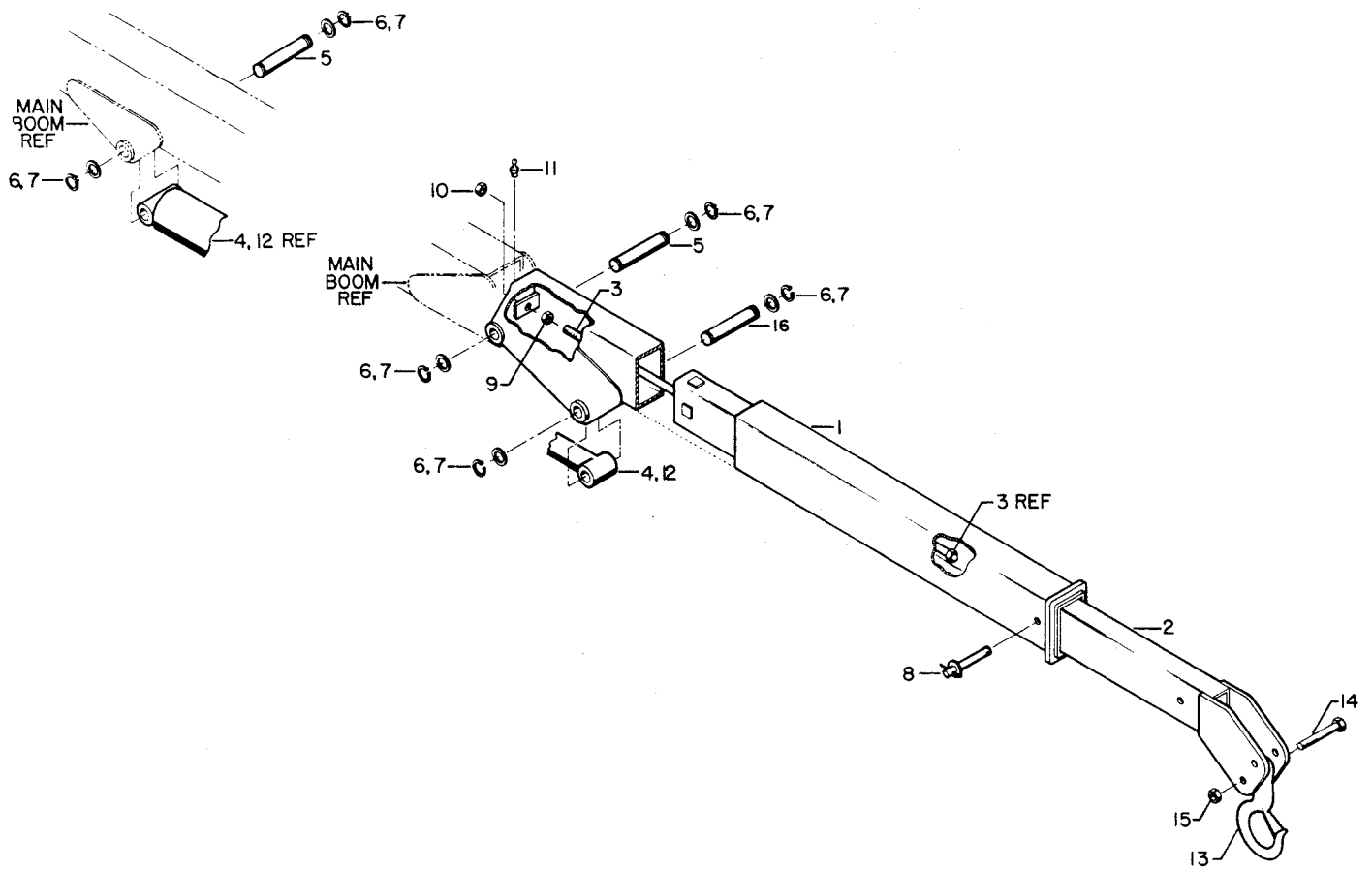

0614 Secondary and Extension Boom Assembly (Part Number 41703794)

Item No.	Part No.	Description	Qty	Item No.	Part No.	Description	Qty
1.	52703805	BOOM, secondary	1	9.	72062004	NUT; 1/2-13	1
2.	52703806	BOOM, extension	1	10.	72062080	NUT, lock; 1/2-13	1
3.	52703812	ROD, stop	1	11.	72053508	ZERK; 1/8" npt	1
4.	3B129082	CYLINDER, hydraulic	1	12.	72053507	ZERK; 1/4-28	2
5.	60101906	PIN	2	13.	70731406	HOOK, swivel	1
6.	72063034	BUSHING, machy.; 1" x 10 ga.	6	14.	72060178	SCREW; 5/8-11 x 4" hex hd. gr. 8	1
7.	72066080	RING, retaining; 1"	6	15.	72062091	NUT, lock; 5/8-11	1
8.	71731405	PIN, quick-release	1	16.	60104028	PIN	1

Figure D-10. Secondary and Extension Boom (Part Number 41703794)

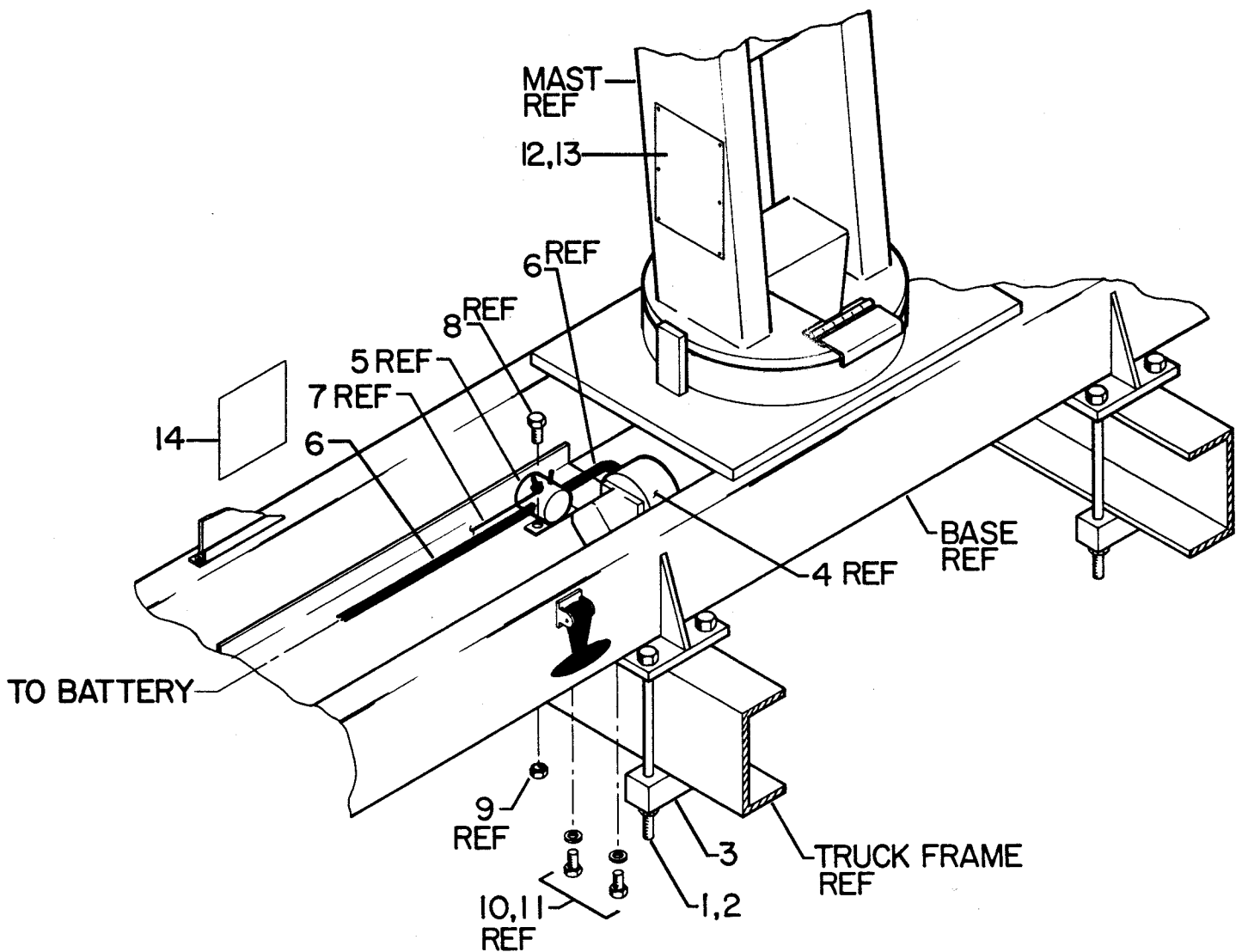

Item No.	Part No.	Description	Qty	Item No.	Part No.	Description	Qty
1.	72060112	BOLT; 1/2-13 x 10-1/2" hex hd.	8	9.	72062104	NUT, lock; 1/4-20	Ref.
2.	72062080	NUT, lock; 1/2-13	8	10.	72060046	SCREW; 3/8-16 x 1" hex hd.	Ref.
3.	60106466	PLATE, clamp	4	11.	72063051	WASHER, lock; 3/8"	Ref.
4.	70073616	PUMP & MOTOR	Ref.	12.	--	PLACARD, capacity	2
5.	77041003	SOLENOID; 12 VDC	Ref.	13.	72066340	RIVET, pop; 1/8"	12
6.	51701233	CABLE, battery; 240"	1	14.	--	DECAL, electrical diagram	1
7.	51701214	WIRE, ground; 52"	Ref.	15.	70392108	DECAL, "SUCTION LINE"	1
8.	72060004	SCREW; 1/4-20 x 1" hex hd.	Ref.	16.	70392109	DECAL, "RETURN LINE"	1

Figure D-11. Installation Kit (Part Number 93703797)

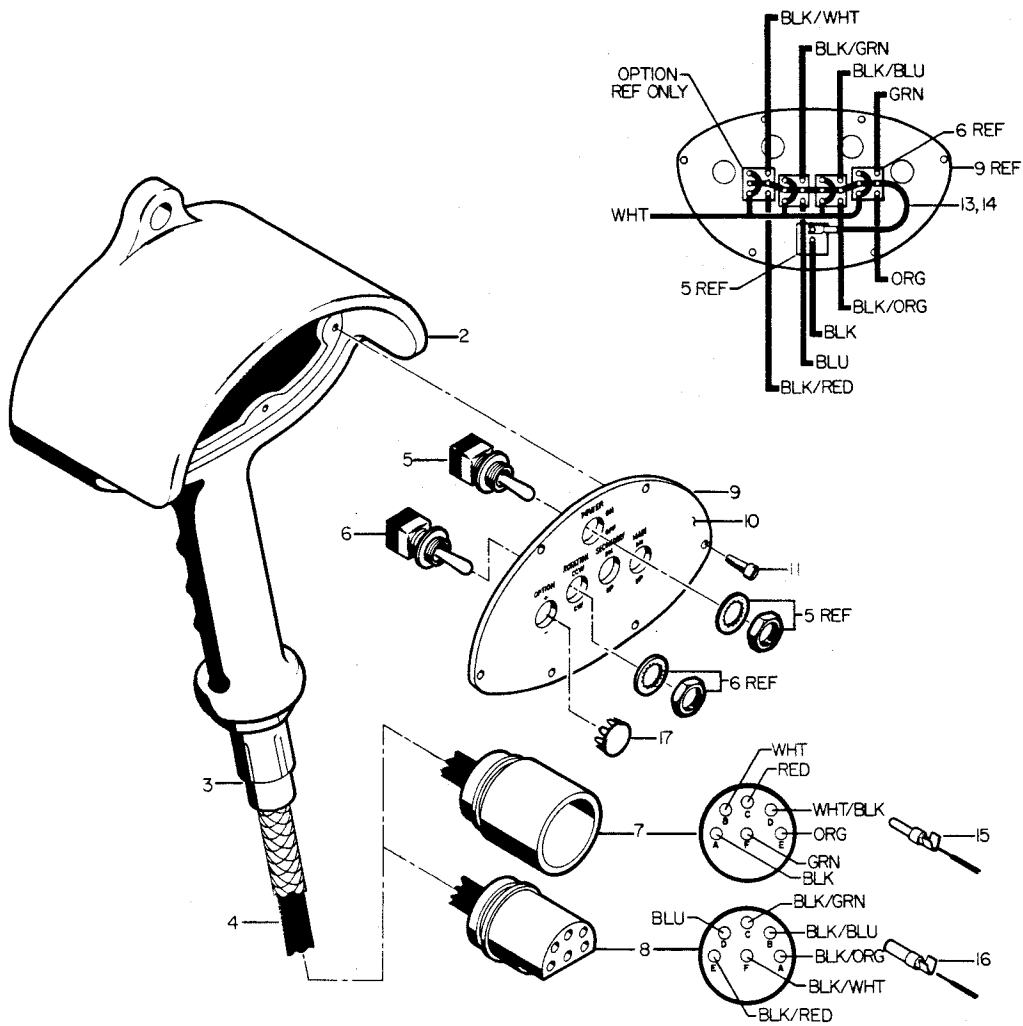

Item No.	Part No.	Description	Qty	Item No.	Part No.	Description	Qty
1.	51704111	HANDLE & CABLE (includes items 2 thru 17)	1	9.	60025146	PLATE	1
2.	60025171	HANDLE	1	10.	70029275	PLACARD, control	1
3.	77044096	GRIP, cord	1	11.	72061003	SCREW, self-tap; #6 x 1/2"	6
4.	60045046	CABLE, 18 ga.; 12-wire x 300 in.	1	12.	71392096	TAG, caution (not shown)	1
5.	77041004	SWITCH, toggle, single-throw	1	13.	60045053	WIRE; 18 ga. x 7" lg.	1
6.	77041169	SWITCH, toggle, double-throw	3	14.	77040051	TERMINAL	1
7.	77044205	RECEPTACLE	1	15.	77044206	PIN, contact	6
8.	77044204	PLUG	1	16.	77044207	SOCKET, contact	6
				17.	72661125	BUTTON, snap	1

Figure D-12. Remote Control Kit - Sheet 1 of 2 (Part Number 90703798)

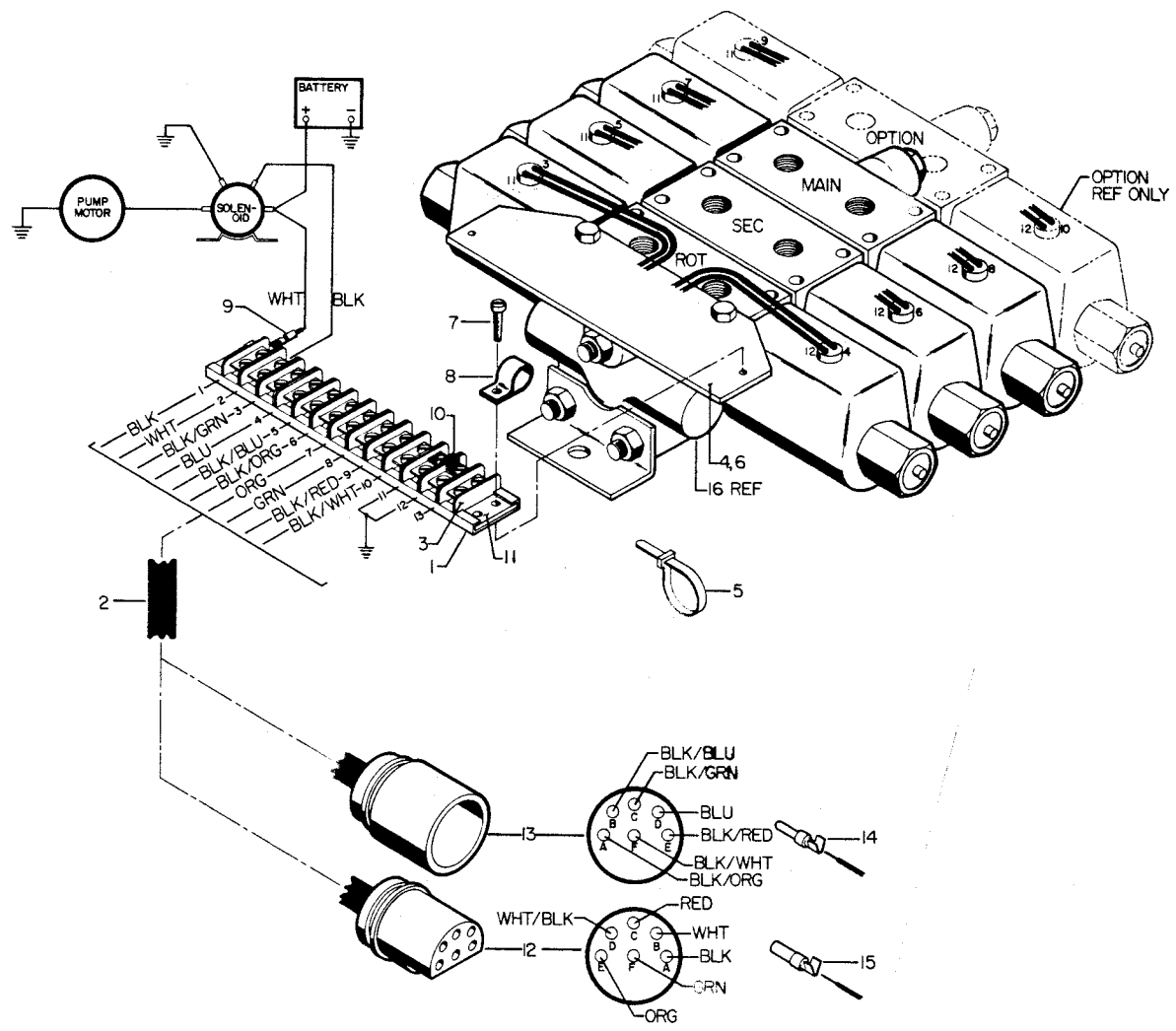

Item No.	Part No.	Description	Qty	Item No.	Part No.	Description	Qty
1.	60045045	BOARD, terminal	1	9.	77040051	TERMINAL	28
2.	60045059	CABLE, 18 ga.; 12-wire x 36" lg.	1	10.	77040130	BAR, jumper	1
3.	60045060	STRIP, terminal	1	11.	77044111	STOP, end	2
4.	60105825	BOARD, terminal strip mounting	1	12.	77044204	PLUG	1
5.	70034060	TIE, plastic	4	13.	77044205	RECEPTACLE	1
6.	72060002	SCREW; 1/4-20 x 3/4" hex hd.	2	14.	77044206	PIN, contact	6
7.	72061008	SCREW, self-tap; #8 x 3/4"	2	15.	77044207	SOCKET, contact	6
8.	72066525	CLAMP; 3/4"	1	16.	--	VALVE BANK	Ref.

Figure D-13. Remote Control Kit - Sheet 2 of 2 (Part Number 90703798)

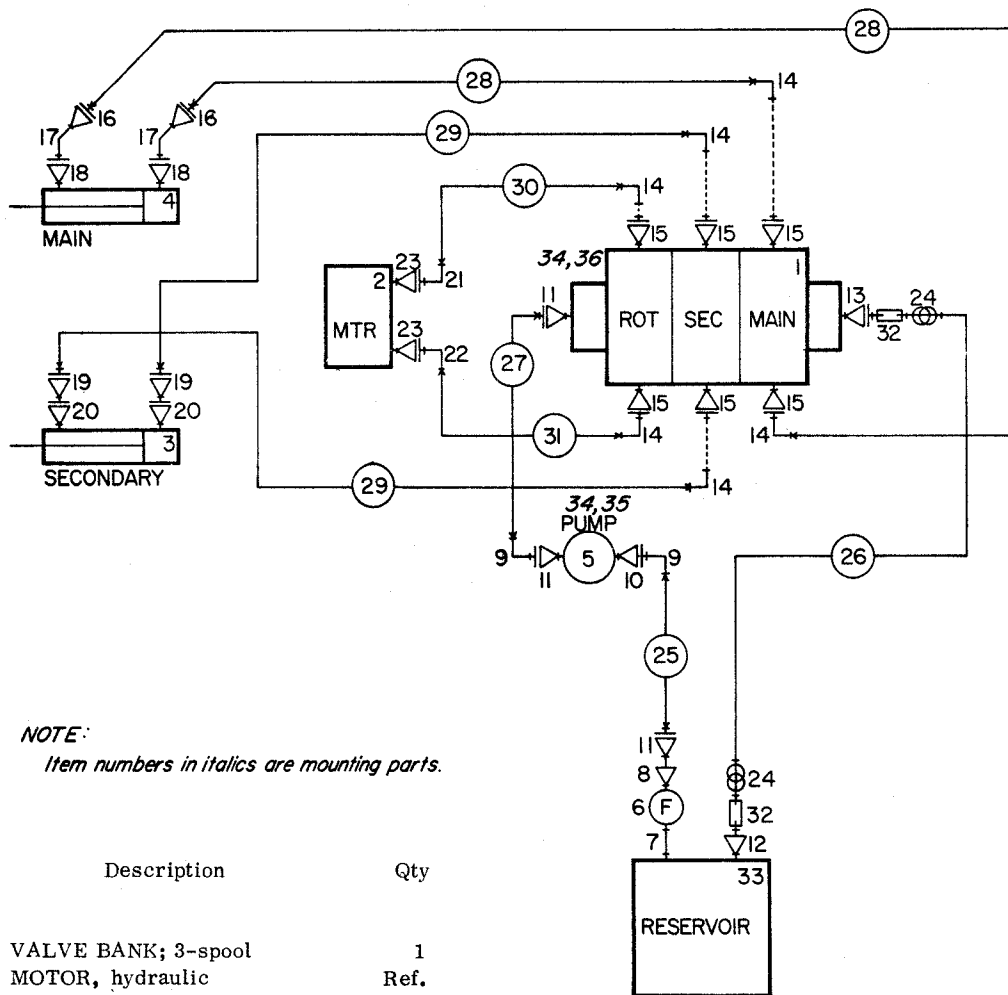

NOTE:
Item numbers in italics are mounting parts.

Item No.	Part No.	Description	Qty
1.	73073039	VALVE BANK; 3-spool	1
2.	--	MOTOR, hydraulic	Ref.
3.	--	CYLINDER, secondary	Ref.
4.	--	CYLINDER, main	Ref.
5.	70073616	PUMP	1
6.	73052012	FILTER	1
	73052014	ELEMENT, filter	Ref.
7.	72053141	NIPPLE, close; 3/4" npt	1
8.	72531832	BUSHING, reducer; 3/4" npt(m) x 3/8" npt(f)	1
9.	72531132	ELBOW, street, 90°; 3/8" npt	2
10.	72053644	SWIVEL; 1/2" npt(m) x 3/8" npt(f)	1
11.	72053642	SWIVEL; 3/8" npt(m x f)	3
12.	72531833	BUSHING, reducer; 3/4" npt(m) x 1/2" npt(f)	1
13.	72532278	SWIVEL; 3/8" npt(m) x 1/2" npt(f)	1
14.	72532690	ELBOW, 90 swivel; 7/16-20 JIC(m) x 7/16-20 JIC(f)	6
15.	72532353	ADAPTER; 9/16-18 str. thd. (m) x 7/16-20 JIC(m)	6
16.	72053499	ADAPTER; 1/4" npt(m) x 7/16-20 JIC(m)	2
17.	72053533	ELBOW, street, 45°; 1/4" npt	2
18.	72053513	ADAPTER; 3/4" str. thd. (m) x 1/4" npt(f)	2
19.	72532665	ADAPTER; 7/16-20 JIC(m) x 3/4-16 JIC(f)	2
20.	72532358	ADAPTER; 3/4-16 str. thd. (m) x 3/4-16 JIC(m)	2
21.	72531412	ELBOW, 90°; 1/4" npt(m) x 7/16-20 JIC(m)	1
22.	72532512	ELBOW, extra-long 90°; 1/4" npt(m) x 7/16-20 JIC(m)	1

Item No.	Part No.	Description	Qty
23.	72532138	BUSHING, reducer; 3/8" npt(m) x 1/4" npt(f)	2
24.	72066061	CLAMP, hose; #6	2
25.	51704021	HOSE; 3/8" ID x 22" lg.	1
26.	60035624	HOSE; 1/2" ID x 42" lg.	1
27.	51703769	HOSE; 3/8" ID x 5-1/4" lg.	1
28.	51703770	HOSE; 1/4" ID x 60" lg.	2
29.	51703773	HOSE; 1/4" ID x 132" lg.	2
30.	51703772	HOSE; 1/4" ID x 26" lg.	1
31.	51703771	HOSE; 1/4" ID x 29" lg.	1
32.	72053457	NIPPLE, barbed; 1/2"	2
33.	--	RESERVOIR	Ref.
34.	72060046	SCREW; 3/8-16 x 1" hex hd.	4
35.	72063051	WASHER, lock; 3/8"	2
36.	72062103	NUT, lock; 3/8-16	2

Figure D-14. Hydraulic Kit (Part Number 91703799)

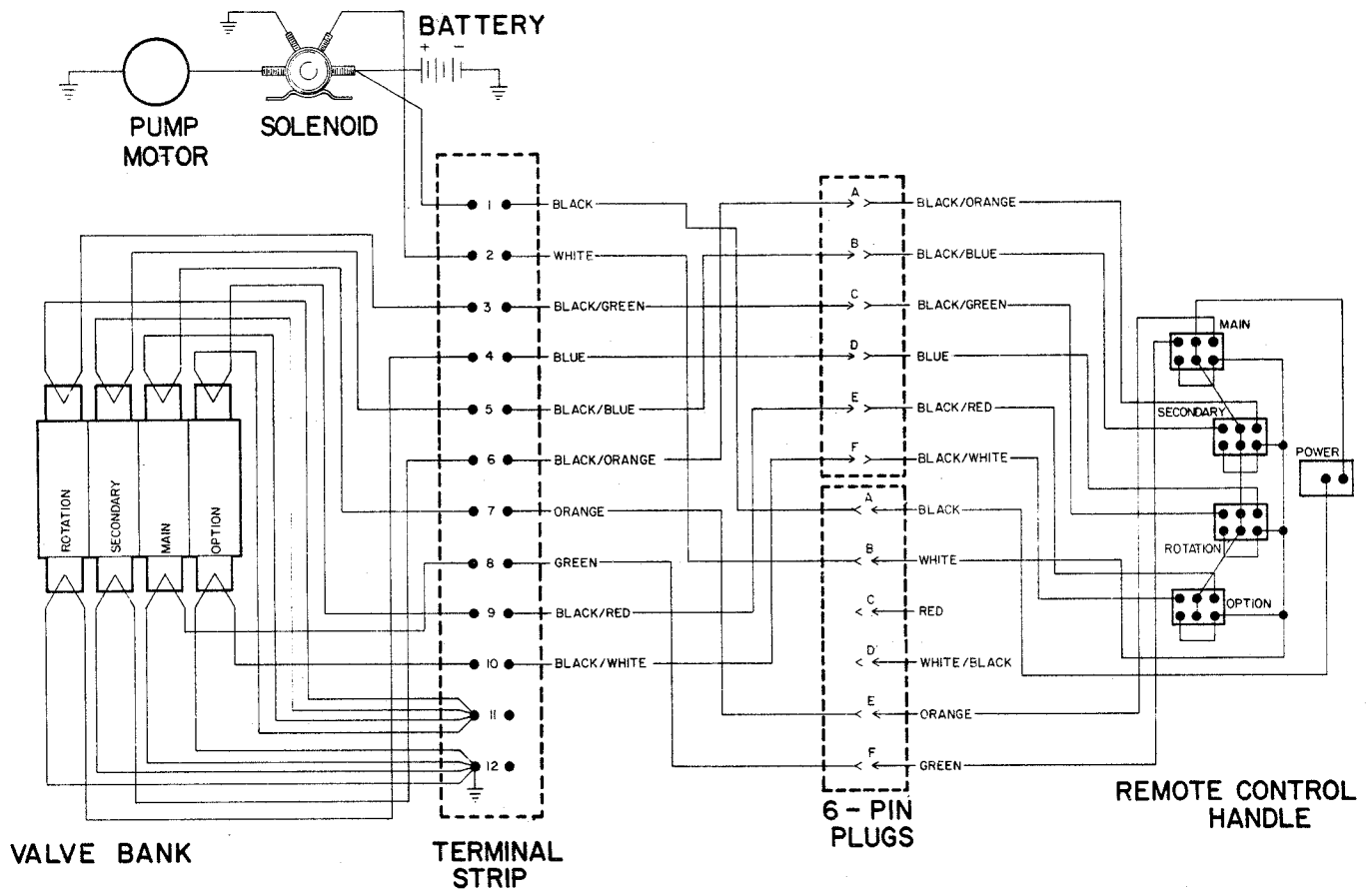

Figure D-15. Wiring Diagram

SPARE PARTS LIST

1-YEAR SUPPLY

Item No.	Part No.	Description	Qty
1.	77041003	SOLENOID; 12 VDC	1
2.	70073616	PUMP; 12 VDC	1
3.	73051228	MOTOR, hydraulic rotation	1
4.	60020184	BUSHING, drive gear, top	1
5.	71056267	GEAR, drive	1
6.	60020179	BUSHING, drive gear, bottom	1
7.	70055136	BEARING, crane rotation	1
8.	60020184	BUSHING, support plate	1
9.	71056266	GEAR, rotation	1
10.	51703813	BEARING, mast	1
11.	60020183	BUSHING, mast	1
12.	73054242	VALVE, counter balance	2
13.	77041004	SWITCH, toggle, POWER ON/OFF	1
14.	77041169	SWITCH, toggle, crane functions	1
15.	73073039	VALVE BANK; 3-spool	1
16.	73052014	ELEMENT, filter	4
17.	9C121417	SEAL KIT, cylinder	2

This spare parts list does not necessarily indicate that the items listed can be expected to fail in the course of a year. It is intended to provide the user with a stock of parts sufficient to keep the unit operating with no downtime waiting for parts. Obviously, there may be part failures not covered by this list.